

# Table of Contents

## SUPCO PART NUMBER INDEX ii-viii

HVAC	Page
AC Hard Starts	2 - 3
Relays	4 - 5
Capacitors	
Run Capacitors	6
Start Capacitors	7
Contactors	8 - 9
Surge Protection	10 - 11
Motor Protection	12
Timers	13 - 14
Cold Controls	15
Time Delays	16
Motors	17 - 19
HVAC Duct Boosters	19
Fan Blades	20 - 21
Pressure Switches	22 - 23
Driers	24 - 28
Cap Tubing	29 - 31
Belts	32
Heaters	33 - 34
Transformers	35
Sequencers	36
Thermostats	37 - 42
Furnace Igniters	43 - 49
Wall Thermostats	50 - 54
Thermostat Guards	55

## INSTALLATION

	Page
LI'L Popper	56
ECAP321	56
Anti-Vibration Pads	56
Hard start Ad	57

## REFRIGERATION

	Page
Refrigeration Relay, Overloads & Hard Starts	58 - 61
Valves & Fittings	62 - 65
Valve Tools	65
Condensate Drain Pans	66 - 67
Heaters	67

## TEST INSTRUMENTS

	Page
Vacuum & Pressure Gauges	68 - 69
Temperature, Humidity Testers & Thermometers	70 - 73
Temperature Alarms and Controls	74 - 76
Specialty Meters	77 - 80
Multimeters and Current Probes	81
Data Loggers	82 - 88
Chart Recorders	89 - 98

## TOOLS

	Page
Innovative Tools	99 - 102
Tools & Accessories	103- 106

## TERMINALS & CONNECTORS

Page  
107 - 110

## CHEMICALS

Page  
111 - 117

## TECHNICAL DATA

Page  
118 - 129



**Sealed Unit Parts Co., Inc.**

PO Box 21, 2230 Landmark Place  
Allenwood, NJ 08720 USA

Phone (732)223-6644 • Fax (732)223-1617  
www.supco.com • info@supco.com

# SUPCO Part Number Index

SUPCO PART NO.		SUPCO PART NO.		SU	
31	66	90384	5	A158	32
70	66	14265-001	87	A19 thru A99	32
75	66	24H10BAR	93	ADTA	75, 83
5011	14	24H150PSI	93	ADTA	89
5014	14	24H3.5BAR	93	ADTA	91
9063	4	24H35BAR	93	APP120	11
9064	4	24H500PSI	93	AT012 thru AT015	39
9065	4	24H50PSI	93	AT021	39
9066	4	30-220-OS	66	AT022	39
9067	4	30-OS	66	B101 thru B360	32
9068	4	30WM	66	B23 thru B99	32
9069	4	31-220	66	BC1 thru BC5	29
9070	4	31D10BAR	93	BC1-100 thru BC5-100	29
9071	4	31D150PSI	93	BJ10	105
10475	68, 69	31D3.5BAR	93	BJ10PLUS	105
11093	75	31D35BAR	93	BPV12	61
13495	75	31D500PSI	93	BPV14	61
14263	75	31D50PSI	93	BPV21	61
14265	75	31WM	66	BPV31	61
14753	87	50100B	14	BPV31D	61
14754	87	50103B	14	BPV34	61
19994	75	50150B	14	BPV36	61
19995	75	50153B	14	BPV38	61
20540	75	5PAK	29	BPV56	61
5-Apr	4	6H10BAR	93	BPV58	61
43004	53, 54	6H150PSI	93	BPV78	61
43005	53, 54	6H3.5BAR	93	BTG-54VL	55
43054	50, 54	6H35BAR	93	BTG-54VLW	55
43055	50, 54	6H500PSI	93	BTG-DB2	55
43057	51, 54	6H50PSI	93	BTG-DK	55
43058	51, 54	70056A	106	BTG-DO	55
43154	51, 54	70056B	106	BTG-EK	55
43168	51, 54	70-220	66	BTG-EM	55
43309	53, 54	70CSA	66	BTG-EO	55
43320	53, 54	70CSA220	66	BTG-K	55
43355	52, 54	75-220	66	BTG-KM	55
43359	53, 54	7D10BAR	93	BTG-KWM	55
43503	52, 54	7D150PSI	93	BTG-O	55
43558	52, 54	7D3.5BAR	93	BTG-RB2	55
43658	51, 54	7D35BAR	93	BTG-RK	55
43658	52, 54	7D500PSI	93	BTG-RM	55
43665	52, 54	7D50PSI	93	BTG-RO	55
43758	52, 54	9900H	117	BTG-RWM	55
43855	50, 54	9904H	117	BTG-UK2	55
90290	5	9904K	117	BTG-UM	55
90291	5	9906H	117	BTG-UO2	55
90292	5	9906K	117	BTG-UV2	55
90293	5	9915K	117	BTG-UWM	55
90294	5	A100	32	BX35 thru BX300	32
90295	5	A105	32	CABLE10H	83
90340	4	A110	32	CABLE10H	87
90341	4	A112	32	CABLE10H	89
90342	4	A116	32	CABLE10H	91
90370	5	A120	32	CABLE10H	96
90372	5	A124	32	CABLE10T	87
90374	5	A128	32	CABLE10T	91
90380	5	A136	32	CABLE15	91
90382	5	A144	32	CABLE15	94

# SUPCO Part Number Index

SUPCO PART NO.		SUPCO PART NO.		SU	
CABLE15	96	CR87B	95	CSLD14S4 THRU CSLD14S7	24
CABLE25	91	CR87B	92	CSLD14S9	24
CABLE25	94	CR87B220	92	CTC3	29
CABLE25	96	CR87B220C	92	CTC3	80
CABLE33H	83	CR87BC	92	CTP1	104
CABLE6	91	CR87E	93	DA76210	102
CABLE6	94	CR87E	95	DA76440	100
CABLE6	96	CR87E220	93	DA76450	100
CC6	96	CR87HT	92	DA86400	99
CD101	14	CR87HT	95	DA86420	99
CD104	14	CR87HT220	92	DAVM+	78
CD15+5X370 thru CD60+10X370	6	CR87HT22C	92	DB10	19
CD20+5X370R thru CD80+7.5X370R	6	CR87HTC	92	DB12	19
CD20+5X440 thru CD60+5X440	6	CR87J	92	DB6	19
CD20+5X440R thru CD80+10X440R	6	CR87J	95	DB6-220	19
CFM	78	CR87J220	92	DB8	19
CH101	34	CR87JC	92	DDM55	80
CH101-3	34	CR87P	93	DDT2	71, 72
CH102	34	CR87P	95	DH500	33
CH103	34	CR87P220	93	DH500-3	33
CH104	34	CR87PA	93	DH500FC	33
CH1042	34	CR87PB	93	DH501	33
CH105	34	CR87PB220	93	DH502-4	33
CH1053	34	CR87V	93	DH506	33
CH1202	34	CR87V	95	DH507	33
CH135	34	CR87V220	93	DH520	33
CH197	34	CR8J7220C	92	DH534	33
CL50	79	CRPEN	91	DH560	33
CMM	78	CRPEN	94	DHS55	80
CO1000	79	CRPEN	96	DHS55	104
CP801	66, 129	CRPENB	89	DLTP6	87
CP802	66, 129	CRPENB	91	DM10T	81
CP802-240	66, 129	CRPENB	94	DP201202	8, 9
CP804	66, 129	CRPENB	96	DP202402	8, 9
CP804-240	66, 129	CRPENR	89	DP20242	8, 9
CP804HD	66, 129	CRPENR	91	DP251201	8, 9
CP804HD-240	66, 129	CRPENR	94	DP251202	8, 9
CP807	66, 129	CRPENR	96	DP251203	8, 9
CP807-240	66, 129	CRPP2-1 thru CRPP2-24	98	DP252401	8, 9
CP815	66, 129	CRT	91	DP252402	8, 9
CP815-240	66, 129	CRT	94	DP252403	8, 9
CP816	66, 129	CRT	96	DP25241	8, 9
CP817	66, 129	CRT220	89	DP25242	8, 9
CP818	66, 129	CRT220	91	DP25243	8, 9
CP819	66, 129	CRT220	94	DP301201	8, 9
CP820	66, 129	CRT220	96	DP301202	8, 9
CP821	66, 129	CRT220UK	91	DP301203	8, 9
CPH100	81	CRT220UK	94	DP302401	8, 9
CPO70	81	CRTH2	89	DP302402	8, 9
CR1000-1 thru CR1000-24	92	CRTH2	89	DP302403	8, 9
CR15X370R thru CR80X370R	6	CRTH2	89	DP30241	8, 9
CR2X370 thru CR70X370	6	CRTH2-220	89	DP30242	8, 9
CR2X440 thru CR60X440	6	CRTP2-1 thru CRTP2-72	98	DP30243	8, 9
CR4CABLE	96	CRTT2-1 thru CRTT2-24	98	DP34	67
CR5X440R thru CR80X440R	6	CS124-156X165 thru CS270-324X165	7	DP401202	8, 9
CR87-1 thru CR87-24	92	CS21-25X110 thru CS1000-1200X110	7	DP401203	8, 9
CR87-57	93	CS21-25X220 thru CS270-324X220	7	DP402402	8, 9
CR87-59	93	CS21-25X330 thru CS324-388X330	7	DP402403	8, 9

# SUPCO Part Number Index

SUPCO PART NO.	Page	SUPCO PART NO.	Page	SUPCO PART NO.	Page
DP40242	8, 9	E3050C31	89	FB250	20
DP40243	8, 9	E3050C31	98	FB302	20
DP501203	8, 9	E3050C7	89	FB325	20
DP502403	8, 9	E3050C7	98	FB350	20
DP50243	8, 9	E40110F12	89	FB353	21
DP601203	8, 9	E40110F12	98	FB401	20
DP602403	8, 9	E40110F24	89	FB402	19
DP60243	8, 9	E40110F24	98	FB402	20
DP751203	8, 9	E40110F31	89	FB403	20
DP752403	8, 9	E40110F31	98	FB404	20
DP75243	8, 9	E40110F7	89	FB450	21
DP901203	8, 9	E40110F7	98	FB455	19
DP902403	8, 9	E545C12	89	FB455	21
DP90243	8, 9	E545C12	98	FB460	20
DPG100	69	E545C24	89	FB461	20
DPG1000	69	E545C24	98	FB501	20
DPG25V	69	E545C31	89	FB504	20
DPGT	94	E545C31	98	FB550	19
DPGT220EU	94	E545C7	89	FB550	20
DPGT220UK	94	E545C7	98	FB551	20
DPGT220US	94	ECAP321	56	FB590	20
DR10	97	EDT10	14	FB601	20
DR40	97	EDT11	14	FB604	20
DSP1000	71	EDT12	14	FB650	20
DTK-1-4LVLP-D	11	EDT12-20	14	FB651	20
DTK-1-4LVLP-LV	11	EDT13	14	FB660	20
DTK-1LVLP-D	11	EDT13-20	14	FB665	20
DTK-1LVLP-LV	11	EDT20	14	FB701	20
DTK-240-3CMPLUS	11	EDT21	14	FB702	20
DTK-2LVLP-SCP-RUV	11	ELB101	101	FB703	20
DTK-4LVLP	11	ELB201	101	FB718G	21
DVTH	82	ELB250	101	FB803	20
E20120F12	89	ELB251	101	FBP100	103
E20120F12	98	ELB301	101	FC1113	104
E20120F24	89	ELB304	101	FC1214	104
E20120F24	98	ELB305	101	FC1617	104
E20120F31	89	ELB312	101	FC1820	104
E20120F31	98	ELB320	101	FC2224	104
E20120F7	89	ELB321	101	FC4011	34
E20120F7	98	ELB340	101	FC4031	34
E2050F12	89	ELB400	102	FC0810	104
E2050F24	89	ELB400	103	FC0915	104
E2050F31	89	ELB402	102	FL135 thru FL350-50	41
E2050F31	98	ELB701	103	FL50	39
E2050F7	89	ELB710	103	FL60	39
E2050F7	98	ELB711	103	FLD135	41
E3010524	89	ELB713	102	FLD205	41
E3010C12	89	ELB714	101	FPT10	104
E3010C12	98	ELB717	100	FPT13	104
E3010C24	98	ELB721	103	FPT15	104
E3010C31	89	ELB910	100	FTV12	62
E3010C31	98	ELB913	100	FWB1	105
E3010C7	89	EVENT-6H	93	G403K	43, 44
E3010C7	98	EVENT-7D	93	GC401	15
E3050524	89	F3050C12	98	GC405	15
E3050C12	89	F336	55	GC410	15
E3050C12	98	FB101 thru FB109	21	GC501	15
E3050C24	98	FB152 thru FB191	21	GC503	15

# SUPCO Part Number Index

SUPCO PART NO.	Page	SUPCO PART NO.	Page	SUPCO PART NO.	Page
GC505	15	HS57014	115	L135DC	39
GC506	15	HS58128	115	L145DC	39
GC601	15	HS58520	116	L210DC	39
GC602	15	HS59128	115	L420	84, 86
GC604	15	HS59520	116	LCV	84, 86
GC607	15	HSINJ001	113	LD120 thru LD305	42
GC701	15	HSUVB001	112	LIT11TC	70
GC702	15	HT100	2, 125, 126, 127	LIT6	70
GC707	15	HT70	2, 125, 126, 127	LIT8B	70
GFK1	19	HT80	2, 125, 126, 127	LITH9B	87
HK7	105	HT90	2, 125, 126, 127	LLD032 thru LLD309S	25
HL758	38	HTP5	91	LLS	87
HP083 thru HP165S	27	HTP5	92	LLS	87
HS10001	112	HTP5100	91	LLSU	87
HS10004	112	HTP5100	92	LLSU	87
HS10016	112	HTP515	91	LPT	84, 86
HS10128	112	HTP515	92	LT2	84, 85
HS11001	112	HTP525	91	LTC	84, 85
HS11004	112	HTP525	92	LTH	84, 85
HS11016	112	HTP550	91	LTT	84, 85
HS11128	112	HTP550	92	M044	111
HS12001	112	HVT2	104	M098	111
HS15128	115	IAQ50	79	M444	111
HS15128	117	IAQ55	79	M500	77
HS16001	114	IC100	60	M501	77
HS16501	114	IC102	60	M814520	13
HS17001	112	ICG1	58	MCASE	77
HS17004	112	ICG-220	58	MCASE	96
HS17016	112	IG4000	43	MD5	24
HS18004	114	IG401	43, 44	MD6	24
HS20004	113	IG402K	43, 44	MD7	24
HS20016	113	IG405	43, 44	MFD10	77
HS20128	113	IG406	43, 44	MFDCASE	68, 69
HS21004	113	IG412	43, 44	MFDCASE	77
HS21016	113	IG414	43, 44	MFDfuse	77
HS21128	113	IM1	105	MTM1028	80
HS22008	113	IM2	105	OL1	60
HS22032	113	IM3	105	OL2	60
HS22128	113	IM4	105	OL3	60
HS23008	113	IM5	105	OL4	60
HS23032	113	IMK3	105	OPR021	59
HS23128	113	KA12	117	OV32	60
HS24000	114	KEL	93	OV34	60, 61
HS24010	114	KES	93	OV36	60, 61
HS24128	114	KEV	93	OV38	60, 61
HS26004	113	KPP	96	OV40	60, 61
HS26016	113	KPT	97	OV42	60, 61
HS26128	113	KTE	96	OV44	60, 61
HS30004	112	KTE	97	OV46	60, 61
HS30016	112	KTH	89	OV48	60, 61
HS50004	116	KTH	91	OV50	60
HS51032	114	KTH	96	P89	104
HS52032	116	KTH	97	PC6	96
HS52105	116	KTP	96	PIT1	70
HS52115	116	KTP	97	PO115	58
HS52128	116	KTT	96	PO230	58
HS55032	115	KTT	97	POP3	56
HS56011	115	L120 thru L340	42	POP5	56

# SUPCO Part Number Index

SUPCO PART NO.	Page	SUPCO PART NO.	Page	SUPCO PART NO.	Page
PRO21	58	S814120	13	SF3604	62
PRO22	58	S814500	13	SF3605	62
PRO41	58	S814520	13	SF3606	62
PRO42	58	SA1	62	SF3608	62
PRO62	58	SA2	62	SF3800	65
PRO81	58	SAB233	99	SF3813	65
PRO82	58	SAB243	99	SF3900	65
PT100	71, 72	SAB444	99	SF3910	65
PT100C	71	SAB454	99	SF3920	65
PT100H	71	SAB515	99	SF3930	65
PT100HC	71	SAB710	99	SF3970	65
Q101 thru Q116	36	SAR21	106	SF4040	63
RC1220	102	SB001	20	SF4311	65
RC2106	102	SC1002	15	SF4311	104
RC2108	102	SCASE	78	SF4314	65
RC2110	102	SCCP	81	SF4450	63
RC2112	102	SCDM	81	SF5014	64
RC3110	102	SCM	10, 128	SF5050	64
RC3114	102	SCM1	10	SF5161	63
RC5003	100	SCMPLUG	11	SF5421	62
RC5010	100	SCMPLUS	10, 128	SF5501	61
RC5019	100	SCR11	91	SF5501	63
RCB1	105	SCR12	91	SF5512	63
RCO210	58	SD100F7	94	SF5514	63
RCO220	58	SD120F24	94	SF5516	63
RCO410	58	SD120F7	94	SF5518	63
RCO420	58	SD50C7	94	SF5534	63
RCO620	58	SF0099	61	SF5538	63
RCO810	58	SF0101	61	SF5555	65
RCO820	58	SF0111	61	SF5558	63
R041	58	SF1010	62	SF5578	63
R042	58	SF1060	61	SF8400	63
R062	58	SF1090	61	SF8403	63
R081	58	SF1414	63	SF8404	63
R082	58	SF1818	63	SF8404	63
RPT61	78	SF2010	64	SF8405	63
RSC20	58	SF2012	64	SF8406	63
RW516	105	SF2020	64	SF8412	63
RW916	105	SF2028	64	SF8414	63
RWA10	105	SF2035	64	SF8416	63
S0100	111	SF2060	64	SF8418	63
S0100F24	94	SF2070	64	SF8434	63
S0100F7	94	SF2090	64	SF8458	63
S045C24	94	SF2235	63	SF8478	63
S045C7	94	SF2245	63	SF8725	64
S20120F24	94	SF2250	63	SF9601	64
S20120F7	94	SF2525	62	SF9602	64
S210 thru S220	24	SF2595	64	SF9603	64
S3050C24	94	SF2597	64	SF9613	65
S3050C7	94	SF3500	103	SF9614	65
S4590F24	94	SF3510	103	SF9615	65
S4590F7	94	SF3515	103	SF9616	65
S8	111	SF3525	103	SF9620	65
S804100	13	SF3535	103	SF9644	65
S804120	13	SF3570	103	SFC75120 thru SFC300400	23
S804500	13	SF3600	62	SFPC	41
S804520	13	SF3602	62	SG3970	104
S814100	13	SF3603	62	SG4314	104

# SUPCO Part Number Index

SUPCO PART NO.	Page	SUPCO PART NO.	Page	SUPCO PART NO.	Page
SGV05 thru SGVA2	107	SLS140	38	SR4-20	90, 91
SH201 thru SH207	67	SLS145	38	SR6N1	106
SH221 thru SH226	67	SLS150	38	SRB	90, 91
SH250	67	SLS155	38	SRC	90, 91
SH251 thru SH252	67	SLS160	38	SRJ	90, 91
SH281 thru SH284	67	SLS165	38	SRL130	38
SH500 thru SH505	67	SLS170	38	SRL135	38
SHF110 thru SHF250	39	SLS175	38	SRL220	38
SHF90	39	SLS180	38	SRL230	38
SHL120 thru SHL325	39	SLS200	38	SRL240	38
SHL501 thru SHL519	37	SLS250	38	SRL250	38
SHM125 thru SHM350	37	SLS255	38	SRL260	38
SHP200150 thru SHP610420	22	SLS265	38	SRL300	38
SHS03 thru SHSA2	107	SLS275	38	SRL300ICP	38
SHS50	67	SLS285	38	SRL350	38
SIG100 thru SIG111	47, 48, 49	SLS295	38	SRTH	90, 91
SIG1100	47, 48, 49	SLS300	38	SRV	90, 91
SIG401 thru SIG414	47, 48, 49	SLS300HB	38	SRVLA	91
SIS018	56	SLS350	38	SS410	58
SK3W2	3	SM140-40A	18	SSGFM2 thru SSGFM4	28
SK3W3	3	SM550 thru SM556	17	SSGSS2 thru SSGSS5	28
SK3W4S	3	SM670 thru SM681	18	SSGSS7	28
SK3W5	3	SM6700B	19	SSLD83 thru SSLD419S	26, 27
SK3W6S	3	SM683	18	SSN2000	45, 46
SL300T	88	SM684	18	SSN24	47, 48, 49
SL300TH	88	SM685	18	SSN3000	45, 46
SL5703	40	SM690C	18	SSN3016	45, 46
SL5708	40	SM691	18	SSN4000	45, 46
SL79002	40	SM692	18	ST01 thru ST04	73
SL79005	40	SM700 thru SM705	17	ST06 thru ST08	73
SLF130VA	38	SM775	18	ST09	73
SLF155VA	38	SM998	17	ST10	73
SLF158VB	38	SM999	17	ST200	111
SLF165VA	38	SMR375 thru SMR610	22, 23	STC4162 thru STC6377	40
SLF170VA	38	SP12C	56	STC4257	33
SLF185VB	38	SP18	56	STC4283	33
SLF190HA	38	SP18C	56	STC4300	33
SLF194HB	38	SP2	56	STC4333	33
SLF194VB	38	SP2C	56	STC4358	33
SLF200HA	38	SP3	56	STC4438	33
SLF200VA	38	SP3C	56	STC4468	33
SLF210HA	38	SP4	56	STC5257	33
SLF222VA	38	SP4C	56	STC5300	33
SLF230HA	38	SP6	56	STC5333	33
SLF230HB	38	SP6C	56	STC5337	33
SLF250HA	38	SPP	3	STC5377	33
SLF252VB	38	SPP10E	3	STC6257	33
SLF255VA	38	SPP4E	3	STC6300	33
SLF260HA	38	SPP5	3	STC6333	33
SLF275HB	38	SPP5E	3	STD5-105	72
SLF275VB	38	SPP5TD	5	STF4170 thru STF4305B	40
SLF280HB	38	SPP6	3	STV2	62
SLF300HB	38	SPP6E	3	STV2D	62
SLF300VA	38	SPP6TD	5	STV3	62
SLF330VA	38	SPP7E	3	STV4	62
SLP0520 thru SLP90120	22	SPP7S	3	SUD103	23
SLS120	38	SPP8E	3	SUD109 thru SUD116	23
SLS130	38	SPP9E	3	SUPR	4

# SUPCO Part Number Index

SUPCO PART NO.	Page	SUPCO PART NO.	Page	SUPCO PART NO.	Page
SW100	75	TCW75	94	V40110F31	98
SW100	87	TD68	16	V40110F7	98
SW25	75	TD69	16	V545C12	98
SW25	87	TD69W	16	V545C24	98
SW50	75	TD72	16	V545C34	98
SW50	87	TD73	16	V545C7	98
SW75	75	TD73W	16	VG60	68, 69
SW75	87	TDP269	5	VG61	68, 69
SWC03 thru SWCA1	107	TH7001	39	VG64	68, 69
SXT 79R	35	TH7010	39	VG64S	68, 69
SXT100R	35	THA2	75	VG65	68, 69
SXT101	35	THA2P	75	VG66	68, 69
SXT103 thru SXT106	35	THC120	73	VGC	68, 69
SXT111 thru SXT116	35	THP2	73	VLCEL	83
SXT148	35	THP5	94	VLPAPER	83
SXT150	35	THS60	106	VLS CABLE	83
SXT160	35	TLA	81	VLSK	83
T1001 thru T1197	107, 108, 109, 110	TP15	91	VLT	83
T1121 thru T1125	42	TP15	96	VLT PROBE	83
T2001 thru T2112C	107, 108, 109, 110	TP6	96	VLT4-115	83
T45	34	TPFDA	78	VLT4-12	83
TA2	74	TPFDA	81	VLT4-230	83
TA22	74	TPFDA	87	VLTH PROBE	83
TA2-220	74	TPM110	73	VLTH-115	83
TA2-220C	74	TPMP2	12	VLTH-12	83
TA2C	74	TPMPU	12	VLTH-230	83
TA3001	106	TPP	78	VLWPCASE	83
TA3-220	76	TPS	78	VPR	83
TA3C	76	TTP5	94	VSG	68, 69
TA3C220	76	UFC1	104	WA100	80
TA3P	75	UPR041	59	WH3	14
TA3P	76	UPR081	59	WH4	14
TA6	74	UR041	59		
TA6220	74	URCO210	59		
TA6C	74	URCO210RC	59		
TA6C220	74	URCO410	59		
TA7	74	URCO410RC	59		
TA7C	74	URCO810	59		
TA7PROBE	75	URCO810RC	59		
TAL2	76	URO81	59		
TAP4	76	URSC10	59		
TAP4-220	76	USBS	75		
TAP4-220	76	USBS	87		
TAP4C	76	UW1	105		
TC103	106	V20120F31	98		
TC104	106	V20120F7D	98		
TC2	104	V2050F12	98		
TCW100	75	V2050F31	98		
TCW100	91	V2050F7	98		
TCW100	94	V3010C12	98		
TCW25	75	V3010C24	98		
TCW25	91	V3010C31	98		
TCW25	94	V3010C7	98		
TCW50	75	V3050C24	98		
TCW50	91	V3050C31	98		
TCW50	94	V3050C7	98		
TCW75	75	V40110F12	98		
TCW75	91	V40110F24	98		

Keep Scrolling  
Down

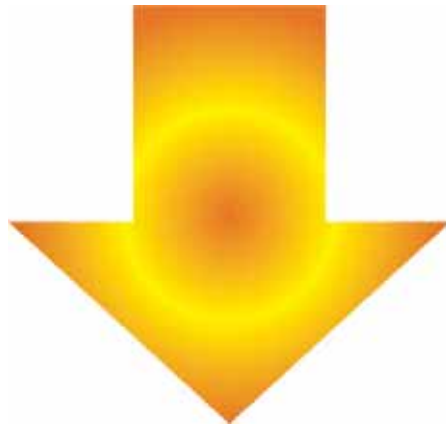

# AC Hard Starts

## A/C Hard Starts

Choosing the correct hard start for the application combines a technical need with a professional preference. Select from the broadest offering of Hard Starts from the Pioneer of Hard Start technology.

### Four (4) styles to choose from:

- **HT Series** High Torque Series Relay (EPR)/Capacitor combination
- **SPPE Elite Series** Electronic Potential Relay (EPR)/Capacitor combination
- **SPP Series** PTC/Capacitor combination
- **SK3W Series** 3-wire Potential Relay/Capacitor combination

### Applications

- Use on any single phase air conditioner or refrigeration unit
- Low voltage situations
- Hard starting compressors



**NATE Recognized Course 1867-0002**  
**SUPCO Hard Start Kits**

## HT Series - HIGH TORQUE Hard Start Kits

Matching a high current potential relay with a high voltage capacitor means the ultimate *Torque* for the most reliable Hard Start Kits. Choose from 4 sizes for the best solution.



### Features/Benefits

- Device includes high current potential relay and 330 VAC start capacitor.
- 40 Amp Electronic Potential relay (EPR) provides superior performance for low voltage applications.
- Senses Motor Start
- Instant Re-start
- Safety time delay if compressor fails to start
- Easy 2-wire installation
- Made in the USA
- UL recognized

### Applications

- For use on ALL types of single phase 208 – 277 VAC air conditioning, heat pump and refrigeration compressors; including reciprocating, scroll and rotary from 1 – 5 hp.



### Product Information

SUPCO. PART NO.	RECOMMENDED RANGE	APPLICATION	INCREASE IN TORQUE (%)	CAPACITOR DIMENSIONS	CAPACITOR SPECIFICATIONS	REPLACES KICKSTART
HT70	1-3 hp	Cap Tube & Orifice Metering Devices	1000 %	6 3/4"L X 1 9/16"W X 2 1/2"H	108-130 μF X 330 VAC	KS8
HT80	1-3 hp	All Metering Devices	1000 %	6 3/4"L X 1 9/16"W X 2 1/2"H	189-227 μF X 330 VAC	TO-5
HT90	Maneurop Compressors	All Maneurop Compressors +	1000 %	6 3/4"L X 1 9/16"W X 2 1/2"H	233-280 μF X 330 VAC	MP1
HT100	3.5 - 5 hp	All Metering Devices	1000 %	6 3/4"L X 1 9/16"W X 2 1/2"H	270-324 μF X 330 VAC	KS1

+ Use HT80 for M/N's MT18JA\* MTEJA\* & MTZ18JA\*

**\* For HT Cross Reference refer to page 125 -127**

Hard Start Comparison Selection Table	HT Series	SPPE Series	SK3W Series	SPP Series
Start Sensing Technology	Voltage	Voltage	Voltage	NA
Uses Electronic Potential Relay (EPR)	Yes	Yes	Yes	No
Instant Re-Start	Yes	Yes	Yes	No
Senses Motor Start	Yes	Yes	Yes	No
Two wire, non-polarized	Yes	Yes	No	Yes
OEM Style, 3-wire	No	No	Yes	No
Replaces 3-wire capacitor kit	Yes	Yes	Yes	Yes
UL approved	Yes	Yes	Pending	Yes
PTCR Device	No	No	No	Yes
Backup Timing Safety Circuit	Yes	Yes	No	No
Potentially damaging to motor windings	No	No	No	No
Requires non-replaceable fuse protection	No	No	No	No
330V Capacitor	Yes	Yes	Yes	No

### Potential Relay Devices

The Potential Relay start device has recently been the subject of considerable attention in the market place. Several manufacturers are promoting products with a variety of technologies. The primary distinction between the potential relay devices relates to a voltage sensing or current sensing capability.

The voltage sensing method monitors start winding developed voltage and actuates a mechanical or electronic potential relay to disengage the start capacitor. The electronic potential relay is inherently more reliable and precise than the older type mechanical potential relay. SUPCO employs voltage sensing technology with an electronic potential relay.

# AC Hard Starts



See Page 123-124  
for E Class Advantage  
Tech Notes

## SPPE 'E Class' Series EPR/Capacitor Combination

### Features/Benefits

- Electronic Potential Relay Technology (EPR)
- Backup electronic timing circuit to protect the compressor
- Voltage sensing
- Instant Re-start
- Easy 2-wire installation
- Can be used on PSC and CSIR type compressors
- 330 V Capacitor



PART NO.	OPERATING		
	VOLTAGE (VAC)	RECOMMENDED RANGE (hp)	CAPACITOR SIZE ( $\mu$ F)
SPP4E	90 – 130	1/8 – 1	88 – 106
SPP5E	170 – 277	1/3 – 2	43 – 52
SPP6E	170 – 277	1/2 – 3	88 – 106
SPP7E	170 – 277	1 – 4	130 – 156
SPP8E	170 – 277	1 and up	189 – 227
SPP9E	170 – 277	1 and up	233 – 280
SPP10E	170 – 277	3 and up	270 – 324



## SPP Series PTC/Capacitor Combination

### Features/Benefits

- Positive Temperature Coefficient Technology (PTC)
- Field proven reliability
- Easy 2-Wire installation
- Most economic



PART NO.	VOLTAGE (VAC)	RECOMMENDED RANGE (hp)	INCREASE IN TORQUE (%)
SPP*	90 – 277	1/2 to 10	250%
SPP5	90 – 277	1/2 to 10	300%
SPP6	90 – 277	1/2 to 10	500%
SPP7S	90 – 277	1/2 to 10	600%

\* This model does not include a capacitor



## SK3W Series 3-Wire Potential Relay/Capacitor Combination

### Features/Benefits

- OEM-Style 3-wire Installation
- Instant re-start
- Easy installation with "fast clamp-on" connection
- Models for standard and scroll compressors
- 330 VAC Start Capacitor Voltage



PART NO.	hp RATINGS	COMPRESSOR	DROP-OUT VOLTAGE (VAC)	PICK-UP VOLTAGE (VAC)	MAXIMUM COIL VOLTAGE	CAPACITOR SIZE ( $\mu$ F)
SK3W2	1 thru. 2 hp	Standard	60-135	204-233	500 VAC	88 - 108
SK3W3	2 1/2 thru. 3 1/2 hp	Standard	60-121	171-184	420 VAC	189 - 227
SK3W5	4 thru. 5 hp	Standard	60-121	171-184	420 VAC	243 - 292
SK3W4S	3 thru. 4 hp	Scroll	60-135	204-233	500 VAC	189 - 227
SK3W6S	4 1/2 thru. 6 hp	Scroll	60-121	171-184	420 VAC	270 - 324

### Application Note: 2-wire vs. 3-wire Installation

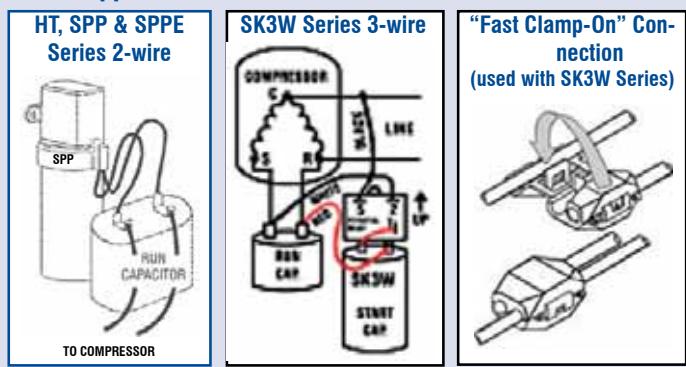

# Relays

## Universal Potential Relays

**Note:** See Technical Area for Application Note on Relays

Replacing all potential relays, these WIRE TO WIRE Universal Potential Relays offer the ultimate in convenience. One potential relay to fit any application. Choose to “drop in” the SUPR Universal Potential Relay or “dial in” the exact pick-up voltage for the APR5 Adjustable Potential Relay. State of the Art electronic circuitry provides Wire to Wire replacement of any potential relay with added motor protection.

### Applications

- Replaces all OEM potential relays
- Use on any single phase motor or air conditioning and refrigeration compressor up to 5 hp.

### Features/Benefits

- Reduces inventory
- Wire to Wire Replacement for virtually ALL potential relays.
- Recycles instantly
- Replaces both 3 and 5 terminal potential relays
- Normally closed contacts

- Accommodates screw-on or push-on connections.
- Dimensions identical to industry standard potential relays.
- Easy replacement mounting with universal mounting bracket.
- Start winding protection if motor does not start.
- Prevents start capacitor venting when motor doesn't start.
- Contact Material: Silver Cadmium Oxide



### SUPR Universal Potential Relay

- Time Function Relay
- Start Time: 1.0 - 1.5 seconds



### APR5 Adjustable Potential Relay

- Adjustable, Voltage Sensitive Relay
- Set pick-up voltage
- Safety time out 1.0 – 1.5 seconds

### Common Specifications

Operating Voltage	110 – 270 VAC, Single Phase
Amperage	30 AMP
Motor Power Rating	up to 5 hp
Operating Position	Non-positional mounting.
Universal Mounting Bracket	Allows for easy installation. Unused portions of the bracket simply snap off with pliers.
Terminals	Screw or push-on. Adapters to convert screw-on to push-on are provided.
Dimensions	1.75W x 2.25L x 1.50H

## 90X Series Potential Relays

- Meets all requirements of OEM relays
- Universal break-off bracket



### Features/Benefits

- 50/60 cycle
- Contact rating 35 amp @ 277 VAC
- Non-positional
- Instructions and wiring diagram included in each relay

PART NO.	CONTINUOUS		DROP		OUT RELAY GROUPS*	REPLACES GE 3ARR
	COIL VOLTAGE	PICK-UP MIN.	PICK-UP MAX.	MAX.		
9063	170	139	153	55	2J; 2K; 2L; 2M; 5N; 7J; 7K; 7L; 7M; 7N; 8L; 8M; 8N	
9064	395	260	275	120	3A; 3B; 3AV; 3AU; 4A; 4B; 6A; 6B; 6AV; 10A; 10B; 10AU; 10AV; 14A; 14B; 16A	
9065	332	168	182	90	3P; 3R; 3AP; 5P; 5R; 5S; 5T; 13P; 19N; 22S	
9066	395	215	225	120	3U; 3V; 3AT; 6U; 6V; 6W; 16U	
9067	420	295	315	125	3C; 3D; 3AA; 4C; 4D; 4BK; 6C; 6D; 6AA; 10C; 10D; 26A; 26B; 26C; 26D	
9068	502	325	345	135	3E; 3F; 3AB; 3AC; 4E; 4F; 4G; 6E; 6F; 6G; 10H; 10AB; 10AC; 26E; 26F; 26G; 26H; 27E; 27F; 27G	
9069	336	180	195	105	3S; 3T; 10S; 10T; 10AS; 13S; 13T; 20S; 25S; 25T	
9070	253	285	305	77	5B; 5C; 5D; 5AA; 8B; 8C; 8D; 27A; 27B; 27C	
9071	420	212	232	121	6TV; 6TW; 10V; 16TV; 20V	

\*Determine group from GE part number.



## 903X Series General Purpose Switching Relays

Double pole – double throw (DPDT)



### Applications

- HVAC/ R
- Appliance vending machines
- Fan controls
- Business machines



PART NO.	COIL VOLTAGE	TERMINAL 1-2-3	TERMINAL 4-5-6	CROSS REFERENCE	
				ESSEX/RBM	HONEYWELL
90340	24	power	power	90-340	R8222D1014
90341	110/12	power	power	90-341	R4222D1013
90342	208/240	power	power	90-342	R4222N1021

CONTACT RATINGS	POWER 208/240V208/240V		PILOT	
	120V	277V	120V	277V
Full Load Amps	12	6	-	-
Resistive Amps*	15	15	3	3
Locked Rotor Amps	60	35	-	-
Horsepower	3/4	3/4	1/10	1/10

\*0.75 power factor

## 902XX & 903XX Series General Purpose Fan Relays



### Engineering Data

- **CONTACTS:** SPST-NO, SPST-NC, SPDT, 1 NO/1 NC, Material/ Power - Silver Alloy, Material 1/2 Pilot - Fine Silver
- **POWER RATINGS (All Forms):** 125 VAC, 18A Resistive, 12 FLA, 60 LRA, 240/277 VAC, 18A Resistive, 8 FLA, 48 LRA
- **SPECIAL POWER RATINGS (Form 1 & 2):** 125 VAC, 14 FLA, 84 LRA, 277 VAC, 25A Resistive
- **PILOT RATINGS (All Forms):** 3A, 277 VAC Gen. Purpose, 250 VA @ 250 VAC, 277 VA @ 277 VAC, 125 VA @ 125 VAC
- **COILS :** Voltage Ratings - 24, 120, 208/240, 77 VAC, 12, 24 VAC Frequency - 50/60 Hz Pick-up Voltage - AC 85% of nominal, DC 75% of nominal, Power Ratings -AC DC, Inrush 5 VA 3VA, Sealed 3 VA 3 VA

PART NO.	DESCRIPTION	AMPS	COIL VOLTAGE
90290	SPST	4	24V
90291	SPST	4	120V
90292	SPST	4	240V
90293	SPDT	1	24V
90294	SPDT	1	120V
90295	SPDT	1	240V
90370	SPDT	12	24V
90372	SPDT	12	120V
90374	SPDT	12	240V
90380	NO/NC	13	24V
90382	NO/NC	13	120V
90384	NO/NC	13	240V

### Wiring Diagrams

902XX / SPST

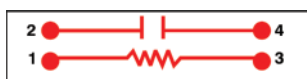

902XX / SPDT

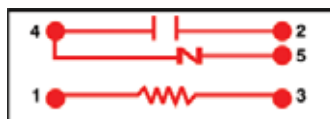

903XX / SPDT

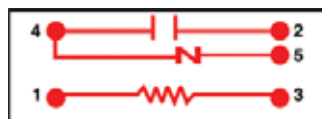

903XX / SPNO / SPNC

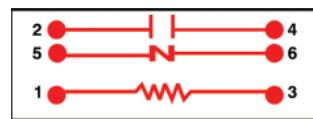

## Short Cycle Protector, Time Delay Relay and Contactor Combination

- Choose Delay on Break or Delay on Make model
- Ideal for split systems not supplied with contactor or time delay relay

- Prevents short cycling
- Contactor takes compressor load off the thermostat circuit

### Features/Benefits

- Adjustable Delay
- Relay coil same voltage as load
- 1/4" male quick connect terminals
- Encapsulated circuitry
- Input Voltage: 208 - 230 VAC

PART NO.	DELAY TYPE	DELAY RANGE
TDP269	Delay on Make (DOM)	6 sec. to 300 sec.

## Compressor Protection Package Combination

Combines Hard Start Kit with maximum compressor protection.



### Features/Benefits

- Can be installed in pilot circuits for 24 to 288 VAC
- Adjustable time delay from 6 seconds to 5 minutes
- Operates with or without cooling thermostat anticipator
- Only two terminal connection on Time Delay
- Can be mounted as an assembly or snapped apart for separate mounting
- Two models available to suit specific requirements

### Applications

- Residential and commercial PSC A/C units and heat pumps
- For all PSC A/C units from 1 hp to 10 hp
- Can be used on 115 thru 288 VAC units
- For severe low voltage or hard starting compressors

PART NO.	INCREASED TORQUE	TIME DELAY RANGE
SPP5TD	270 ounce inches (300%)	6 sec. to 5 minutes
SPP6TD	390 ounce inches (500%)	6 sec. to 5 minutes

### Facts About Capacitors

- Capacitors are rated by microfarads (uF) and voltage. The rated capacitor should not be changed since the motor operates at maximum efficiency when using a specified capacitor size. However a plus or minus 10 % rule of thumb applies to the microfarad rating when changing out a capacitor. If necessary, the replacement capacitor voltage rating can be higher than specified, but not lower without effecting the capacitor life.
- Always replace the run capacitor when installing a new motor. If a defective capacitor is in the circuit the motor will probably not run. If it does run, it will operate as if it is overloaded. The motor speed will be low; it will overheat and probably activate the motor overload protector causing short cycling.
- Capacitors can hold a charge for long periods of time. To prevent shock the capacitor should be discharged before it is removed. The proper procedure to do this is to use a 5000 to 20000 Ohm bleed resistor.
- To check capacitors, use a SUPCO Capacitor Tester p/n MFD10.

# Capacitors



## Motor Run Capacitors

### Features

- Non – PCB biodegradable synthetic oil
- Physical interrupter for safety
- Operating temperature –13°F to + 185°F (- 25°C to + 85°C)
- Microfarad  $\mu\text{F}$  tolerance +/- 5 %
- Drawn steel case construction
- Quad blade quick connect terminals
- Hermetically sealed

### Applications

- Air Conditioning Compressors
- Refrigeration Compressors
- Furnace Blower Motors
- Condenser Fan Motors

## SINGLE - OVAL

### 370 VOLT

PART NO.	$\mu\text{F}$
CR2X370	2
CR3X370	3
CR4X370	4
CR5X370	5
CR6X370	6
CR7.5X370	7.5
CR10X370	10
CR12.5X370	12.5
CR15X370	15
CR17.5X370	17.5
CR20X370	20
CR25X370	25
CR30X370	30
CR35X370	35
CR40X370	40
CR45X370	45
CR50X370	50
CR55X370	55
CR60X370	60
CR70X370	70

### 440 VOLT

PART NO.	$\mu\text{F}$
CR2X440	2
CR3X440	3
CR4X440	4
CR5X440	5
CR6X440	6
CR7.5X440	7.5
CR10X440	10
CR12.5X440	12.5
CR15X440	15
CR17.5X440	17.5
CR20X440	20
CR25X440	25
CR30X440	30
CR35X440	35
CR40X440	40
CR45X440	45
CR50X440	50
CR55X440	55
CR60X440	60

## SINGLE - ROUND

### 370 VOLT

PART NO.	$\mu\text{F}$
CR15X370R	15
CR20X370R	20
CR25X370R	25
CR30X370R	30
CR35X370R	35
CR40X370R	40
CR45X370R	45
CR50X370R	50
CR55X370R	55
CR60X370R	60
CR70X370R	70
CR80X370R	80

### 440 VOLT

PART NO.	$\mu\text{F}$
CR5X440R	5
CR10X440R	10
CR15X440R	15
CR20X440R	20
CR25X440R	25
CR30X440R	30
CR35X440R	35
CR40X440R	40
CR45X440R	45
CR50X440R	50
CR55X440R	55
CR60X440R	60
CR70X440R	70
CR80X440R	80

## DUAL - OVAL

### 370 VOLT

PART NO.	$\mu\text{F}$
CD15+5X370	15+5
CD15+10X370	15+10
CD20+5X370	20+5
CD20+15X370	20+15
CD25+3X370	25+3
CD25+5X370	25+5
CD25+10X370	25+10
CD30+3X370	30+3
CD30+5X370	30+5
CD30+7.5X370	30+7.5
CD35+3X370	35+3
CD35+5X370	35+5
CD35+7.5X370	35+7.5
CD35+10X370	35+10
CD40+5X370	40+5
CD45+5X370	45+5
CD55+5X370	55+5
CD55+7.5X370	55+7.5
CD60+10X370	60+10

### 440 VOLT

PART NO.	$\mu\text{F}$
CD20+5X440	20+5
CD25+5X440	25+5
CD25+7.5X440	25+7.5
CD25+10X440	25+10
CD30+5X440	30+5
CD35+5X440	35+5
CD35+7.5X440	35+7.5
CD40+5X440	40+5
CD40+7.5X440	40+7.5
CD45+5X440	45+5
CD45+7.5X440	45+7.5
CD50+5X440	50+5
CD55+5X440	55+5
CD55+10X440	55+10
CD60+5X440	60+5

## DUAL - ROUND

### 370 VOLT

PART NO.	$\mu\text{F}$
CD20+5X370R	20+5
CD20+7.5X370R	20+7.5
CD25+3X370R	25+3
CD25+4X370R	25+4
CD25+5X370R	25+5
CD30+3X370R	30+3
CD30+5X370R	30+5
CD35+5X370R	35+5
CD40+5X370R	40+5
CD45+5X370R	45+5
CD80+5X370R	80+5
CD80+7.5X370R	80+7.5

### 440 VOLT

PART NO.	$\mu\text{F}$
CD20+5X440R	20+5
CD25+5X440R	25+5
CD25+7.5X440R	25+7.5
CD30+5X440R	30+5
CD30+7.5X440R	30+7.5
CD35+5X440R	35+5
CD35+7.5X440R	35+7.5
CD35+10X440R	35+10
CD40+5X440R	40+5
CD40+7.5X440R	40+7.5
CD40+10X440R	40+10
CD45+5X440R	45+5
CD45+7.5X440R	45+7.5
CD50+5X440R	50+5
CD50+7.5X440R	50+7.5
CD55+5X440R	55+5
CD55+7.5X440R	55+7.5
CD55+10X440R	55+10
CD60+5X440R	60+5
CD60+7.5X440R	60+7.5
CD80+5X440R	80+5
CD80+7.5X440R	80+7.5
CD80+10X440R	80+10

# Capacitors



## Motor Start Capacitors

UL approved Start Capacitors available in 110 VAC, 165 VAC, 220 VAC and 330 VAC.



### Features

- Dry, electrolytic, no polarized type for intermittent duty in AC motors and compressors.
- Used where starting torques must be higher in relation to running torques.
- Moisture and oil resistant molded phenolic resin or plastic material.
- Standard dual blade terminals.
- Industry standard case sizes.

compressors.

### 110 VAC

PART NO.	VALUE (µF)	CASE SIZE
CS21-25X110	21-25	1
CS25-30X110	25-30	1
CS30-36X110	30-36	1
CS36-43X110	36-43	1
CS43-56X110	43-56	1
CS56-72X110	56-72	1
CS64-77X110	64-77	1
CS72-88X110	72-88	1
CS88-108X110	88-108	1
CS108-130X110	108-130	1
CS124-156X110	124-156	1
CS145-175X110	145-175	1
CS161-193X110	161-193	1
CS189-227X110	189-227	1
CS200-240X110	200-240	2
CS216-259X110	216-259	2
CS233-292X110	233-292	4
CS270-324X110	270-324	4
CS300-360X110	300-360	4
CS324-388X110	324-388	4
CS340-408X110	340-408	4
CS378-440X110	378-440	4
CS400-480X110	400-480	5
CS460-552X110	460-552	5
CS540-648X110	540-648	5
CS590-708X110	590-708	5
CS708-850X110	708-850	7
CS829-995X110	829-995	8
CS1000-1200X110	1000-1200	8

### 165 VAC

PART NO.	VALUE (µF)	CASE SIZE
CS124-156X165	124-156	4
CS145-175X165	145-175	4
CS161-193X165	161-193	4
CS233-292X165	233-292	5
CS270-324X165	270-324	5

### 220 VAC

PART NO.	VALUE (µF)	CASE SIZE
CS21-25X220	21-25	1
CS25-30X220	25-30	1
CS30-36X220	30-36	1
CS36-43X220	36-43	1
CS43-56X220	43-56	2
CS56-72X220	56-72	2
CS64-77X220	64-77	4
CS72-88X220	72-88	4
CS88-108X220	88-108	4
CS108-130X220	108-130	4
CS124-156X220	124-156	5
CS145-175X220	145-175	7
CS161-193X220	161-193	7
CS189-227X220	189-227	7
CS216-259X220	216-259	8
CS233-292X220	233-292	8
CS270-324X220	270-324	8

### 330 VAC

PART NO.	VALUE (µF)	CASE SIZE
CS21-25X330	21-25	1
CS25-30X330	25-30	1
CS30-36X330	30-36	4
CS36-43X330	36-43	4
CS43-56X330	43-56	4
CS53-70X330	53-70	5
CS56-72X330	56-72	5
CS72-88X330	72-88	5
CS88-108X330	88-108	7
CS108-130X330	108-130	8
CS124-156X330	124-156	8
CS130-156X330	130-156	8
CS145-175X330	145-175	8
CS161-193X330	161-193	8
CS189-227X330	189-227	8
CS216-259X330	216-259	8
CS270-324X330	270-324	8
CS324-388X330	324-388	8

### Case Dimensions

CASE SIZE	DIAMETER	HEIGHT
1	1 7/16"	2 3/4"
2	1 7/16"	3 3/8"
4	1 13/16"	3 3/8"
5	1 13/16"	4 3/8"
6	2 1/16"	3 3/8"
7	2 1/16"	4 3/8"
8	2 9/16"	4 3/8"

### Wiring Diagrams for Run Capacitors

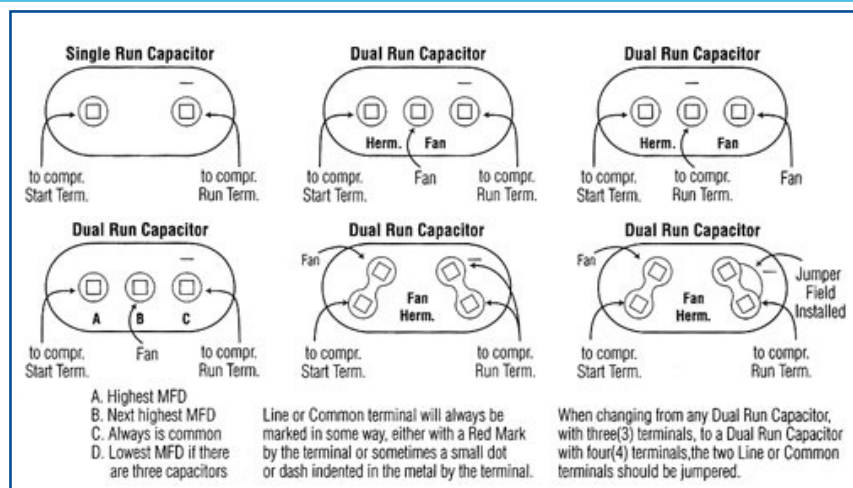

# Contactors

## SUPCO Brand Definite Purpose Contactors

SUPCO contactors are designed for use in HVAC&R systems. These contactors are available in 1.5, 2 and 3 pole configurations from 20 through 90 full amps. Compact universal design allows replacement of the most common brands.



### Features

- Silver Cadmium Oxide Contacts
- Ranges: 20 – 90 FLA
- Poles: 1.5, 2 & 3
- Coil Voltages: 24, 120 & 240 VAC
- Terminations: #10-32 screw – 20, 25 & 30 FLA Models, Box Lug – 40, 50, 60, 75 & 90 FLA Models
- Temperature Range: - 40°F to + 150°F / (- 40°C to + 65°C)
- UL & CSA Approved

### Benefits

- Economically priced
- Space saving dimensions allow for smaller panels and more wiring room.
- Interchangeable mounting with many competitive contactors.
- Complete competitive cross-reference available.

### Applications

- Low drop out voltage making them ideal for any air conditioning, heating and refrigeration application.



1.5 POLE PART NO.	FULL LOAD AMPS	COIL VOLTAGE
DP25241	25	24
DP251201	25	120
DP252401	25	240
DP30241	30	24
DP301201	30	120
DP302401	30	240

2 POLE PART NO.	FULL LOAD AMPS	COIL VOLTAGE
DP20242	20	24
DP201202	20	120
DP202402	20	240
DP25242	25	24
DP251202	25	120
DP252402	25	240
DP30242	30	24
DP301202	30	120
DP302402	30	240
DP40242	40	24
DP401202	40	120
DP402402	40	240

3 POLE PART NO.	FULL LOAD AMPS	COIL VOLTAGE
DP25243	25	24
DP251203	25	120
DP252403	25	240
DP30243	30	24
DP301203	30	120
DP302403	30	240
DP40243	40	24
DP401203	40	120
DP402403	40	240
DP50243	50	24
DP501203	50	120
DP502403	50	240
DP60243	60	24
DP601203	60	120
DP602403	60	240
DP75243	75	24
DP751203	75	120
DP752403	75	240
DP90243	90	24
DP901203	90	120
DP902403	90	240

### Contactor Nomenclature

Example: DP30242  
 DP = Definite Purpose  
 30 = Full Load Amps  
 24 = Coil Voltage  
 2 = # Of Poles

### Application Note

The contactor is the primary controller in a cooling controls circuit. It is the switching device which activates the compressor motor to pump refrigerant through the system to provide cooling.

Contactors are used to break the power supply to the compressor. Either 1 or 2 poles are needed for single phase; 2 or 3 poles for 3 phase motors. Auxiliary contacts may be used for interlock switching, fan loads or crankcase heaters. If the contactor is selected with an adequate current rating, the condenser fan may also be wired in parallel with the compressor. Then the condenser fan is energized whenever the compressor is powered.

### Checking Contactor Operation:

- Check contactor operation by switching the contactor from the system controls.
- Make sure that the pressure and overload controls can break the system circuit to prevent contactor operation, if necessary.

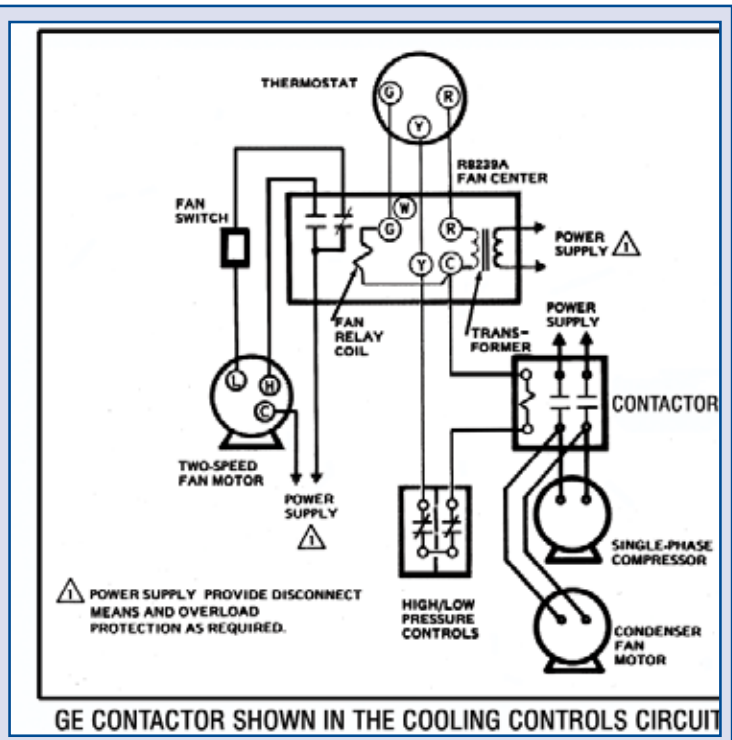

# Contactors

## Supco Brand Contactor Cross Reference

PART NO.	GE		ARROW HART	CUTLER HAMMER	DIVERSITECH	ELMWOOD	FURNAS	GE	GEMLINE	GLOBAL CUTLER HAMMER
	API	GE								
DP25241	CR453CB3HAA	***	C251NU10	C25CNB125T	***	***	45DG10AJD8A	CR353CB3AH1	***	4140
DP251201	CR453CB3AAA	***	C251NU20	C25CNB125A	***	***	45DG10AFD8A	CR353CB3AA1	***	4141
DP252401	CR453CB3BAA	***	C251NU30	C25CNB125B	***	***	45DG10AGA	CR353CB3AB1	***	4142
DP30241	CR453CC3HAA	***	C301NU10	C25CNB130T	***	***	45EG10AJA	CR353CD3AH1	***	4143
DP301201	CR453CC3AAA	***	C301NU20	C25CNB130A	***	***	45EG10AJA	CR353CD3AA1	***	4144
DP302401	CR453CC3BAA	***	C301NU30	C25CNB130B	***	***	45EG10AGA	CR353CD3AB1	***	4145
DP20242	CR453CA2HAA	***	C202U10	C25BNB220T	***	30B020	45CG20AJ	CR353CA2AH1	***	4101
DP201202	CR453CA2AAA	***	C202U20	C25BNB220A	***	30B0-20	45CG20AF	CR353CA2AA1	***	4102
DP202402	CR453CA2BAA	***	C202U30	C25BNB220B	***	***	45CG20AG	Same	***	4103
DP25242	CR453CB2HAA	***	C252U10	C25BNB225T	DP25224	30C0-20	45DG20AJ	CR353CB2AH1	***	4104
DP251202	CR453CB2AAA	***	C252U20	C25BNB225A	DP252120	30C0-20	45DG20AF	CR353CB2AA1	***	4105
DP252402	CR453CB2BAA	***	C252U30	C25BNB225B	DP252240	30C0-20	45DG20AG	CR353CB2AB1	***	4106
DP30242	CR453CC2HAA	SA2S3024V	C302U10	C25BNB230T	DP30224	30E0-20	45EG20AJ	CR353AC2AH1	***	4107
DP301202	CR453CC2AAA	SA2S30120V	C302U20	C25BNB230A	DP302120	30E0-20	45EG20AF	CR353AC2AA1	***	4108
DP302402	CR453CC2BAA	SA2S30240V	C302U30	C25BNB230B	DP302240	30E0-20	45EG20AG	CR353AC2AB1	***	4109
DP40242	CR453CE2HBB	SA2M4024V	ACC420U10	C25DNF240T	DP40224	30F0-20	45GG20AJ	CR353AD2BH1	***	4161
DP401202	CR453CE2ABB	SA2M40120V	ACC420U20	C25DNF240A	DP402120	30F0-20	45GG20AF	CR353AD2BA1	***	4162
DP402402	CR453CE2BBB	SA2M4024V	ACC420U30	C25DNF240B	DP402240	30F0-20	45GG20AG	CR353AD2BB1	***	4163
DP25243	CR453AB3HAA	***	ACC220U10	C25DND325T	***	30D0-30	42AF35AJ	CR353AB3AH1	DP2530	4110
DP251203	CR453AB3AAA	***	ACC220U20	C25DND325A	***	30D0-30	42AF35AF	CR353AB3AA1	DP2531	4111
DP252403	CR453AB3BAA	***	ACC220U30	C25DND325B	***	30D0-30	42AF35AG	CR353AB3AB1	DP2532	4112
DP30243	CR453AC3HAA	SA3S3024V	ACC330U10	C25DND330T	DP30324	30E0-30	42BF35AJ	CR353AC3AH1	DP3030	4113
DP301203	CR453AC3AAA	SA3S30120V	ACC330U20	C25DND330A	DP303120	30E0-30	42BF35AF	CR353AC3AA1	DP3031	4114
DP302403	CR453AC3BAA	SA3S30240V	ACC330U30	C25DND330B	DP303240	30E0-30	42BF35AG	CR353AC3AB1	DP3032	4115
DP40243	CR453AD3HBB	SA3M4024V	ACC430U10	C25DNF340T	DP40324	30F0-30	42CF35AJ	CR353AD3BH1	DP4030	4116
DP401203	CR453AD3ABB	SA3M40120V	ACC430U20	C25DNF340A	DP403120	30F0-30	42CF35AF	CR353AD3BA1	DP4031	4117
DP402403	CR453AD3BBB	SA3M4024V	ACC430U30	C25DNF340B	DP403240	30F0-30	42CF35AG	CR353AD3BB1	DP4032	4118
DP50243	CR353FE3BH1	SA3G5024V	ACC530U10	C25FNF350T	DP50324	30G0-30	42DF35AJ	CR353FE3BH1	DP5030	4128
DP501203	CR353FE3BA1	SA3G50120V	ACC530U20	C25FNF350A	DP503120	30G0-30	42DF35AF	CR353FE3BA1	DP5031	4129
DP502403	CR353FE3BB1	SA3G50240V	ACC530U30	C25FNF350B	DP503240	30G0-30	42DF35AG	CR353FE3BB1	DP5032	4130
DP60243	CR353FF3BH1	SA3A6024V	ACC530U10	C25FNF360T	DP60324	30H0-30	42EF35AJ	CR353FF3BH1	DP6030	4131
DP601203	CR353FF3BA1	SA3A60120V	ACC530U20	C25FNF360A	DP603120	30H0-30	42EF35AF	CR353FF3BA1	DP6031	4132
DP602403	CR353FF3BB1	SA3A60240V	ACC530U30	C25FNF360B	DP603240	30H0-30	42EF35AG	CR353FF3BB1	DP6032	4133
DP75243	CR353EG3BH1	***	ACC730U10	C25FNF375T	DP75324	***	42FE35AJ	CR353EG3BH1	***	4134
DP751203	CR353EG3BA1	***	ACC730U20	C25FNF375A	DP753120	***	42FE35AF	CR353EG3BA1	DP7531	4135
DP752403	CR353EG3BB1	***	ACC730U30	C25FNF375B	DP753240	***	42FE35AG	CR353EG3BB1	DP7532	4136
DP90243	CR353EH3BH1	***	***	C25GNF390T	DP90324	***	42GE35AJ	CR353EH3BH1	***	4137
DP901203	CR353EH3BA1	***	ACC930U20	C25GNF390A	DP903120	***	42GE35AF	CR353EH3BA1	DP9031	4138
DP902403	CR353EH3BB1	***	ACC930U30	C25GNF390B	DP903240	***	42GE35AG	CR353EH3BB1	DP9032	4139
PART NO.	HONEYWELL		JOSLYN CLARK	MA LINE POWER PRO	MARS ECONOMY	PACKARD / FASCO	PRODUCTS UNLIMITED	RBM/ESSEX	SQUARE D	STEVECO
	HONEYWELL	HONEYWELL								
DP25241	DP1025A5005	***	A77306654A3	***	***	1S25A	310015Q01XXXX	***	8910DP21	94385
DP251201	DP1025B5046	***	A77306654A1	***	***	1S25B	310015T01XXXX	***	***	94386
DP252401	DP1025C5045	***	A77306654A2	***	***	1S25C	310015U01XXXX	***	***	94387
DP30241	DP1030A5013	***	A77306653A3	***	13067/13101	1S30A	310015Q02XXXX	***	8910DP12	94388
DP301201	DP1030B5020	***	A77306653A1	***	13068	1S30B	310015T02XXXX	***	***	94389
DP302401	DP1030C5029	***	A7730665312	***	13069	1S30C	310015U02XXXX	***	***	94390
DP20242	DP2020A5021	***	A77306680A3	***	13071	2S20A	310020Q03XXXX	143-1	DP12V14	90234
DP201202	DP2020B5038	***	A77306680A1	***	13072	2S20B	310020T03XXXX	143-1	DP12V02	90235
DP202402	DP2020C5037	***	A77306680A2	***	13073	2S20C	310020U03XXXX	***	***	90236
DP25242	***	***	A77306660A3	***	13077	***	***	143-6	DP22V14	***
DP251202	***	***	A77306660A1	***	13078	***	***	143-6	DP22V02	***
DP252402	***	***	A77306660A2	***	13079	***	***	143-6	DP22V09	***
DP30242	DP2030A5004	DP2030A1003	A77306657A3	8910DP32V14	14321/13104	C2S30A	310020Q06XXXX	143-7	DP32V14	90244
DP301202	DP2030B5003	DP2030B1002	A77306657A1	***	14322	C2S30B	310020T06XXXX	143-7	DP32V02	90245
DP302402	DP2030C5002	DP2030C1001	A77306657A2	***	14323	C2S30C	310020U06XXXX	143-7	DP32V09	90246
DP40242	DP2040A5003	***	A77309045A3	8910DP42V14	14421	C2S40A	310020Q18XXXX	154-4	DP42V14	***
DP401202	DP2040B5002	***	A77309045A1	***	14422	C2S40B	310020T18XXXX	154-4	DP42V02	***
DP402402	DP2040C5001	***	A77309045A2	***	14423	C2S40C	310020U18XXXX	154-4	DP42V09	***
DP25243	DP3025A5003	DP3025A1002	A77309040A3	***	13001	3M25A	310030Q8XXXXAH	154-2	8910DPA23	90160
DP251203	DP3025B5002	DP3025B1001	A77309040A1	***	13002	3M25B	310030T8XXXXAH	154-2	DP423V02	90161
DP252403	DP3025C5001	DP3025C1000	A77309040A2	***	13003	3M25C	310030U8XXXXAH	154-2	DP423V09	90162
DP30243	DP3030A5003	DP3030A1002	A77309044A3	8910DPA33V14	14331/13007	C3M30A	310030Q9XXXXAH	154-3	DP433V14	90163
DP301203	DP3030B5002	DP3030B1001	A77309044A1	8910DPA33V02	13008	C3M30B	310030T9XXXXAH	154-3	DP433V02	90164
DP302403	DP3030C5001	DP3030C1000	A77309044A2	8910DPA33V09	13009	C3M30C	310030U9XXXXAH	154-3	DP433V09	90165
DP40243	DP3040A5002	DP3040A1001	A77309046A3	8910DPA43V14	14431/13013	C3M40A	310030Q10XXXXAH	154-4	DP443V14	90170
DP401203	DP3040B5001	DP3040B1000	A77309046A1	8910DPA43V02	13014	C3M40B	310030T10XXXXAH	154-4	DP443V02	90171
DP402403	DP3040C5000	DP3040C1009	A77309046A2	8910DPA43V09	14433/13015	C3M40C	310030U10XXXXAH	154-4	DP443V09	90172
DP50243	DP3050A5001	DP3050A1000	A77288514A3	8910DPA53V14	13200	C3L50A	310030Q16XXXXCG	***	8910M03	92459
DP501203	DP3050B5000	DP3050B1009	A77288514A1	8910DPA53V02	13201	C3L50B	310030T16XXXXCG	***	8910M03	92460
DP502403	DP3050C5009	DP3050C1008	A77288514A2	8910DPA53V09	13202	C3L50C	310030U16XXXXCG	***	8910M03	92461
DP60243	DP3060A5000	DP3060A1009	A77288517A3	8910DPA63V14	13220	C3L60A	310030Q17XXXXCG	***	8910N03	92463
DP601203	DP3060B5009	DP3060B1008	A77288517A1	8910DPA63V02	13221	C3L60B	310030T17XXXXCG	***	8910N03	92464
DP602403	DP3060C5008	DP3060C1007	A77288517A2	8910DPA63V09	13222	C3L60C	310030U17XXXXCG	***	8910N03	92465
DP75243	DP3075A5008	DP3075A1007	A77288520A3	***	13240	C3L75A	3100Y30Q75XXXXCG	***	***	92467
DP751203	DP3075B5007	DP3075B1006	A77288520A1	***	13241	C3L75B	3100Y30T75XXXXCG	***	8910P03	92468
DP752403	DP3075C5006	DP3075C1005	A77288520A2	***	13242	C3L75C	3100Y30U75XXXXCG	***	***	92469
DP90243	***	DP3090A1006	***	***	13260	C3L90A	3100Y30Q90XXXXCG	***	***	***
DP901203	***	DP3090B1005	***	***	13261	C3L90B	3100Y30T90XXXXCG	***	8910Q03	***
DP902403	***	DP3090C1004	***	***	13262	C3L90C	3100Y30U90XXXXCG	***	***	***

# Surge Protection

## Surge Arrestors



LIGHTNING is the most obvious source of a power surge, but not the only culprit. Utility Events, Cycling of Air Conditioners, Generators, and Motors can also produce damaging surges. Protect your equipment with SUPCO's Surge Arrestors. With a full product line, we can protect all of your equipment.

These devices do not protect electronic appliances such as TVs, computers, microwaves, etc. They only protect dedicated electromechanical devices such as air conditioners. If whole house protection is required use SUPCO p/n **DTK-WH5**, which will protect AC power, coaxial and two telephone lines.



SCM1



SCMPLUS

### SCM1, SCM & SCMPLUS Surge Arrestors

#### Features/Benefits

- Easy Installation at Disconnect or Panel
- Weatherproof Housing
- Indicator Light on some models for Surge Protection Present
- Promote Additional Profits
- Reduce Callbacks
- Keep Equipment Running

#### Surge Protection for:

- Air Conditioners
- Air Handlers
- Motors
- Refrigeration Systems
- Heat Pumps
- Pumps
- Furnaces
- Electro-Mechanical Devices

#### Specifications

	SCM	SCMPLUS	SCMPLUS
Service Voltage	120/240 Volt, Single Phase	120/240 Volt, Single Phase	120/240 Volt, Single Phase
Max. Surge Current	26,000 Amps	50,000 Amps	100,000 Amps
Max. Energy Dissipation	320 Joules	420 Joules	840 Joules
AC Protection Modes	L-L, L-G	L-L, L-G	L-L, L-G
Response Time	< 5ns Installed < 1ns Component Level	< 5ns Installed < 1ns Component Level	< 5ns Installed < 1ns Component Level
Operating Frequency	0 – 400 Hz.	0 – 400 Hz.	0 – 400 Hz.
Diagnostics	N/A	N/A	Indicator light – Surge Suppression Present
Class	Secondary Surge Arrestor, Cat C	Secondary Surge Arrestor, Cat C	Secondary Surge Arrestor, Cat C
Installation Point	Electrical Panel, Electrical Disconnect	Electrical Panel, Electrical Disconnect	Electrical Panel, Electrical Disconnect
Connection Method	Hardwired parallel	Hardwired parallel	Hardwired parallel
Agency Approvals	UL, cUL, ANSI/IEEE C62.11	UL, cUL, ANSI/IEEE C62.11	UL, cUL, ANSI/IEEE C62.11
Housing	High Impact Plastic	High Impact Plastic	High Impact Plastic
Housing Size	2 in. x 2 in.	4.35" x 3.55" x 1.60"	4.35" x 3.55" x 1.60"
Weight	1.0 lbs	.75 lbs	.75 lbs
Warranty	Limited Lifetime	Limited Lifetime	Limited Lifetime

#### SCMPLUS Operation:

The SCMPLUS uses an LED diagnostics connected at each phase wire to indicate power, ground and surge protection activity.

#### LED Sequence:

- 1 LED = 120 VAC L-G operation
- 2 LED = 240 VAC L-L operation

#### Wiring The Surge Protector:

The SCM1, SCM and SCMPLUS include two black wires and one green wire. A surge protector works by shunting the voltage to ground. A good ground is imperative. The National Electrical Code (NEC) maximum resistance at ground is 25 ohms.

#### 120 VOLT WIRING

- Black to Hot
- Black to Neutral
- Green to Ground

#### 240 VOLT WIRING

- Black to Hot
- Black to Hot
- Green to Ground

**\* For Installation Instructions See Page 128**

#### HVAC Installation Points

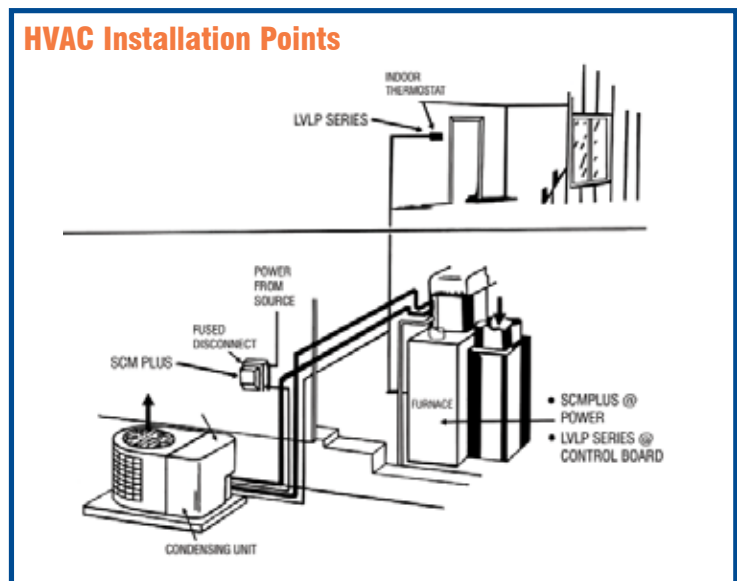

Refer to and abide by all Local and State Electrical Codes for proper installation of these devices.

# Surge Protection



DTK-240-3CMPLUS

## DTK-240-3CMPLUS 3 Phase Surge Arrestors

- 240 volt three phase
- 50,000 amp surge current, per phase
- Limited lifetime warranty

### Air Conditioning & Heat Pump Surge Protection Applications

EQUIPMENT SIZE	TRANSIENT POTENTIAL	PART NO.
Up to 5 Tons	Low to Moderate (Degraded arc fault Potential)	SCMPLUS DTK-3CM Series

\*Note: These items are special order. Please call SUPCO for more information (800) 333-9125

### Specifications

	DTK-240-3CMPLUS
Service Voltage	240 VAC 3 phase
Max. Surge Current	50,000 Amps
Continuous Current	Unlimited
Max. Energy Dissipation	660 Joules
MCOV	250 VAC (L-G)
AC Protection Modes	L-L, L-G
Response Time	< 5ns Installed, < 1ns Component Level
Operating Frequency	0-400 Hz
Class	Secondary Surge Arrestor, Cat C
Installation Point	Meter base, main panel, disconnect or weatherhead
Connection Method	Hardwired parallel
Agency Approvals	UL-OWHX, cUL, ANSI/IEEE C62.11
Housing	High Impact Plastic
Housing Size	4.35" x 3.35" x 1.60"
Weight	0.75 lbs
Warranty	Limited Lifetime



## DTK-LVLP Series

### Low Voltage Applications

- Available in 4 pairs
- UL497B listed and UL497A models available
- Specify desired clamping voltage; 7, 15, 27, 52, 75, 95, 130
- Hardwire Series Connection

\*Note: these units are only examples of the many applications. Voltages may vary between different manufacturers. Please call SUPCO Technical Support Representative for specific applications.

**\*Any other DTK Surge Arrestor Available by Special Order.**

PART NO.	# OF WIRES PROTECTED	130 VRMS	95 VRMS	75 VRMS	52 VRMS	27 VRMS	15 VRMS	7 VRMS
DTK-4LVLP	8 wires	RUV	SGR	SPK	OPX	LV	X	D

Example: DTK-1LVLP-SCP\*-LV (30V DC, 2 wire) \*Note: SCP adds over current protection.

### RESIDENTIAL APPLICATIONS

DTK-1LVLP-LV (24V AC) Load side of 24v AC transformer

DTK-1LVLP-D (5V DC) Thermostat lines, controls, sensors

### COMMERCIAL APPLICATIONS

DTK-2 LVLP-SCP-RUV (130V DC) Telephone lines at master/control Communications Panel

DTK-1-4 LVLP-LV (24V AC/DC) (SCP available) 4-20 milliamp loop circuits for monitoring pressure, humidity, air quality, air flow...

DTK-1-4 LVLP-D (7V DC) Communication circuits, RS485 Networks, temperature, air and liquid monitoring controls



## SCMPLUG

Providing the same protection of the SCM in a convenient, single outlet plug. Plug the SCMPLUG into an outlet, then plug your sensitive equipment into the SCMPLUG for surge protection!



## APP120 All Purpose Protector

### Benefits

- Helps prevent blown fuses
- Short cycle protection
- Prevents operation in low voltage conditions
- Prevents false starting attempts
- Easy installation
- LED to indicate proper operation
- Automatically restarts

Helps protect refrigerators, window air conditioners, dehumidifiers and other appliances from damage due to power interruptions. (Brown-outs)

**Refer to and abide by all Local and State Electrical Codes for proper installation of these devices.**

### Specifications

	APP120
Minimum Starting Volts	90 VAC single phase
Operating Volts	115 VAC single phase
Maximum Switching	1.0 HP @ 115 VAC (12,000 BTU)

### General Specifications

Time Delay	4 minutes ±1 minute
Power consumption	10 mA
Operating Temperature	14°F to 158°F (-10°C to 70°C)
Size	9.055" X 4.72" X 3.15" (230mm X 120mm X 80mm)

# Motor Protection

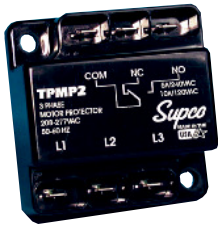

## TPMP2

### Compact Three Phase Motor Protector

#### Features & Benefits

- Low cost three phase motor protection
- Easy Installation
- Compact design
- Monitors and protects against phase loss and phase imbalance only
- Operating Temperature -40°F to +167°F (-40°C to +75°C)
- 1/4" male spade terminal connections

#### Sequence of Operation

The TPMP series will disconnect the motor pilot when the monitored problem is detected. The TPMP series will only re-energize the circuit when all 3 phases are activated at the full voltage ratings and the delay on make time has elapsed. The TPMP2 does not have a time delay feature.

#### Applications

- HVAC/R Motors and Pumps
- HVAC/R Compressors
- Protects Scroll and Screw Compressors from reverse rotation
- Material Handling Equipment (Overhead Electric Crane Motors)
- Elevator Motors
- Utilities

#### TPMP2

Input Line Voltage	208 - 277 VAC
Control Voltage	18 - 240 VAC
Frequency	50/60 Hz
Imbalance	Fixed 7%
Total Power Consumption	3 VA Maximum
Contact Type	N.O. & N.C. Type C
Resistive	5 AMP 240 VAC/10 AMP 120 VAC
Fire Resistive Plastic	UL-94 VO
Dimensions	2.35" x 2.43" x 1.1" (59.7 x 61.7 x 27.9 mm)
Weight	2 oz. (54 gr)



## TPMPU

### Universal Three Phase Motor Protector

#### Features & Benefits

- Low cost Universal three phase motor protection
- Easy Installation
- Minimizes inventory
- Monitors and protects against phase loss, reversal and imbalance
- Response time 80 milliseconds maximum
- Bright LED for on and fault indications
- Operating Temperature -40°F to 167°F (-40°C to 75°C)
- 1/4" male spade terminal connections
- Delay on make timer
- Adjustable 10 seconds to 5 minutes
- Tolerance +/- 20%

#### TPMPU

Input Line Voltage	180 - 600 VAC
Control Voltage	18 - 240 VAC
Frequency	50/60 Hz (cut wire for Hz)
Imbalance	Adjustable $\pm 40$ to 20%
Total Power Consumption	3 VA Maximum
Contact Ratings	10 AMP SPDT
Resistive	10 AMP 240 VAC, 12 AMP 120 VAC/24 VAC
Inductive	4.5 AMP 230 V- Cos. 0 0.6
Fire Resistive Plastic	UL-94 VO
Dimensions	5.35" x 3.68" x 1.26" (136 x 93.5 x 32 mm)
Weight	6.35 oz. (180 gr)

#### TPMPU Application Note

The TPMPU is designed to protect the motor against running with phases reversed. On your first start if the fault indication is ON and the motor did not start, switch any two of the lines (L1, L2, or L3) so that the TPMPU phases match the existing motor

## Three Phase Motor Protector Tech Tip

### Voltage Imbalance

The voltage applied to a three-phase motor must be balanced, meaning the applied voltage to each leg must be relatively the same. The applied voltage must not deviate more than 2% from the average supplied voltage. A voltage imbalance of greater than 2% will cause the windings within a motor to generate heat beyond its safe levels, leading to premature motor failure.

The following steps can be used to calculate the percentage of voltage imbalance:

1. Measure the voltage applied across each of the windings, from L1 to L2, L1 to L3 and L2 to L3.
2. Next, calculate the average supplied voltage. This is done by adding the three measured voltage values and dividing the sum by three.
3. Next calculate the maximum deviation of each of the measured voltages from the calculated average voltage.
4. The percentage of voltage imbalance can then be calculated using the following formula:

$$\% \text{ Voltage Imbalance} = \text{Maximum Deviation} / \text{Average Voltage} \times 100$$

For example, suppose the following voltages were measured:

L1 to L2 - 221 volts  
L2 to L3 - 223 volts  
L1 to L3 - 220 volts

Calculate the average applied voltage:

221 volts + 223 volts + 220 volts = 664 volts/3 = 221.3 volts  
(average applied voltage)

Calculate the maximum deviation of each applied voltage from the calculated average voltage:

221.3 - 221 = 0.3 volts  
223 - 221.3 = 1.7 volts  
221.3 - 220 = 1.3 volts

1.7 volts is the maximum deviation from the average calculated voltage.

Calculate the percentage of voltage imbalance:

$$\% \text{ Voltage Imbalance} = \text{Maximum Deviation} / \text{Average Voltage} \times 100$$

$$\% \text{ Voltage Imbalance} = 1.7 \text{ volts} / 221.3 \text{ volts} \times 100 = 0.77\%$$

Since this is well below 2%, the motor will operate safely.



## SUPCO Commercial Refrigeration Defrost Controls

Designed to meet a wide variety of customer requirements. These electro-mechanical controls are used on many different types of commercial refrigeration equipment, including walk in boxes, reach in boxes, refrigerated cases and condensing units.



### Features/Benefits

- Heavy-duty synchronous motor.
- Adjustable Defrost Initiation Frequency: One to six times per day.
- Adjustable Defrost Cycle Duration: 4 to 110 minutes in two-minute increments.
- Contact Arrangements: Electric heat, hot gas, or off cycle defrost available.
- Heavy-duty steel case with electrical knockouts in the sides, back and bottom.

### Specifications

- Operating Voltages: 120 or 208/240 VAC, 60 Hz
- Amperage: 40-amp non-inductive @ 120, 208 or 240 VAC
- Maximum hp: 2 hp @ 120, 208 or 240 VAC
- Pilot Duty: 690 VA @ 120, 208 or 240 VAC
- Operating Temperature Range: -35°F to 175°F
- Overall Case Dimensions: 7.697" H x 4.4" W x 3.8" D
- Shipping Weight: S8040 series 3.5 lbs & S8141 series 3.75 lbs.

### Applications

As a defrost control based upon the following functions.

- Time initiation and time termination.
- Time initiation and temperature termination.
- Time initiation and pressure termination.



### Accessories

X3596 Dial Pins 5 Pins Per Pack

### Models

PART NO.	VOLTAGE	SWITCHING		TIME INITIATED	TIME INITIATED
		NO NORMALLY OPEN	NC NORMALLY CLOSED	TIME TERMINATED	TEMPERATURE OR PRESSURE TERMINATED
S804100	120	1 NO / 2 NC		YES	NO
S804120	240	1 NO / 2 NC		YES	NO
S804500	120	1 NO / 1 NC		YES	NO
S804520	240	1 NO / 1 NC		YES	NO
S814100	120	1 NO / 2 NC		NO	YES
S814120	240	1 NO / 2 NC		NO	YES
S814500	120	1 NO / 1 NC		NO	YES
S814520	240	1 NO / 1 NC		NO	YES

### Cross Reference

SUPCO	PARAGON	PRECISION
S804100	8041-00	6041-00
S804120	8041-20	6041-20
S804500	8045-00	6045-00
S804520	8045-20	6045-20
S814100	8141-00	6141-00
S814120	8141-20	6141-20
S814500	8145-00	6145-00
S814520	8145-20	6145-20

## M814520

EXACT DROP-IN REPLACEMENT MECHANISM for SUPCO S814520 and Paragon® 8145-20



Sold in convenient  
6-pack counter display!

For Wiring Diagrams See Page 129

# Timers

## General Purpose 24 Hour Mechanical Type



### CD100 Series



CD101

#### Features

- Dial: 24 hour, 2 on and 2 off trippers
- Switch Rating: 40 amps resistive or tungsten, 1000 VA pilot duty, 2 hp and 120 or 240 volts.
- Operations: Up to 10 ON/OFF operations per 24 hours. With manual ON/OFF switch that allows circuit to be hand operated without disturbing scheduled setting.
- Minimum Setting: 1 hour between ON/OFF, 2 hours between OFF/ON.
- Enclosure: Non corrosive NEMA 1

#### Applications

- Pool filter pumps
- Indoor and outdoor lighting systems
- Pool heaters
- Sprinkler systems

PART NO.	REPLACES			
	PARAGON	VOLTS	SWITCH	ENCLOSURE
CD101	4001-00	120	SPST	NEMA1
CD104	4004-71	240	DPST	NEMA1

#### Accessories

X100 - Trippers (2 per bag)

## 5000 Series Multi Circuit Defrost Controls



These accurate multi-circuit timing devices can individually operate from 1 to 24 switches.



#### Features

- Field adjustable defrost control combines ease of programming with accuracy and reliability.
- Positive snap acting switches to provide positive and immediate switching.
- Time Cycle: Adjustable in 2 minute increments from 2 to 120 minutes.
- Motor: Synchronous type, completely sealed and lubricated.
- Motor Power: 4 watts
- Motor Temperature Range: (Ambient): 35°F to 175°F
- Base: All steel construction, 16 gauge-channelled steel. Zinc plated for corrosion resistance and durability.
- Contact Transfers: Maximum number of contact transfers per 24-hour period for each program timer is 64 (8-switch unit) or 32 (4-switch unit).
- Terminals: 1/4" male quick connect (standard).

PART NO.	VOLTS	Hz	NO. OF SWITCHES	NO. OF MOTORS
50100B	120	60	8	2
50103B	240	60	8	2
5011	Slave	Slave	8	Slave
5014	Slave	Slave	4	Slave
50150B	120	60	4	2
50153B	240	60	4	2

#### Applications

The 5000 series controls are designed to control a series of operations with a variable time sequence; such as a refrigerator defrost cycle.

## Electronic Adjustable Timers



#### Features

- Adjustable Interval Timers
- LED to indicate energized load
- Fast cycle button to alternate timer manually
- Automatic cycle is between 40 to 60 seconds
- Timer reset connection for external reset control
- Replaces most mechanical commercial timers
- Mounted using # 6 screws (not included)
- Available in 120 Volts or 220 Volts

#### Common Specifications for EDT12 and EDT13

On Time	5 to 60 Minutes
Off Time	1 to 27 Hours
Timing Accuracy	±10%
Fast Cycle	Approximately 30 Seconds

#### Applications

- Defrost Heaters
- Motors
- Water Heaters
- Pumps
- Indoor or Outdoor Lighting Systems

PART NO.	OPERATING VOLTAGE	MAXIMUM MOTOR SWITCHING CAPACITY, hp	MAXIMUM SWITCHING CURRENT (RESISTIVE), AMP	NO. OF Set OF CONTACTS
EDT12	120	1	27	1
EDT12-20	220	2	25	1
EDT13	120	1	27	2
EDT13-20	220	2	25	2

## EDT Series Electronic Adjustable Defrost Timers



#### Features/Benefits

- Universal Replacement
- Electronic Circuitry
- Adjustable Defrost Frequency 4 to 12 Hours
- Adjustable Defrost Time 10 to 35 Minutes
- Available in 115 & 208/240 Volts
- Standard Size & Mounting To Fit Most Applications
- No Ground Wire
- Quiet Operation & Durability
- Standard Terminal Configuration To Accommodate Most Connections
- Dust Proof Case
- Temperature Range: 32°F to 135°F (0°C to 57°C)
- Humidity Range: 10-95% Non-Condensing

PART NO.	VOLTAGE	MAX. COMPRESSOR RATING	MAX. RESISTIVE LOAD
EDT10	115 VAC	1/3 HP	10 Amp
EDT20	208/240 VAC	1/3 HP	5 Amp
EDT11	115 VAC	3/4 HP	20 Amp
EDT21	208/240 VAC	3/4 HP	20 Amp

#### Optional Accessories

- WH3 - Three wire adapter kit
- WH4 - Four wire adapter kit

# Cold Controls

## GC400 Series Cycle Defrost Controls

Constant Cut-in Universal Replacement

### Features/Benefits

- 39°F Constant Cut-In
- Adjustable Cut Out
- Universal Mounting Hardware Included

### Applications

- Provides automatic defrost each compressor cycle



PART NO.	CALIBRATION °F			CAPILLARY	
	NORM OFF	WARM OFF	COLD OFF	CUT-IN	LENGTH
GC401	3	-11	-23	39	51"
GC405	12	-5	-15	39	60"
GC410	12	24	5	39	40"

Thermostats rated 125 VAC, 1/2 HP, 20 Amps F.L - 80 Amps L.R., SPST switch action.

## GC500 Series Cold Control

Constant Differential Universal Replacement

### Features/Benefits

- Maintains Differential between On and Off Temperatures
- Adjustable Operating Temperatures
- Universal Mounting Hardware Included

### Applications

- "Frostfree" and Conventional Refrigeration Units



PART NO.	NORMAL °F		CALIBRATION °F		DIFF °F	CAPILLARY LENGTH
	OFF	ON	WARM OFF	COLD ON		
GC501	9	20	38	-16	11	42"
GC503	9	26	42.5	-16	17	42"
GC505	31	36	49	16	5	24"
GC506	18	31	48.5	-7	13	24"

Thermostats rated 125 VAC, 1/2 HP, 20 Amps F.L - 80 Amps L.R., SPST switch action.

## GC600 Series Cold Control

Constant Differential Universal Replacement

### Features/Benefits

- Maintains Differential between On and Off Temperatures
- Adjustable Operating Temperatures
- Universal Mounting Hardware Included

### Applications

- Freezers



PART NO.	NORMAL °F		CALIBRATION °F		DIFF °F	CAPILLARY LENGTH
	OFF	ON	WARM OFF	COLD ON		
GC601	-5	4	22	-29	9	78"
GC602	-13	0	12	-30	13	78"
GC604	-12	6	20	-34	18	36"
GC607	-8	1	13	-23	9	31"

Thermostats rated 125 VAC, 1/2 HP, 20 Amps F.L - 80 Amps L.R., SPST switch action.

## GC700 Series For Air Conditioners

Universal Replacement

### Features/Benefits

- Covers a Wide Range of Applications
- Universal Mounting Hardware Included

### Applications

- Room Air Conditioners



PART NO.	RANGE °F			CAPILLARY DETAILS		ELECTRICAL RATINGS		
	COLD Off	WARM On	DIFF °F	LENGTH	STYLE	120 / 208 / 240 VAC SWITCH	F.I.A.L.	R.A
GC701	52	93	6	18"	Air Coil	SPST	20 A	80 A
GC702	52	93	6	36"	Straight	SPST	30 A	125A
GC707	52	93	6	36"		StraightSPDT		25A

80A

## SC1002 Temporary Cold Control

### Features/Benefits

- Temporary Emergency Universal Replacement
- Keeps Equipment Up & Running Until Exact Replacement or Permanent Control Is Installed
- SC1002 Can Be Used As Permanent Control
- Three Mounting Options Available Suction Cup, Velcro or Screw Mounting
- Safe & Easy Installation

### Applications

- Domestic & Commercial Refrigerators & Freezers



PART NO.	TEMP. RANGE	DIFF °F	SWITCH
SC1002	-6°F to 40°F	7°	SPST

\*For wiring accessories refer to pages 107 -110 Terminals & Connectors.

# Time Delays

## TD Series Time Delays

### Standard Features / Specifications

- Three styles available: Delay on Make, Delay on Break & By – Pass
- Fixed or adjustable delay ranges
- Initiate timer in 70 milliseconds
- Broad input voltage range (Pilot Circuit)  
19 to 250 VAC/VDC, 50/60 Hz (TD60)  
19 to 250 VAC ONLY, 50/60 Hz (TD70)
- Maximum load 1.0 amp, 10 amp inrush
- Varying models work with or without anticipator type thermostats
- Terminal or wire connections available

- Operating Temperature Range 0°F to 160° F (-18°C to 71°C)
- Compact Size 2" x 2" x .075" (5.08 x 5.08 x 1.9 cm)
- Non positional single hole mounting
- All parameters are subject to change as per special requirements
- By – pass a control or device during start up
- Helps to reduce power surges in multiple compressor applications

### General Applications

- Protection from short cycling of compressor
- Ideal for compressor staging



## TD60 Series Delay on Make Timers (DOM)

### Mode of Operation

- Upon application of power the time delay initiates. On completion of selected delay period, the load is energized. Timer will reset on power interruption or when thermostat disconnects.

### Timing Diagram

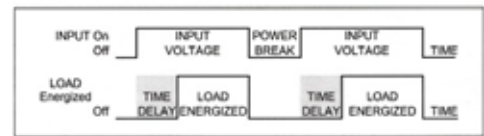

PART NO.	DELAY RANGE ADJUSTABLE	DELAY RANGE FIXED (min)	CONNECTIONS	REPLACES
TD68**	6 sec to 8 min	n/a	2 1/4" male terminals	Diversitech AC-800-ADM1 / ICM 105 / A-1 706 / Mars 32391
TD69*	6 sec to 8 min	n/a	2 1/4" male terminals	Diversitech AC-800-ADM1 / ICM 102 / A-1 701 / Mars 32391
TD69W*	6 sec to 8 min	n/a	2 6" long wire leads	

\*Cut the jumper to use in 120/240 volts. \*\*The TD68 is not for use with a cooling anticipator.



## TD70 Series Delay on Break Timers (DOB)

### Mode of Operation

- Upon application of power the load is energized immediately. When the thermostat opens or on power interruption the load is de-energized and the time delay initiates. The load will be energized again after the delay time has elapsed.

### Timing Diagram

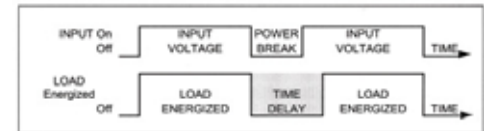

PART NO.	DELAY RANGE ADJUSTABLE	DELAY RANGE FIXED (min)	CONNECTIONS	REPLACES
TD72**	6 sec to 5 min	n/a	2 1/4" male terminals	Diversitech ASC500-ADB1 / ICM203 / Mars 32392 / A-1 EAC-501-ADJ
TD73*	6 sec to 5 min	n/a	2 1/4" male terminals	Diversitech ASC500-ADB1 / ICM203 / Mars 32392 / A-1 EAC-501-ADJ
TD73W*	6 sec to 5 min	n/a	2 6" long wire leads	

\*Cut the jumper to use in 120/240 volts. \*\*The TD72 is not for use with a cooling anticipator.

## Ventilator Motors



### SM550 Series Ventilator Motors

#### Features/Benefits

- Exact Replacement for Nutone Range Hood Ventilators
- C Frame Design
- SM550 Motor includes FB460 Impeller

#### Applications

- Range Hoods
- Bathroom Exhaust Fans

PART NO.	SPEED	RPM	SHAFT DIMENSIONS	ROTATION	STACK	LEAD	NUTONE NO.	ROBERTSHAW NO.
SM550	1	3000	7/32" X 1 3/4"	CCW	1/2"	120 V Plug	C65878	33-100
SM551	2	High 3000 Low 1640	7/32" X 1 7/16"	CW	7/8"	2 Speed Plug	C52367	33-101
SM552	1	3000	7/32" X 1 1/4"	CCW	3/4"	120 V Plug	C63675	33-103
SM553	1	3000	7/32" X 1 3/4"	CCW	3/4"	Eyelet	C66582	33-104
SM554	2	High 3300 Low 1500	7/32" X 1 7/16"	CCW	7/8"	2 Speed Plug	C27987	33-105
SM555	1	3000	7/32" X 2 3/8"	CCW	5/8"	120 V Plug	C68627	33-106
SM556	1	3000	7/32" X 1 7/8"	CCW	5/8"	120 V Plug	C34484	N/A

### SM700 Series Ventilator Motors

#### Features/Benefits

- Exact Replacement for Broan Ventilators
- C Frame Design
- 120 Volts / 60 Hz
- CCW Rotation
- Multi Fit To Work With Other Brand Ventilators

PART NO.	SPEED	SHAFT DIA.	SHAFT STACK	SHAFT LENGTH	PLUG TYPE	REPLACES BROAN NO.
SM700	2	7/32"	3/4"	1 1/4" F	3 PIN	99080218
SM701	1	1/4"	7/8"	2 3/4" F	2 PRONG	99080159
SM702	1	1/4"	7/8"	2 3/4" F	5 PIN	99080160
SM703	1	5/32"	1/2"	1 3/4" S	2 PRONG	99080245
SM704	1	7/32"	7/8"	1 1/4" F	2 PRONG	99080166
SM705	1	.181"	5/8"	1 1/2" F	2 PRONG	99080216

#### Tech Tips

- "F" suffix on shaft length indicates flat on shaft.
- "S" suffix indicates spline shaft.
- When replacing a motor make sure that the type, voltage, amperage, wattage, rotation, shaft size, stack size and the electrical connectors are the same as the original motor.



## Evaporator Fan Motors



### SM999 Universal Evaporator Fan Motor Kit – 120 VAC

#### Features/Benefits

- Prefastened Multi Fit, Break Off Mounting Bracket
- Break Off 2" Motor Shaft with Breakaways at 1/2" and 1-1/2"
- Includes All Mounting Accessories and Hardware
- Reversible Rotation
- Single Speed
- Shaft Diameter 1/8"

#### Applications

- Replaces Over 450 Different Evaporator Type Motors.
- Direct Replacement For The GEM 240 Series, Mars 90999 and Robertshaw 33-110, 33-112 & 33-114.

### SM998 Universal Evaporator Fan Motor Kit – 220 VAC

#### Features/Benefits

- Includes the same Features & Benefits, Applications and Specifications as the SM999, except it operates on 220 VAC 50/60 Hz.
- Direct Replacement for the Mars 90998

PART NO.	DESCRIPTION
SM999	120 VAC, 3000 RPM, 1/200 hp, .31 AMP impedance protected
SM998	220 VAC, 3000 RPM, 1/200 hp, .31 AMP impedance protected



### Motor Rotation

To determine motor rotation:

CW - Clockwise CCW - Counter Clockwise

A. Facing shaft end of motor, locate the copper Buss Bar as indicated in illustration.

B. The Buss Bar location determines shaft rotation.

### Motor Rotation as viewed facing Shaft

CW - Clockwise Rotation

CCW - Counter Clockwise

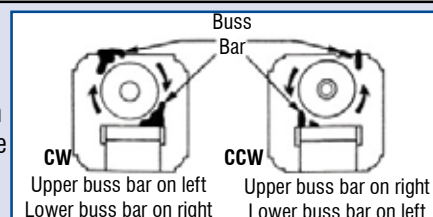

# Motors



## SM140-40A Blower Fan Assembly

### Features/Benefits

- Direct replacement kit for Nutone bath fans
- Replaces Nutone motor P/N K5895 and kit P/N K5894

- Kit includes single speed motor, 3 3/4"x2" blower wheel and mounting bracket.
- Motor includes 6" wire leads with molded plug.

PART NO.	SPEED	RPM	VOLTS	AMPS	ROTATION	NUTONE
SM140-40A	1	2400	115	0.9	CCWSE	K5894 Motor Kit K5895 Motor Only

## Exact Replacement & Utility Motors



## SM600 Series Utility Motor Kits

### Features/Benefits

- Versatile replacement for all "C" Frame and 3 1/2" Round Style motors
- Impedance Protected
- SM670, SM672 and SM673 include fan blades FB402 and FB550
- SM675 is thermal protected
- Available in sleeve or ballbearing design
- SM675 includes fan blade FB550 only
- Motor Kits include complete hardware and mounting kits

### Applications

- Reach In Cooler & Freezer Evaporators
- Walk In Cooler & Freezer Evaporators
- Exhaust Fans
- Ventilator Fans
- Range Hoods
- Electric Unit Heaters

### Specifications

PART NO.	TYPE	VOLTS AC	RPM	CURRENT (AMPS)	SHAFT DIMENSIONS	STACK SIZE	ROTATION (REVERSIBLE)	ACME MIAMI	REPLACES BOHN	REPLACES ROBERTSHAW	REPLACES MARS
SM670 <sup>a</sup>	Sleeve	120	3000	0.55	3/16" X 1-1/4"	5/8"	CW/CCW	600, 700, 710, 4670		14001	90971
SM671	Sleeve	120	3000	0.55	3/16" X 1 1/4"	5/8"	CW/CCW			14003	
SM672 <sup>a</sup>	Sleeve	240	3000	0.32	3/16" X 1 1/4"	5/8"	CW/CCW	602, 702, 4672		14005	90982
SM673 <sup>a</sup>	Sleeve	120	3000/1550	.55/.34	3/16" X 1 1/4"	5/8"	CW/CCW	4673		14007	
SM675 <sup>b</sup>	Sleeve	120/240	3000	1.0/.50	3/16" X 2 3/8"	1"	CW/CCW	7502		90970	
SM676	Sleeve	120	3000	0.5	3/16" X 1 1/4"	7/8"	CW/CCW	780		14011	
SM678	Sleeve	120	3000	0.55	3/16" X 1 1/2"	1/2"	CW/CCW			14015	
SM679	Sleeve	120	3000	0.5	7/32" X 1 1/2"	5/8"	CW/CCW			14017	
SM680	Sleeve	120	3000	0.9	3/16" X 1 1/2"	1 1/8"	CW/CCW	750		14019	90970
SM681	Sleeve	120	3000/1550	.82/.21	3/16" X 1 3/8"	5/8"	CW/CCW			14021	
SM683	Sleeve	240	3000	0.25	3/16" X 1 1/4"	7/8"	CW/CCW			14025	90970
SM684	Sleeve	120	3000/1550	.82/.21	7/32" X 2 1/4"	1"	CW/CCW				
SM685	Sleeve	120	3000/1550	.82/.21	3/16" X 1 3/4"	7/8"	CW				
SM690C	Sleeve	120	3000	0.4	3/16" X 1 1/2"	5/8"	CW				
SM691	Sleeve	120	3000	.80	3/16" X 1 1/4"	5/8"	CW		5007S 5036F 5018S		
SM692	Sleeve	240	3000	.40	3/16" X 1-1/4"	5/8"	CW		5007T 5018T		
SM775	Sleeve	120/240	3000	1.0/.52	3/16" X 2-3/8"	1"	CW/CCW				

<sup>a</sup> Includes hardware kit: 2 fan blades, mounting bracket, hub adapter, 1/4" shaft adapter, & 5/16" shaft adapter.

<sup>b</sup> Includes hardware kit: 1 fan blade, mounting bracket, hub adapter, 1/4" shaft adapter, & 5/16" shaft adapter. Motor shaft is 2 3/8" with breakoffs at 5/8" & 1 7/8" points.



## SM6700B Motor Kit Assembly

### Features/Benefits

- Replaces Acme Miami 700
- OEM replacement for Bohn, Heatcraft, Uppco, Singer, GE 33 Series.
- Kit includes reversible motor, three fan blades, hardware kit and Instructions.

### Applications

- Commercial Refrigeration Evaporators

### Specifications

VOLTS	HERTZ	AMPS	RPM	SHAFT SIZE	STACK SIZE	BEARING TYPE
120	60	.55	3000	3/16" x 1 1/4"	5/8"	Sleeve

### SM6700B

#### Replacement Fan Blades 3/16" Hub

FB402	4", CW, 5 wing
FB455 (Bohn 5101B)	5 9/16", CCW, 5 wing
FB550	5 1/2", CCW, 4 wing

## Motor Accessories



## GFK1 Grease Fitting Kit

- One time installation
- Provide easy access at hard to reach lubrication points
- Makes preventative maintenance (PM's) routine
- Eliminates need for cover removal and equipment disassembly
- Complete with 10' high pressure tubing and required fittings
- Tubing rated -60°F to 200°F

## HVAC - Duct Boosters



Conforms to UL Standard 507



## DB Series Duct Boosters

For increased Air Flow in both hot and cold forced air systems, the DB Series Duct Boosters provide the easy, economical solution.

### Features/Benefits

- Easy installation
- Energy savings
- Economical solution
- Fits in round, square or rectangular ducts
- Operates only when you want it
- 1 year warranty
- Motor is thermally protected
- Maximum operating temperature: 140°F (60°C)
- Maximum airstream temperature: 135°F (58°C)
- Motor thermal fuse: 150°F (64°C)

### Applications

- Problem heating and cooling areas
- Low air flow areas

### Installation Tools Required

- Screwdriver
- 1/2" and 1/8" sheet metal drill bits
- Sheet metal shears
- Electrical junction box (if required by code)

PART NO.	DIMENSIONS	FAN BLADE	VOLTAGE	MOTOR RATINGS	CFM
DB6	6" x 6"	5.25", 1950 rpm	115V 60Hz	.35 A, 30 Watts	250
DB6-220	6" x 6"	5.25", 1950 rpm	220V 50Hz	.25 A, 30 Watts	250
DB8	8" x 8"	7", 1750 rpm	115V 60 Hz	.75 A, 60 Watts	500
DB8-220	8" x 8"	7", 1750 rpm	220V 50 Hz	.45 A, 60 Watts	500
DB10	8" x 10"	8", 1300 rpm	115V 60 Hz	1.5 A, 120 Watts	650
DB12	9" x 12"	10", 1300 rpm	115V60 Hz	1.5 A, 120 Watts	800

Mounting Kit and Templates included.



Use the SUPCO DAVM+ to check duct operation and efficiency. Refer to page 78 for complete details.

# Fan Blades



## Exact Replacement Plastic Impellers

### Features/Benefits

- Broan & Nutone Exact Replacement Impellers
- 3 Sizes Available

### Tech Tip

- "F" Suffix on impeller hole indicates impeller will accommodate flat shaft.

### Applications

- Bathroom Ventilators
- Kitchen Ventilators

PART NO.	REPLACES MFG. NO.	BLADE O.D.	HOLE I.D.
SB001	Nutone 68920	4 5/8"	.181F
FB460	Broan 9910379H	4 9/16"	.218
FB461	Broan 99110630	4 5/8"	.150



## Plastic Blower Wheels

### Features/Benefits

- 3 Sizes Available

### Applications

- Bathroom Ventilators
- Kitchen Ventilators

PART NO.	SHAFT	ROTATION	DIAMETER	BOTTOM DEPTH	TOP DIAMETER	OEM PART NO.
FB250	1/8"	CW	2 1/2"	1"	2 11/16"	
FB325	3/16"	CW	3"	1"	3 1/4"	
FB590	1/4"	CW	5 3/4"	2"	6 1/8"	Nutone 59000A



## Plastic Vent Hood Fan Blades

### Features/Benefits

- 2 Sizes Available

### Applications

- Ducted & Non Ducted Vent Hoods

PART NO.	SHAFT	DIAMETER	NO. BLADES	ROTATION	PITCH	Volume
FB660	7/32"	6 5/8"	5	CW	25°	High
FB665	7/32"	6 5/8"	5	CW	12°	Standard

Use with SM500 series or SM700 series that have 7/32" w/flat shaft.  
Replaces Nutone 68929300 and many Broan blades.

## Plastic Fan Blades – General Purpose

### Features/Benefits

- Celcon Plastic Construction
- Light Weight Design Reduces Bearing Wear & Vibrations
- 2 1/2" to 8" Diameter Sizes Available (1/2" increments)
- Integral Hub Available In 1/8", 3/16", 1/4" & 5/16" Sizes
- Color Coded Rotation White = CW Gray = CCW
- Eliminates Bent or Misaligned Blades
- Low Air Noise

### Applications

- Refrigerator & Freezer Evaporators
- Ventilators



PART NO.	SHAFT	DIAMETER	NO. OF BLADES	ROTATION
FB302	3/16"	3 1/2"	4	CW
FB350	3/16"	3 1/2"	4	CW
FB401	1/8"	4"	5	CW
FB402	3/16"	4"	5	CW
FB403	1/8"	4"	5	CCW
FB404	3/16"	4"	5	CCW
FB501	3/16"	5"	5	CW
FB504	3/16"	5"	5	CCW
FB550	3/16"	5 1/2"	4	CCW

PART NO.	SHAFT	DIAMETER	NO. OF BLADES	ROTATION
FB551	1/4"	5 1/2"	4	CCW
FB601	3/16"	6"	6	CW
FB604	3/16"	6"	4	CCW
FB650	3/16"	6 1/2"	5	CW
FB651	1/4"	6 1/2"	5	CW
FB701	1/4"	7"	5	CW
FB702	5/16"	7"	5	CW
FB703	1/4"	7"	5	CCW
FB803	1/4"	8"	5	CCW

# Fan Blades

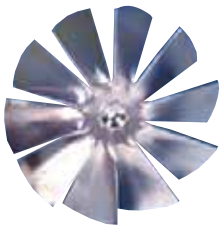

## Aluminum Fan Blades - General Purpose

### Features/Benefits

- 22 Gauge Aluminum Alloy Construction
- Light Weight Design Reduces Bearing Wear & Vibration
- 4" to 6 1/2" Diameter Sizes Available (1/2" increments)
- Slotted Set Screw Hub Sizes 3/16", 7/32" & 1/4"
- Clockwise or Counter Clockwise Rotations

### Applications

- Refrigerator & Freezer Evaporators
- Ventilators

### Tech Tip

- Rotation is determined by facing air discharge

PART NO.	SHAFT	DIAMETER	NO. BLADES	ROTATION	PITCH
FB152	3/16"	4"	10	CCW	35
FB153	1/4"	4"	10	CCW	35
FB156	3/16"	4 1/2"	10	CW	40
FB157	1/4"	4 1/2"	10	CW	40
FB158	3/16"	4 1/2"	10	CCW	40
FB159	1/4"	4 1/2"	10	CCW	40
FB162	3/16"	5"	4	CW	19
FB163	7/32"	5"	4	CW	19
FB164	1/4"	5"	4	CW	19
FB165	3/16"	5"	4	CCW	19
FB166	7/32"	5"	4	CCW	19
FB167	1/4"	5"	4	CCW	19
FB170	3/16"	5 1/2"	4	CW	22

PART NO.	SHAFT	DIAMETER	NO. BLADES	ROTATION	PITCH
FB173	3/16"	5 1/2"	4	CCW	22
FB175	1/4"	5 1/2"	4	CCW	22
FB178	3/16"	6"	4	CW	20
FB180	1/4"	6"	4	CW	20
FB181	3/16"	6"	4	CCW	20
FB182	7/32"	6"	4	CCW	20
FB186	3/16"	6 1/2"	4	CW	20
FB187	7/32"	6 1/2"	4	CW	20
FB188	1/4"	6 1/2"	4	CW	20
FB189	3/16"	6 1/2"	4	CCW	20
FB190	7/32"	6 1/2"	4	CCW	20
FB191	1/4"	6 1/2"	4	CCW	20

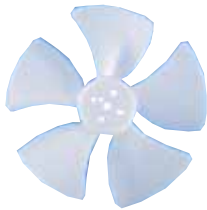

## Plastic Fan Blades Direct Replacement and Hub Type

### Features/Benefits

- Eight Popular Direct Replacements
- Available in Hub or Shaft Mount 1/8", 3/16"
- Clockwise & Counter Clockwise Rotations

### Applications

- Refrigerator & Freezer Evaporators

PART NO.	SHAFT	DIAMETER	BLADES	ROTATION	REPLACEMENT FOR
FB353	HUB	4"	4	CCW	Whpl/Cldspt 513543
FB450	1/8"	4 1/2"	5	CCW	GE WR60X114
FB455	3/16"	5 9/16"	5	CCW	Bohn 5101B
FB718G	HUB	7"	5	CW	GEM FB718 SubZero 3-15-032-0



## Aluminum Condenser Fan Blades

### Features/Benefits

- Aluminum Construction
- 9 Popular Sizes Available
- 6" to 10" Diameter
- Clockwise & Counter Clockwise Rotations
- 5 Blades

### Applications

- Unit Bearing Motors with 1/4" x 20 Threaded Shafts

PART NO.	DIAMETER	NO. OF BLADES	ROTATION	PITCH
FB101	6"	5	CW	30°
FB103	7"	5	CCW	20°
FB104	7"	5	CW	20°
FB105	8"	5	CCW	20°
FB106	8"	5	CW	20°
FB107	8 3/4"	5	CW	20°
FB108	10"	5	CCW	29°
FB109	10"	5	CW	22°

### Tech Tip

#### Fan Blade Rotation

To determine the blade rotation. CW – Clockwise & CCW – Counter Clockwise

1. Lay blade on a flat surface (either side up).
2. The direction of rotation is determined by observing which blade edge touches the flat surface.
3. Left side is touching the flat surface = CW.
4. Right side is touching the flat surface = CCW.

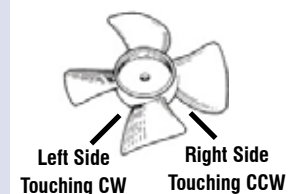

# Pressure Switches



High precision control at economical prices...



## Automatic Reset High, Low & Condenser Fan Cycling Pressure Switches

### Features

- High Pressure SPST open on pressure rise
- Low Pressure SPST open on pressure fall
- Condenser Fan Cycling SPST open on pressure rise
- 1/4" SAE Female flare fitting with valve core depressor
- Snap acting stainless steel hermetically sealed sensor (SHP, SLP & SFC)
- Small size and light weight for direct mounting
- Excellent set point repeatability/stability
- Pressure Range: 0 to 650 PSI
- Burst Pressure: 5000 PSI

- Life @ Rated Load: 100,000 cycles
- Rated Voltage: 50/60 Hz, 24/120 / 240 Volts (6 RLA, 36 LRA)
- Temperatures: Ambient 20°F to 176°F (-30°C to 80°C). Fluid 60°F to 250°F (-50°C to 120°C).

### Applications

- Refrigeration systems
- Air conditioning systems
- Heat pump systems

## Specifications/Competitive Comparison

LOW PRESSURE											
PART NO.	OPEN PSI	CLOSE PSI	TOLERANCE	KLIXON	MARS	A-1	RANCO	ROBERTSHAW	JOHNSON CONTROL	GLOBAL	
SLP0520	5	20	±5 PSI	PS80-K2-F0305-020-005	33329	PS-LP05-20	MPL-7001	3101-001	P100AC-1C	GLP329	
SLP0530	5	30	±5 PSI	N/A	N/A	N/A	N/A	3100-002, MG20-1132	N/A	N/A	
SLP1025	10	25	±5 PSI	PS80-K2-F0307-025-005	33330	PS-LP10-25	MPL-7011	3100-050	P100AP201C	GLP330	
SLP1535	15	35	±5 PSI	PS80-K2-F0312-035-005	33333	N/A	MPL7002	3100-001, MG20-1026	P100AC2	N/A	
SLP2045	20	45	±5 PSI	N/A	N/A	N/A	N/A	3100-003, MG20-1133	N/A	N/A	
SLP2550	25	50	±5 PSI	PS80-K2-F0316-050-005	33362	PS-LP25-50	MPL-7012	MG21-2033	N/A	GLP362	
SLP2565	25	65	±5 PSI	PS80-K2-F0323-065-005	33336	N/A	N/A	3101-002	N/A	N/A	
SLP2580	25	80	±5 PSI	PS80-K2-F0325-080-005	33363	PS-LP25-80	MPL-7003	3101-003, 3100-051	N/A	GLP363	
SLP3560	35	60	±5 PSI	N/A	N/A	N/A	MPL7004	3100-004, MG20-1593	N/A	N/A	
SLP4560	45	60	±5 PSI	N/A	N/A	N/A	MPL7005	N/A	P100AP2C	N/A	
SLP4080	40	80	±5 PSI	PS80-K2-F0326-080-005	33364	PS-LP40-80	MPL-7014	3101-005, 3100-052	N/A	GLP364	
SLP5090	50	90	±5 PSI	PS80-K2-F0328-090-005	33339	N/A	N/A	N/A	N/A	N/A	
SLP75100	75	100	±5 PSI	N/A	N/A	N/A	N/A	N/A	N/A	GLP342410A	
SLP90120	90	120	±5 PSI	N/A	N/A	N/A	N/A	N/A	N/A	N/A	
HIGH PRESSURE											
PART NO.	OPEN PSI	CLOSE PSI	TOLERANCE	KLIXON	MARS	A-1	RANCO	ROBERTSHAW	JOHNSON CONTROL	GLOBAL	
SHP200150	200	150	±15 PSI	PS80-K1-0334-200-150	33353	PS-HP200-150	N/A	N/A	N/A	GHP353	
SHP250150	250	150	±15 PSI	PS80-K1-0336-250-150	33354	PS-HP250-150	N/A	N/A	N/A	GHP354	
SHP250180	250	180	±15 PSI	N/A	N/A	N/A	MPH7101	N/A	N/A	N/A	
SHP275195	275	195	±15 PSI	PS80-K1-0339-275-195	33310	N/A	MPH-7102	3100-112	P100CC9C	N/A	
SHP300200	300	200	±15 PSI	PS80-K1-0341-300-200	33355	PS-HP300-200	MPH-7103	N/A	N/A	GHP355	
SHP325225	325	225	±15 PSI	N/A	N/A	N/A	MPH7104	N/A	N/A	N/A	
SHP325230	325	230	±15 PSI	PS80-K1-0346-325-230	33313	N/A	N/A	N/A	N/A	N/A	
SHP350250	350	250	±15 PSI	PS80-K1-0348-350-250	33356, 33316	PS-HP350250	MPH-7105	3101-201, 3100-150, MG21-1125	N/A	GHP356	
SHP375265	375	265	±15 PSI	PS80-K1-0353-375-265	33319	N/A	MPH-7106	3100-111	N/A	N/A	
SHP400200	400	200	±15 PSI	PS80-K1-0357-400-200	33357	PS-HP400-200	N/A	3100-152	N/A	GHP357	
SHP400280	400	280	±15 PSI	PS80-K1-0358-400-280	33322	N/A	N/A	N/A	N/A	N/A	
SHP400300	400	300	±15 PSI	PS80-K1-0359-400-300	33358	PS-HP400-300	MPH-7107	3101-202, 3100-151, 6 MG21-112	P100CA-1C/ P100CP1C	GHP358	
SHP425300	425	300	±15 PSI	PS80-K1-0360-425-300	33325	N/A	N/A	N/A	N/A	N/A	
SHP425325	425	325	±15 PSI	N/A	N/A	N/A	MPH7108	3100-100/3100-203, MG21-1046	P100CA2C/ P100CP2C	N/A	
SHP450250	450	250	±15 PSI	PS80-K1-0363-450-250	33359	PS-HP450-250	N/A	N/A	N/A	GHP359	
SHP600475	600	475	±15 PSI	N/A	N/A	N/A	N/A	N/A	N/A	GHP361410A	
SHP610420	610	420	±15 PSI	N/A	N/A	N/A	N/A	N/A	N/A	N/A	
MANUAL RESET HP											
PART NO.	OPEN PSI	CLOSE PSI	TOLERANCE	KLIXON	MARS	A-1	RANCO	ROBERTSHAW	JOHNSON CONTROL	GLOBAL	
SMR375	375		±15 PSI	N/A	N/A	N/A	MPH7109	N/A	P100DC3C	N/A	
SMR410	410		±15 PSI	29PSL012-24	33365	PSMF-HP410	MPH7110	3101-301, 3100-103	P100DA-1C	N/A	
SMR440	440		±15 PSI	N/A	N/A	N/A	N/A	3100-104	N/A	N/A	
SMR610	610		±15 PSI	N/A	N/A	N/A	N/A	N/A	N/A	N/A	

# Pressure Switches

## Specifications/Competitive Comparison

FAN CYCLING LP										
PART NO.	OPEN PSI	CLOSE PSI	TOLERANCE	KLIXON	MARS	A-1	RANCO	ROBERTSHAW	JOHNSON CONTROL	GLOBAL
SFC75120	75	120	±15 PSI	N/A	N/A	N/A	MPF7006	N/A	N/A	N/A
SFC110170	110	170	±15 PSI	N/A	N/A	N/A	MPF7007	N/A	N/A	N/A
SFC125265	125	265	±10 PSI	20PS116KA264G126G	33340	N/A	N/A	N/A	N/A	N/A
SFC210275	210	275	±15 PSI	20PS107KA275K210K	33341	N/A	MPF-7009	3101-101,3100-079	N/A	GFC341
SFC150225	150	225	±15 PSI	N/A	N/A	N/A	MPF-7008	N/A	P100AP3C	N/A
SFC170250	170	250	±15 PSI	N/A	N/A	N/A	N/A	N/A	P100AP4C	N/A
SFC200240	200	240	±15 PSI	N/A	N/A	N/A	N/A	3100-080	N/A	N/A
SFC200365	200	365	±15 PSI	N/A	N/A	N/A	N/A	N/A	N/A	N/A
SFC300400	300	400	±15 PSI	N/A	N/A	N/A	MPF7010	N/A	N/A	N/A

Orange = New Items

## Manual Reset High Pressure Switches

- Open on pressure rise
- 1/4" female SAE connection
- Increased reliability
- Maintenance free design
- Bistable disc
- Environmentally sealed sensors
- Safety Feature / Latching mechanism
- Line mount with mechanical fittings
- Pressure Range: 200 – 500 PSI
- Burst Pressure: 3500 PSI
- Proof Pressure: 600 PSI (Short term max over pressure)
- Life @ Rated Load: 30,000 cycles
- Rated Voltage: 50 / 60 Hz , 24 / 120 / 240 Volts (6 RLA, 36 LRA)
- Temperatures: Ambient 20°F to 176°F (-30°C to 80°C).  
Fluid 60°F to 250°F (-50°C to 120°C).

## Specifications/Competitive Comparison

MANUAL RESET										
PART NO.	OPEN PSI	TOLERANCE	KLIXON	MARS	A-1	RANCO	ROBERTSHAW	TECUMSEH	JOHNSON	COPELAND
SMR375	375	±15 PSI				MPH7109			P100DC3C	
SMR410	410	±15 PSI	29PSL012-24	33350	PSMF-HP410	MPH7110	3101-301	N/A 3100-103	P100DA-1C	
SMR440	440	±15 PSI	N/A		N/A	N/A	3100-104	N/A	N/A	
SMR610	610	±15 PSI								NA

# Driers



## SUD Series Copper Driers

SUPCO Copper Driers are high quality, high capacity original equipment components for use on domestic and commercial refrigerators, freezers and air conditioners.

### Features

- 100% XH-9 beaded molecular sieve
- Hermetically sealed
- Copper shells and end tubes
- High capacity
- Easy break off grooved ends

PART NO.	DROPS OF WATER REMOVED				RECOMMENDED TONNAGE	
	R-12		R-22		R-12	R-22
	75°	125°	75°	125°		
SUD103	37.5	34	34	32	1/3	1/2
SUD109	37.5	34	34	32	1/3	1/2
SUD110	37.5	34	34	32	1/3	1/2
SUD111	74	68	68	64	3/4	1
SUD112	99	93	95	90	1	2
SUD113	74	68	68	64	3/4	1
SUD114	74	68	68	64	3/4	1
SUD115	37.5	34	34	32	1/3	1/2
SUD116	74	68	68	64	3/4	1

## SIZE CHART

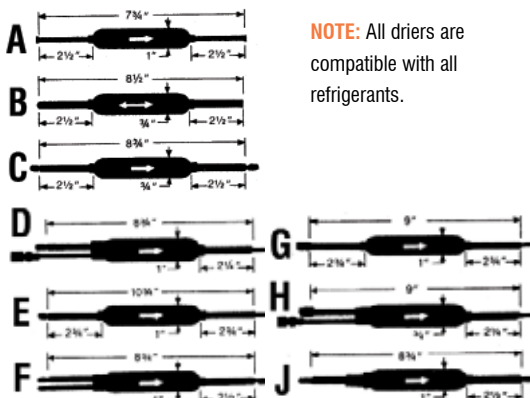

NOTE: All driers are compatible with all refrigerants.

## SUPCO Copper Extended Driers

PART NO.	DESCRIPTION	INLET	OUTLET	DIMENSIONS (SEE CHART)
SUD103	1" Plugged Ends	1/4" O. D.	1/4" O. D.	A
SUD109	3/4" Non-Directional	1/4" O. D.	1/4" O. D.	B
SUD110	3/4" Fused Ends	1/4" O. D.	1/4" O. D.	C
SUD111	1" Charging Drier	1/4" O. D. 1/4" Flare	1/4" O. D. or Cap	D
SUD112	1" Step Down Drier	5/16" O. D.	5/16" O. D. or Cap	E
SUD113	1" Double Inlet	(2)1/4" O. D.	1/4" O. D.	F
SUD114	1" Fused Ends	1/4" I.D. 1/4" O. D.	1/4" O. D. or Cap	G
SUD115	3/4" Charging Drier	1/4" I.D. 1/4" O. D. 1/4" Flare	1/4" O. D. or Cap	H
SUD116	1" Step Down Drier	3/16", 1/4", 5/16" I.D.	5/16" I.D. or Cap	J

# Driers

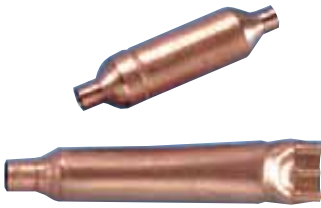

## S200 Series Copper Strainers

SUPCO copper strainers are specifically designed for reopened systems. Each strainer contains an oversized screen area for filtering large quantities of foreign matter from systems that were burnt out.

PART NO.	INLET	OUTLET	O.A. LENGTH	O.D.	FEED
S210	1/4"	.098 CAP	2 3/4"	3/4"	1
S211	1/4"	.125 CAP	2 3/4"	3/4"	1
S212	1/4"	1/4"	2 3/4"	3/4"	1
S213	5/16"	5/16"	2 3/4"	3/4"	1
S214	3/8"	Double Feed Cap .125	4 1/2"	5/8"	2
S215	3/8"	Triple Feed Cap .125	4 1/2"	5/8"	3
S216	3/8"	3/8"	4 1/2"	5/8"	1
S218	3/8"	.125 CAP	4 1/2"	5/8"	1
S219	3/8"	.146 CAP	5"	7/8"	4
S220	3/8"	.112 CAP	4 1/2"	7/8"	6



### Solder Connection Driers

PART NO.	DESCRIPTION	INLET	OUTLET	DROPS OF WATER REMOVED				RECOMMENDED TONNAGE	
				R-12		R-22		R-12	R-22
				75°	125°	75°	125°		
MD5	1" Drier (No Tubes)	1/4"	CAP	37.5	34	34	32	1/3	1/2
MD6	1" Drier (No Tubes)	3/8"	CAP	37.5	34	34	32	1/3	1/2
MD7	1" Drier (No Tubes)	1/4"	1/4"	37.5	34	34	32	1/3	1/2

## CSLD Series / Compact Suction Line Driers



### Features/Benefits

- Dual access valves
- High acid removal
- Solid copper fittings (available in solder only)
- Corrosion resistant epoxy powder paint finish

### Applications

- The CSLD has a compact 14 cubic inch solid block desiccant core, designed when limited space is available.
- Compact suction line filter drier for moisture, acid and contaminant removal.
- For use with CFC, HCFC and HFC refrigerants.

### Specifications

- Maximum working pressure (MWP): 500 PSIG
- Filtration: 40 microns

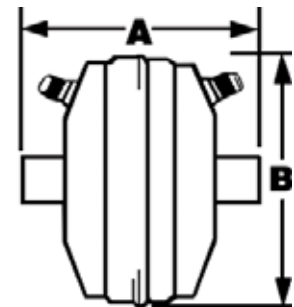

### Nomenclature

Example: CSLD14S5

CSLD	14	S	5
Series	Unit Size Cubic Inches	S=ODF Connection	Connection Size (in 1/8)



PART NO.	CONNECTIONS SIZE & TYPE	DIMENSION IN INCHES A B	FLOW CAPACITY IN TONS REFRIGERANT (1) (FOR KW MULTIPLY TONS BY 3.5 (2))																						
			R-12				R-134a				R-22				R-407C				R-410A						
			EVAPORATOR TEMPERATURE (F)										PRESSURE DROP (PSI)												
			40	20	0	-20	40	20	0	-20	40	20	0	-20	40	20	0	-20	40	20	0	-20			
CSLD14S4	1/2 ODF	4 7/32 4 9/16	1.3	0.9	0.5	0.3	1.3	0.9	0.5	0.3	2	1.3	0.9	0.6	0.3	2.2	1.5	1.1	0.7	0.4	1.4	0.9	0.6	0.4	0.2
CSLD14S5	5/8 ODF	4 1/2 4 9/16	2.2	1.5	0.9	0.6	2.3	1.5	0.9	0.5	3.6	2.4	1.6	1	0.5	4	2.8	1.9	1.2	0.7	2.5	1.6	1.1	0.7	0.3
CSLD14S6	3/4 ODF	4 3/8 4 9/16	3	2.1	1.3	0.8	3.1	2.1	1.3	0.7	4.9	3.2	2.2	1.4	0.7	5.5	3.7	2.7	1.7	0.9	3.3	2.2	1.5	0.9	0.5
CSLD14S7	7/8 ODF	4 9/16 4 9/16	3.2	2.2	1.5	0.8	3.3	2.2	1.4	0.7	5.2	3.4	2.3	1.5	0.8	5.8	3.9	2.8	1.9	1.1	3.6	2.3	1.6	1	0.5
CSLD14S9	1 1/8 ODF	4 27/32 4 9/16	4.4	3.1	1.9	1.1	4.5	3	1.8	1	7	4.6	3.1	2	1	7.8	5.3	3.7	2.5	1.3	4.8	3.2	2.1	1.3	0.7

PART NO.	CONNECTIONS SIZE & TYPE	FLOW CAPACITY IN TONS REFRIGERANT (FOR KW, MULTIPLY TONS BY 3.5)									
		R-502					R-404A/507				
		EVAPORATOR TEMPERATURE (F)									
		40	20	0	-20	-40	40	20	0	-20	-40
CSLD14S4	1/2 ODF	1.3	0.8	0.5	0.3	0.2	1.3	0.8	0.5	0.3	0.2
CSLD14S5	5/8 ODF	2.7	1.7	1.1	0.7	0.3	2.6	1.7	1.1	0.7	0.3
CSLD14S6	3/4 ODF	3.7	2.3	1.5	0.9	0.5	3.6	2.3	1.5	0.9	0.5
CSLD14S7	7/8 ODF	4	2.4	1.6	1	0.5	3.9	2.4	1.6	1	0.5
CSLD14S9	1 1/8 ODF	5.1	3.1	2	1.3	0.7	4.9	3.1	2	1.3	0.7

(1) All ratings in accordance with ARI Standard 730-86

(2) For 2 PSI P, Multiply values by 1.4

Example: 1.0 tons x 3.5 = 3.5 kW



## LLD Series Liquid Line Driers

### Features/Benefits

- Solid copper fittings
- Shock resistant steel construction
- High acid and moisture removal
- Corrosion resistant epoxy powder paint finish

### Specifications

- Desiccant Blend: Activated Alumina with Molecular Sieve
- Filtration: 40 microns
- Maximum working pressure (MWP): 680 psig all LLD Driers

### Applications

- Solid core liquid line filter drier ideal for use with CFC, HCFC and HFC refrigerants including R410A.
- Refrigeration Compressors
  - Air Conditioning Compressors
  - Heat Pump Compressors

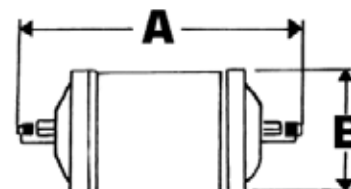

### Nomenclature

Example: LLD083S

<b>LLD</b>	<b>08</b>	<b>3</b>	<b>S</b>
Series	Unit Size Cubic Inches	Connection Size (in 1/8)	S=ODF Connection (Omit for SAE)

### LLD CAPACITY TABLES

PART NO.	Connection SIZE & TYPE	Dimensions in Inches A B		FLOW CAPACITY TONS @ 1 PSI Δ P (1)(4) (FOR KW, MULTIPLY TONS BY 3.5)							WATER CAPACITY / DROPS OF WATER													
				R-12	R-134a	R-22	R-410A	R-407C	R-404A /507	R-502	R-12		R-134a		R-22		R-407C		R-410A		R-404/507		R-502	
											75°F	125°F	75°F	125°F	75°F	125°F	75°F	125°F	75°F	125°F	75°F	125°F	75°F	125°F
LLD032	1/4 SAE	4 5/16	1 5/8	1.6	1.9	2.1	2.1	2	1.4	1.3	64	46	44	37	34	31	31	21	27	17	47	37	43	34
LLD032S	1/4 ODF	3 3/4	1 5/8	1.9	2.3	2.5	2.5	2.4	1.7	1.6														
LLD052	1/4 SAE	4 7/8	2 1/2	1.6	2	2.2	2.2	2.1	1.4	1.4														
LLD052S	1/4 ODF	4 11/32	2 1/2	2.4	2.9	3.1	3.1	3.1	2.1	2	130	81	68	50	58	38	47	26	44	23	73	48	73	49
LLD053	3/8 SAE	5 3/16	2 1/2	3	3.7	4	4	3.9	2.7	2.6														
LLD053S	3/8 ODF	4 17/32	2 1/2	3.7	4.5	4.9	4.9	4.8	3.3	3.2														
LLD082	1/4 SAE	5 13/16	2 1/2	1.6	2	2.2	2.2	2.1	1.4	1.4														
LLD082S	1/4 ODF	5 1/4	2 1/2	2.5	3.1	3.4	3.4	3.3	2.2	2.2														
LLD083	3/8 SAE	6 3/32	2 1/2	3.5	4.3	4.7	4.7	4.6	3.1	3	188	117	101	76	87	57	68	39	63	34	109	73	105	71
LLD083S	3/8 ODF	5 7/16	2 1/2	3.4	4.2	4.6	4.6	4.5	3	3														
LLD084	1/2 SAE	6 11/32	2 1/2	5.5	6.7	7.3	7.3	7.1	4.9	4.7														
LLD084S	1/2 ODF	5 1/2	2 1/2	5.7	7	7.6	7.6	7.4	5.1	4.9														
LLD162	1/4 SAE	6 19/32	2 1/2	1.6	2	2.2	2.2	2.1	1.4	1.4														
LLD163	3/8 SAE	6 7/8	2 1/2	3.6	4.4	4.8	4.8	4.7	3.2	3.1														
LLD163S	3/8 ODF	6 7/32	2 1/2	4	4.9	5.3	5.3	5.2	3.6	3.5														
LLD164	1/2 SAE	7 1/8	2 1/2	6.8	8.3	9	9	8.8	6	5.8	295	204	169	140	151	117	134	86	115	67	180	143	193	145
LLD164S	1/2 ODF	6 9/32	2 1/2	7.1	8.6	9.3	9.3	9.1	6.2	6.1														
LLD165	5/8 SAE	7 1/2	2 1/2	9.7	11.8	12.8	12.8	12.5	8.6	8.3														
LLD165S	5/8 ODF	6 17/32	2 1/2	10.7	13.1	14.2	14.2	13.9	9.5	9.2														
LLD303	3/8 SAE	9 9/16	3	3.9	4.7	5.1		5	3.4	3.3														
LLD303S	3/8 ODF	8 29/32	3																					
LLD304	1/2 SAE	9 13/16	3	7.1	8.6	9.3		9.1	6.2	6.1														
LLD304S	1/2 ODF	8 15/16	3	7.2	8.8	9.5		9.4	6.4	6.2														
LLD305	5/8 SAE	10 3/16	3	11.3	13.8	15		14.7	10	9.7	615	444	359	278	314	218	309	212		385	272	427	335	
LLD306S	3/4 ODF	9 5/8	3	13	15.8	17.1		16.8	11.5	11.1														
LLD307S	7/8 ODF	9 13/16	3	14.3	17.4	18.9		18.5	12.6	12.3														
LLD309S	1 1/8 ODF	9 13/16	3	20.4	24.9	27		26.5	18	17.5														

(1) All ratings in accordance with ARI Standard 710-86.  
 86° F liquid refrigerant temperature  
 5°F saturated vapor temperature  
 3.1 lbs./min./ton for R-134a  
 2.9 lbs./min./ton for R-22 and R-407C  
 4.0 lbs./min./ton for R-404A/507 and R-12  
 4.4 lbs./min./ton for R-502  
 2.7 lbs./min./ton for R-410A

(2) Water Capacities are based on:  
 Equilibrium Point Dryness (EPD) of:  
 50 parts per million for R-134a, R404-A/507,  
 R-410A and R-407C  
 60 parts per million for R-22  
 30 parts per million for R-502  
 15 parts per million for R-12

(3) 20 drops of water = 1 gram = 1 cc  
 (4) For 2 PSI Δ P, Multiply values by 1.4

# Driers

## LLD LIQUID REFRIGERANT HOLDING CAPACITY - OUNCES

UNIT SIZE	R-12		R-134a		R-22		R407C		R-410A		R-404A/507		R-502	
	75°F	125°F	75°F	125°F	75°F	125°F	75°F	125°F	75°F	125°F	75°F	125°F	75°F	125°F
03	2.4	2.2	2.2	2	2.2	2	2.1	1.9	2	1.7	1.9	1.7	2.2	2
05	5.9	6	5.5	5.5	5.4	5.4	5.2	5	4.8	4.5	4.7	4.5	5.5	5.4
08	8	7.4	7.4	6.7	7.3	6.6	7	6.2	6.5	5.5	6.4	5.5	7.5	6.6
16	14.5	12.5	13.4	11.4	13.2	11.2	12.6	10.4	11.7	9.4	11.6	9.3	13.5	11.2
30	21.8	19.9	20.1	18.1	19.8	17.8	18.9	16.6	23.3	19.6	17.4	14.7	20.2	17.7

The LLD filter-drier is UL listed for 680 PSIG maximum working pressure for all sizes.

## LLD LIQUID LINE FILTER DRIERS

FILTER DRIER	REFRIGERATION, LOW TEMP. & COMMERCIAL INSTALLATIONS							AIR CONDITIONING			
								FIELD REPLACEMENT FIELD INSTALLATIONS		& OEM SELF CONTAINED EQUIPMENT	
	R-12/134a	R-22/407C/410A	R-404A/507A	R-12/134a	R-22/407C/410A	R-12/134a	R-22/407C	R-12/134a	R-22/407C		
032,032S,033,033S	1/4	1/4	1/4	1/2	3/4	3/4	1	1			
052,052S	1/3	1/3	1/3	3/4	1	1	1 1/2	1 1/2			
053,053S	1 1/2	2	2	3	3	3	4	4			
082,082S	1/2	1/2	1/2	3/4	1 1/2	1	2	2			
0825S	1	1	1	2	3	3	4	4			
083,083S	1	1	1	2	3	3	4	4			
084,084S	1.5	2	1	3	5	4	7	7			
162,162S	1	1 1/2	3/4	1	2	2	2 1/2	2 1/2			
1625S	2	2 1/2	2	3	4	4	5	5			
163,163S	2	4	2	4	6	5	7 1/2	7 1/2			
164,164S	2	4	2	4	6	5	7 1/2	7 1/2			
165,165S	3	5	2 1/2	5	7 1/2	7 1/2	10	10			
303S	3	3	2	3	4 1/2	4	5	5			
304,304S	3	5	3	5	7 1/2	7 1/2	9	9			
305,305S	5	7 1/2	5	8	10	10	14	14			
306S	7 1/2	7 1/2	5	7 1/2	12 1/2	15	20	20			
307S	7 1/2	7 1/2	5	7 1/2	12 1/2	15	20	20			
309S	7 1/2	10	7 1/2	10	12 1/2	15	20	20			

## SSLD Series / Suction Line Filter Driers



### Features

- Dual access valves
- Solid copper fittings
- Corrosion resistant epoxy powder paint finish

### Applications

- To protect the compressor from dirt and all solid contaminants.

### Specifications

- Filtration: 40 microns
- Maximum working pressure (MWP): 500 psig

### SSLD Dimensions Diagram

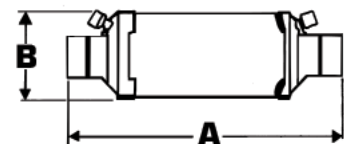

### Nomenclature

Example: **SSLD167S**

<b>SSLD</b>	<b>16</b>	<b>7</b>	<b>S</b>
Series	Unit Size Cubic Inch	Connection Size (in 1/8)	S=ODF Connection (omit for SAE)

## Flow Capacities in Refrigerant Tons at Selected Evaporator Temperatures

PART NO.	CONNECTION SIZE & TYPE	DIMENSION IN INCHES A B		+40°F		+20°F		0°F		-20°F		-40°F		+40°F		+20°F		0°F		-20°F		-40°F	
				R-134a				R-22								R410A							
				PRESSURE DROP IN PSI																			
				2	1.5	1	0.5	3	2	1.5	1	0.5	3	2	1.5	1	0.5	3	2	1.5	1	0.5	
SSLD83	3/8 SAE	6 3/32	2 1/2	0.6	0.4	0.2	0.1	0.9	0.6	0.4	0.3	0.1	1.1	0.8	0.5	0.4	0.1	1.1	0.8	0.5	0.4	0.1	
SSLD83S	3/8 ODF	5 7/16	2 1/2	0.8	0.5	0.3	0.2	1.3	0.8	0.6	0.4	0.2	1.6	1	0.8	0.5	0.3	1.6	1	0.8	0.5	0.3	
SSLD84	1/2 SAE	6 11/32	2 1/2	1.4	0.9	0.6	0.3	2.2	1.4	1	0.6	0.3	2.7	1.8	1.3	0.8	0.4	2.7	1.8	1.3	0.8	0.4	
SSLD84S	1/2 ODF	5 1/2	2 1/2	1.7	1.2	0.7	0.4	2.7	1.8	1.2	0.8	0.4	3.4	2.3	1.6	1.1	0.5	3.4	2.3	1.6	1.1	0.5	
SSLD85	5/8 SAE	6 3/16	2 1/2	2.2	1.5	0.9	0.5	3.4	2.2	1.5	1	0.5	4.2	2.8	2	1.3	0.7	4.2	2.8	2	1.3	0.7	
SSLD85S	5/8 ODF	5 3/4	2 1/2	2.4	1.6	1	0.5	3.8	2.5	1.7	1.1	0.6	4.7	3.2	2.3	1.5	0.8	4.7	3.2	2.3	1.5	0.8	
SSLD164	1/2 SAE	7 1/8	2 1/2	1.5	1	0.6	0.3	2.3	1.5	1	0.7	0.4	2.9	1.9	1.3	0.9	0.5	2.9	1.9	1.3	0.9	0.5	
SSLD165S	5/8 ODF	6 9/16	2 1/2	2.2	1.5	0.9	0.5	3.4	2.2	1.5	1	0.5	4.2	2.8	2	1.3	0.7	4.2	2.8	2	1.3	0.7	
SSLD166	3/4 SAE	6 31/32	2 1/2	2.6	1.8	1.1	0.6	4.1	2.7	1.8	1.2	0.6	5.1	3.4	2.4	1.6	0.8	5.1	3.4	2.4	1.6	0.8	
SSLD166S	3/4 ODF	6 31/32	2 1/2	2.6	1.8	1.1	0.6	4.1	2.7	1.8	1.2	0.6	5.1	3.4	2.4	1.6	0.8	5.1	3.4	2.4	1.6	0.8	
SSLD167S	7/8 ODF	7 1/8	2 1/2	2.7	1.8	1.1	0.6	4.6	2.8	1.9	1.1	0.6	5.6	3.8	2.7	1.7	0.9	5.6	3.8	2.7	1.7	0.9	
SSLD305	5/8 SAE	10 3/16	3	3	2	1.2	0.6	4.7	3.1	2.1	1.3	0.7	5.8	3.9	2.8	1.7	0.9	5.8	3.9	2.8	1.7	0.9	
SSLD305S	5/8 ODF	9 7/32	3	2.8	1.8	1.1	0.6	4.3	2.8	1.9	1.2	0.6	5.3	3.6	2.5	1.6	0.8	5.3	3.6	2.5	1.6	0.8	
SSLD306S	3/4 ODF	9 5/8	3	3.4	2.3	1.4	0.7	5.4	3.5	2.4	1.5	0.8	6.7	4.5	3.2	2	1.1	6.7	4.5	3.2	2	1.1	
SSLD307S	7/8 SAE	9 25/32	3	3.8	2.5	1.6	0.8	5.9	3.9	2.6	1.7	0.9	7.3	5	3.5	2.3	1.2	7.3	5	3.5	2.3	1.2	
SSLD417S													9.4	6.2	4.5	2.8	1.5	9.4	6.2	4.5	2.8	1.5	
SSLD419S	1 1/8 ODF	9 15/16	3 1/2	5.4	3.6	2.2	1.2	8.5	5.5	3.8	2.4	1.3	10.6	7	5.1	3.2	1.8	10.6	7	5.1	3.2	1.8	

## Flow Capacity Chart

PART NO.	Connection SIZE & TYPE	Dimension in Inches		R407C						R-502/R404A/R507					
				Pressure Drop in psi											
		A	B	3	2	1.5	1	0.5	3	2	1.5	1	0.5		
SSLD83	3/8 SAE	6 3/32	2 1/2	1	0.6	0.4	0.3	0.1	0.7	0.5	0.3	0.2	0.1		
SSLD83S	3/8 ODF	5 7/16	2 1/2	1.4	0.9	0.6	0.4	0.2	1	0.7	0.5	0.3	0.1		
SSLD84	1/2 SAE	6 11/32	2 1/2	2.3	1.5	1.1	0.6	0.3	1.8	1.1	0.8	0.5	0.3		
SSLD84S	1/2 ODF	5 1/2	2 1/2	2.9	1.9	1.3	0.8	0.4	2.2	1.4	1	0.6	0.3		
SSLD85	5/8 SAE	6 3/16	2 1/2	3.6	2.3	1.6	1	0.5	2.8	1.8	1.2	0.8	0.4		
SSLD85S	5/8 ODF	5 3/4	2 1/2	4.1	2.7	1.8	1.2	0.6	3.1	2	1.3	0.8	0.4		
SSLD164	1/2 SAE	7 1/8	2 1/2	2.5	1.6	1.1	0.7	0.4	1.9	1.2	0.8	0.5	0.3		
SSLD165S	5/8 ODF	6 9/16	2 1/2	3.6	2.3	1.6	1	0.5	2.8	1.8	1.2	0.8	0.4		
SSLD166	3/4 SAE	6 31/32	2 1/2						3.4	2.2	1.5	0.9	0.5		
SSLD166S	3/4 ODF	6 31/32	2 1/2	4.4	2.9	1.9	1.3	0.6	3.4	2.2	1.5	0.9	0.5		
SSLD167S	7/8 ODF	7 1/8	2 1/2						4.3	2.6	1.7	1	0.6		
SSLD305	5/8 SAE	10 3/16	3	5	3.3	2.2	1.4	0.7	3.8	2.5	1.7	1	0.5		
SSLD305S	5/8 ODF	9 7/32	3	4.6	3	2	1.3	0.6	3.6	2.3	1.5	1	0.5		
SSLD307S	7/8 SAE	9 25/32	3	6.3	4.1	2.7	1.8	0.9	4.9	3.1	2.1	1.3	0.7		
SSLD419S	1 1/8 ODF	9 15/16	3 1/2	9.1	5.9	4	2.5	1.3	6.9	4.5	3	1.9	1		

All ratings in accordance with ARI standard 710-86



## HP Series/Liquid Line Bi-Directional Heat Pump Driers

### Features/Benefits

- 16 cubic inch drier in a 2 1/2" diameter shell
- Internal check valves allow flow and filtration in either direction.
- High moisture and acid removal
- Corrosion resistant epoxy powder paint finish
- Copeland approved for POE oils

### Specifications

- Desiccant blend: 75% molecular sieve and 25% activated alumina (Bead).
- Filtration: 40 microns
- Maximum working pressure (MWP): 680 psig

### Applications

- Bi directional liquid line filter driers for heat pump applications using CFC, HCFC and HFC refrigerants. Including R410A.

### Nomenclature

Example: HP165S

HP	16	5	S
Series	Unit Size Cubic Inches (in 1/8)	Connection Size (Omit for SAE)	S=ODF Connection



## HP CAPACITY TABLES

PART NO.	CONNECTION SIZE & TYPE	DIMENSIONS		FLOW CAPACITY TONS @ 1 PSI Δ P(1)(4)			WATER CAPACITY TONS (2) DROPS OF WATER (3)					
				(FOR kW, MULTIPLY TONS BY 3.5)			R-22		R-407C		R-410A	
		A	B	R-22	R-410A	R-407C	75°F	125°F	75°F	125°F	75°F	125°F
HP083	3/8 SAE	6.28	2.63	4.5	4.5	4.4						
HP083S	3/8 ODF	5.63	2.63	5.1	5.1	5						
HP084	1/2 SAE	6.53	2.63	6.4	6.4	6.3	159	144	106	79	85	75
HP84S	1/2 ODF	5.66	2.63	6.7	6.7	6.6						
HP163	3/8 SAE	6.97	2.63	4.6	4.6	4.5						
HP163S	3/8 ODF	6.31	2.63	5.2	5.2	5.1						
HP164	1/2 SAE	7.22	2.63	7.7	7.7	7.6	323	294	237	179	178	160
HP164S	1/2 ODF	6.34	2.63	8.1	8.1	7.9						
HP165	5/8 SAE	7.59	3.09	8.3	8.3	8.1						
HP165S	5/8 ODF	6.63	2.63	8.7	8.7	8.5						

(1) All ratings in accordance with ARI Standard 710-86.  
86°F liquid refrigerant temperature.  
5°F saturated vapor temperature  
3.1 lbs./min./ton for R-134a  
2.9 lbs./min./ton for R-22 and R-407C  
4.0 lbs. min./ton for R-404A/507 and R-12  
4.4 lbs./min./ton for R-502  
2.7 lbs./min./ton for R-410A

(2) Water Capacities are based on: Equilibrium Point Dryness (EPD) of:  
50 parts per million for R-134a, R404-A/507, R-410A and R-407C  
60 parts per million for R-22  
15 parts per million for R-12  
30 parts per million for R-502

(3) 20 drops of water = 1 gram = 1 cc

(4) For 2 PSI Δ P, Multiply values by 1.4

## HP CAPACITY TABLES

UNIT SIZE	FLOW CAPACITY - TONS @ 1 PSI		LIQUID REFRIGERANT HOLDING CAPACITY - Oz.						WATER HOLDING CAPACITY DROPS					
			R-22R		R-407		R-410A		R-22		R-407C		R-410A	
	R-22/R-410A	R-407C	75°F	125°F	75°F	125°F	75°F	125°F	75°F	125°F	75°F	125°F	75°F	125°F
163S	5.2	5.1												
164	6.6	6.5												
164S	7.4	7.3	10.1	9.1	9.6	8.5	9	7.6	161	141	125	87	91	55
165	8	7.8												
165S	8.3	8.1												

# Driers

## HERMETIC LIQUID LINE HP FILTER DRIERS

UNIT SIZE	REFRIGERATION, LOW TEMP. & COMMERCIAL INSTALLATIONS			AIR CONDITIONING			
				FIELD REPLACEMENT & FIELD INSTALLATIONS		OEM: SELF CONTAINED EQUIPMENT	
	R-12/134A	R-22/407C/410A	R-404A/134A	R-12/134A	R-22/407C/410A	R-12/13A	R-22/407C
083, 083S	1	1	1	2	3	3	4
084, 084S	1.5	2	1	3	5	4	7
162, 162S	1	1.5	3/4	1	2	2	2 1/2
163, 163S	2	4	2	4	6	5	7 1/2
164, 164S	2	4	2	4	6	5	7 1/2
165, 165S	3	5	2 1/2	5	7 1/2	7 1/2	10

## LIQUID REFRIGERANT HOLDING CAPACITY - OUNCES

UNIT SIZE	R-22		R-407C		R-410A	
	75°F	125°F	75°F	125°F	75°F	125°F
05	4.6	4.2	4.4	3.9	4.1	3.5
08	7.7	6.9	7.3	6.4	6.9	5.8
16	14.2	12.7	13.5	11.8	12.6	10.6
30	21.0	18.7	20.0	17.4	--	--

R-410A The HP filter-drier is UL listed for 680 PSIG maximum working pressure for all sizes.



## SSG Series Moisture Indicators

### Features/Benefits

- Fully hermetic design
- 3% relative humidity indication compared to 10% paper indicators.
- Single indicator for all common refrigerants
- Accurate color calibration at low ppm levels and higher temperatures.
- Tri Color Coded
  - Blue = Dry optimal operation conditions, - Purple = Low levels of moisture indicated, - Pink = High levels of moisture detected
- Wide angle viewing high visibility window for ease of monitoring.
- All brass corrosion resistant body
- Solid copper fittings

### Applications

- SUPCO's SSG is designed to provide an accurate method of determining the moisture content of a system's refrigerant.
- Unique 3% high accuracy moisture indicator for CFC, HCFC and HFC refrigerants, including R410A.

### Specifications

- 3% relative humidity sensitivity
- Maximum working pressure (MWP): 680 psig

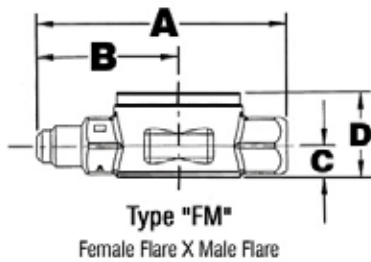

PART NO.	CONNECTION SIZE & TYPE	A	B	C	D	E	F
SSGFM2	1/4 SAE	2.75 ± .03	1.19 ± .03	.34 ± .06	.937 ± .06		
SSGFM3	3/8 SAE	3.00 ± .03	1.31 ± .03	.47 ± .06	1.187 ± .06		
SSGFM4	1/2 SAE	3.22 ± .03	1.41 ± .03	.47 ± .06	1.187 ± .06		
SSGSS2	1/4 ODF	4.62 ± .10		.34 ± .06	.937 ± .06	.254 ± .002	.375
SSGSS3	3/8 ODF	4.62 ± .10		.34 ± .06	.937 ± .06	.379 ± .002	.402
SSGSS4	1/2 ODF	4.87 ± .10		.47 ± .06	1.187 ± .06	.504 ± .003	.500
SSGSS5	5/8 ODF	4.87 ± .10		.47 ± .06	1.187 ± .06	.629 ± .003	.625
SSGSS7	7/8 ODF	6.31 ± .10		.61 ± .06	1.500 ± .06	.879 ± .003	.750

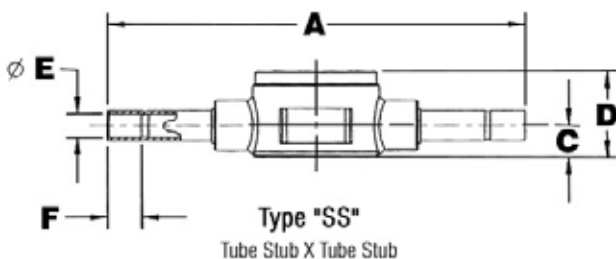

### Nomenclature

Example: SSGSS3

SSG	S	3
Supco Sight Glass	Connection style Solder x Solder	Connection size (in 1/8)

# Cap Tubing



Our Soft Copper Capillary Tubing is precision plug drawn with the internal diameter held to a tolerance of +/- .001. It has been thoroughly dehydrated, sealed and individually packaged.

## BC Series Bullet® Restricto Cap Tubing

Fits **ANY** domestic and commercial refrigerator or room air conditioner from 1/8 H.P. to 5 H.P.

### Features

- Precision Bore, Plus or Minus .001
- The Bullet Restricto Cap is consolidated into a five-pak replacement kit. It's guaranteed to provide you with uniformity on all applications.
- The five "Restricto Cap" sizes cover hundreds of applications (see chart below).
- Specification: ASTM B360

PART NO.	SIZE	LENGTH
BC1	.081 O.D. x .031 I.D.	10 FT. COIL
BC2	.093 O.D. x .040 I.D.	12 FT. COIL
BC3	.093 O.D. x .052 I.D.	12 FT. COIL
BC4	.125 O.D. x .064 I.D.	12 FT. COIL
BC5	.071 O.D. x .028 I.D.	10 FT. COIL
BC1-100	.081 O.D. x .031 I.D.	100 FT. COIL
BC2-100	.093 O.D. x .040 I.D.	100 FT. COIL
BC3-100	.093 O.D. x .052 I.D.	100 FT. COIL
BC4-100	.125 O.D. x .064 I.D.	100 FT. COIL
BC5-100	.071 O.D. x .028 I.D.	100 FT. COIL
5PAK	Five pack replacement kit.	



## CTC3 Cap Tube Computer

Calculate the flow rate of a defective cap tube and duplicate that flow rate with cap tubes that have a different I.D.

### Features/Benefits

- Computes inside diameter, length, refrigerant, horsepower, application and flow rate
- Shows temperature/pressure charts for 12 refrigerants
- Compact, light weight & easy to use!
- Converts Cap Tubing used with refrigerants R12, 134A, R22, and R502 only.

### Added Notes

- Use R12 conversion for R416A
- Use R134 conversion for R401A, R401B, R406A, R500, R409A
- Use R502 conversion for R402B, R403B, R404A, R407C, R408A

## Reference chart for Bullet® "Restricto" Capillary Tubing for All Refrigerants in Low, Medium and High Applications

**NOTE:** This chart is average measurements for average conditions, and may have to be "fine tuned" for exact replacement. These charts are for Fan Cooled units only. Add 10% to the length of the cap tubing for Static Cooled Units.

**NOTE:** Application Temperatures are Saturated Suction Temperatures (SST).

### SINGLE FEED

REF	hp	-10 LOW	+20 MED	+45 HIGH
R12/R416A	1/8 hp	110" # 5	84" # 5	48" # 5
	1/6 hp	71" # 5	96" # 1	72" # 1
	1/5 hp	54" # 1	36" # 1	24" # 1
	1/4 hp	43" # 1	90" # 2	60" # 2
	1/3 hp	93" # 2	72" # 2	36" # 2
	1/2 hp	96" # 3	48" # 3	90" # 4
	3/4 hp	60" # 3	92" # 4	72" # 4
	1 hp	36" # 3	84" # 4	54" # 4
	1-1/2 hp	84" # 4	60" # 4	43" # 4
	2 hp	55" # 4	40" # 4	26" # 4

REF	hp	-10 LOW	+20 MED	+45 HIGH
R134A / R401A	1/8 hp	121" # 5	92" # 5	53" # 5
R401B/R406A	1/6 hp	78" # 5	106" # 1	79" # 1
R409A/R500	1/5 hp	59" # 1	39" # 1	26" # 1
	1/4 hp	47" # 1	99" # 2	66" # 2
	1/3 hp	102" # 2	79" # 2	39" # 2
	1/2 hp	105" # 3	52" # 3	99" # 4
	3/4 hp	66" # 3	101" # 4	79" # 4
	1 hp	39" # 3	92" # 4	59" # 4
	1-1/2 hp	92" # 4	66" # 4	47" # 4
	2 hp	61" # 4	44" # 4	29" # 4

**NOTE:** For Multiple Feeds with smaller HP's than those shown in the charts.

- Divide HP by number of feeds, go to Single Feed Chart, select a cap tube for the calculated HP and use that selection for each feed.
- Ex: 1 HP, LOW, R12 5 FEED USE: 1/5 HP, LOW, R12, SINGLE FEED CHART
- RESULT: 5 Feeds, 54" BC1

# Cap Tubing

## SINGLE FEED

REF	hp	-10 LOW	+20 MED	+45 HIGH	
<b>R22</b>	1/8 hp	132" #5	101" #5	58" #5	
	1/6 hp	86" #5	116" #1	86" #1	
	1/5 hp	64" #1	42" #1	28" #1	
	1/4 hp	51" #1	109" #2	72" #2	
	1/3 hp	112" #2	87" #2	43" #2	
	1/2 hp	115" #3	57" #3	109" #4	
	3/4 hp	72" #3	111" #4	87" #4	
	1 hp	42" #3	101" #4	65" #4	
	1-1/2 hp	101" #4	72" #4	51" #4	
	2 hp	67" #4	48" #4	32" #4	
	<b>R402A/R407A R407B/R507</b>	1/8 hp	N/A	122" #5	69" #5
		1/6 hp	104" #5	138" #1	105" #1
1/5 hp		77" #1	50" #1	34" #1	
1/4 hp		62" #1	34" #1	86" #2	
1/3 hp		33" #1	106" #2	52" #2	
1/2 hp		31" #2	69" #3	35" #3	
3/4 hp		87" #3	37" #3	106" #4	
1 hp		52" #3	30" #3	79" #4	
1-1/2 hp		32" #3	86" #4	62" #4	
2 hp		82" #4	58" #4	37" #4	

REF	hp	-10 LOW	+20 MED	+45 HIGH	
<b>R402B/R403B R404A/R407C R408A/R502</b>	1/8 hp	144" #5	111" #5	63" #5	
	1/6 hp	95" #5	78" #5	95" #1	
	1/5 hp	70" #1	46" #1	31" #1	
	1/4 hp	56" #1	31" #1	79" #2	
	1/3 hp	30" #1	96" #2	47" #2	
	1/2 hp	29" #2	63" #3	32" #3	
	3/4 hp	79" #3	32" #3	96" #4	
	1 hp	46" #3	111" #4	72" #4	
	1-1/2 hp	111" #4	79" #4	56" #4	
	2 hp	74" #4	52" #4	34" #4	
	<b>R410A</b>	1/8 hp	N/A	144" #5	81" #5
		1/6 hp	123" #5	100" #5	78" #5
1/5 hp		90" #1	60" #1	41" #1	
1/4 hp		73" #1	40" #1	101" #2	
1/3 hp		38" #1	30" #1	62" #2	
1/2 hp		37" #2	84" #3	42" #3	
3/4 hp		104" #3	44" #3	34" #3	
1 hp		62" #3	36" #3	94" #4	
1-1/2 hp		38" #3	103" #4	74" #4	
2 hp		96" #4	69" #4	45" #4	

## DOUBLE FEED

(All double feed caps tubes require 2 lengths of each size listed below.)

REF	hp	-10 LOW	+20 MED	+45 HIGH
<b>R12/R416A</b>	1/2 hp	43" #1	90" #2	60" #2
	3/4 hp	30" #1	63" #2	42" #2
	1 hp	96" #3	48" #3	90" #4
	1 1/2 hp	60" #3	92" #4	72" #4
	2 hp	36" #3	84" #4	54" #4
	2 1/2 hp	108" #4	72" #4	49" #4
	3 hp	84" #4	60" #4	43" #4
	3 1/2 hp	70" #4	54" #4	35" #4
	4 hp	55" #4	40" #4	26" #4
	<b>R134A/R401A R401B/R406B R409A/R500</b>	1/2 hp	47" #1	99" #2
3/4 hp		33" #1	69" #2	46" #2
1 hp		105" #3	52" #3	99" #4
1 1/2 hp		66" #3	101" #4	79" #4
2 hp		40" #3	92" #4	59" #4
2 1/2 hp		119" #4	79" #4	53" #4
3 hp		92" #4	66" #4	47" #4
3 1/2 hp		77" #4	59" #4	38" #4
4 hp		60" #4	44" #4	29" #4
<b>R22</b>		1/2 hp	52" #1	108" #2
	3/4 hp	36" #1	77" #2	50" #2
	1 hp	115" #3	58" #3	108" #4
	1 1/2 hp	72" #3	110" #4	86" #4
	2 hp	43" #3	101" #4	65" #4
	2 1/2 hp	39" #3	87" #4	58" #4
	3 hp	101" #4	72" #4	52" #4
#4	3 1/2 hp	84" #4	64" #4	#4
41"	#4	4 hp	66" #4	48" #4

REF	hp	-10 LOW	+20 MED	+45 HIGH
<b>R402B/R403B R404A/R407C R408A/R502</b>	1/2 hp	56" #1	119" #2	78" #2
	3/4 hp	39" #1	85" #2	55" #2
	1 hp	28" #2	63" #3	119" #4
	1 1/2 hp	79" #3	32" #3	94" #4
	2 hp	47" #3	110" #4	71" #4
	2 1/2 hp	43" #3	96" #4	64" #4
	3 hp	111" #4	79" #4	57" #4
	3 1/2 hp	92" #4	70" #4	46" #4
	4 hp	73" #4	53" #4	34" #4
	<b>R402A/R407A R407B/R507</b>	1/2 hp	62" #1	32" #1
3/4 hp		43" #1	92" #2	60" #2
1 hp		31" #2	70" #3	36" #3
1 1/2 hp		87" #3	35" #3	103" #4
2 hp		52" #3	28" #3	78" #4
2 1/2 hp		47" #3	106" #4	70" #4
3 hp		32" #3	86" #4	62" #4
3 1/2 hp		101" #4	77" #4	50" #4
4 hp		80" #4	58" #4	37" #4
<b>R410A</b>		1/2 hp	72" #1	37" #1
	3/4 hp	50" #1	116" #2	70" #2
	1 hp	37" #2	83" #3	42" #3
	1 1/2 hp	102" #3	44" #3	34" #3
	2 hp	62" #3	37" #3	93" #4
	2 1/2 hp	55" #3	32" #3	81" #4
	3 hp	38" #3	101" #4	74" #4
	3 1/2 hp	118" #4	90" #4	55" #4
	4 hp	92" #4	70" #4	41" #4

## TRIPLE FEED

(All triple feed cap tubes require 3 lengths of each size listed below.)

REF	hp	-10 LOW	+20 MED	+45 HIGH
<b>R12/R416A</b>	1 hp	93" #2	72" #2	36" #2
	1 1/2 hp	96" #3	48" #3	90" #4
	2 hp	77" #3	38" #3	72" #4
	3 hp	36" #3	84" #4	54" #4
	4 hp	108" #4	63" #4	41" #4
	5 hp	86" #4	50" #4	32" #4
<b>R134A/R401A R401B/R406A R409A/R500</b>	1 hp	102" #2	79" #2	39" #2
	1 1/2 hp	105" #3	52" #3	99" #4
	2 hp	84" #3	42" #3	79" #4
	3 hp	40" #3	92" #4	59" #4
	4 hp	30" #3	69" #4	45" #4
<b>R22</b>	1 hp	112" #2	86" #2	43" #2
	1 1/2 hp	37" #2	58" #3	108" #4
	2 hp	92" #3	46" #3	86" #4
	3 hp	43" #3	100" #4	65" #4
	4 hp	32" #3	75" #4	49" #4
	5 hp	102" #4	60" #4	39" #4

REF	hp	-10 LOW	+20 MED	+45 HIGH
<b>R402B/R403B R404A/R407C R408A/R502</b>	1 hp	30" #1	94" #2	47" #2
	1 1/2 hp	41" #2	63" #3	32" #3
	2 hp	101" #3	50" #3	95" #4
	3 hp	47" #3	110" #4	71" #4
	4 hp	35" #3	83" #4	53" #4
	5 hp	32" #3	66" #4	43" #4
<b>R402A/R407A R407B/R507</b>	1 hp	33" #1	104" #2	52" #2
	1 1/2 hp	45" #2	70" #3	35" #3
	2 hp	111" #3	55" #3	104" #4
	3 hp	52" #3	31" #3	78" #4
	4 hp	38" #3	91" #4	58" #4
<b>R410A</b>	1 hp	39" #1	30" #1	62" #2
	1 1/2 hp	54" #2	84" #3	42" #3
	2 hp	27" #2	66" #3	32" #3
	3 hp	62" #3	37" #3	94" #4
	4 hp	46" #3	109" #4	68" #4
	5 hp	42" #3	86" #4	56" #4

# Cap Tubing

## FOUR FEED (All four feed cap tubes require 4 lengths of each size listed below.)

REF	hp	-10 LOW	+20 MED	+45 HIGH
R12/R416A	2 hp	96" #3	48" #3	90" #4
	3 hp	60" #3	92" #4	72" #4
	4 hp	36" #3	84" #4	54" #4
	5 hp	105" #4	67" #4	43" #4
R134A/R401A R401B/R406A R409A/R500	2 hp	105" #3	52" #3	99" #4
	3 hp	66" #3	101" #4	79" #4
	4 hp	40" #3	92" #4	59" #4
	5 hp	32" #3	74" #4	47" #4
R22	2 hp	115" #3	58" #3	108" #4
	3 hp	72" #3	110" #4	86" #4
	4 hp	44" #3	101" #4	65" #4
	5 hp	35" #3	81" #4	52" #4

REF	hp	-10 LOW	+20 MED	+45 HIGH
R402B/R403B R404A/R407C R408A/R502	2 hp	29" #2	63" #3	32" #3
	3 hp	79" #3	32" #3	94" #4
	4 hp	47" #3	111" #4	71" #4
	5 hp	38" #3	89" #4	57" #4
	5 hp	38" #3	89" #4	57" #4
R402A/R407A R407B/R507	2 hp	31" #2	70" #3	35" #3
	3 hp	87" #3	35" #3	103" #4
	4 hp	52" #3	31" #3	78" #4
	5 hp	42" #3	97" #4	63" #4
R410A	2 hp	34" #2	81" #3	41" #3
	3 hp	101" #3	48" #3	32" #3
	4 hp	62" #3	36" #3	92" #4
	5 hp	49" #3	30" #3	74" #4

## FIVE FEED (All five feed cap tubes require 5 lengths of each size listed below.)

REF	hp	-10 LOW	+20 MED	+45 HIGH
R12/R416A	2 hp	115" #3	58" #3	108" #4
	3 hp	81" #3	41" #3	77" #4
	4 hp	57" #3	87" #4	68" #4
	5 hp	36" #3	82" #4	54" #4
R134A/R401A R401B/R406B R409A/R500	2 hp	28" #2	62" #3	32" #3
	3 hp	89" #3	45" #3	84" #4
	4 hp	62" #3	95" #4	74" #4
	5 hp	40" #3	92" #4	59" #4
R22	2 hp	32" #2	70" #3	35" #3
	3 hp	97" #3	49" #3	92" #4
	4 hp	68" #3	103" #4	81" #4
	5 hp	48" #3	98" #4	65" #4

REF	hp	-10 LOW	+20 MED	+45 HIGH
R402B/R403B R404A/R407C R408A/R502	2 hp	35" #2	77" #3	38" #3
	3 hp	108" #3	54" #3	101" #4
	4 hp	74" #3	114" #4	89" #4
	5 hp	53" #3	108" #4	71" #4
	5 hp	53" #3	108" #4	71" #4
R402A/R407A R407B/R507	2 hp	38" #2	84" #3	42" #3
	3 hp	28" #2	59" #3	30" #3
	4 hp	81" #3	35" #3	99" #4
	5 hp	58" #3	31" #3	78" #4
R410A	2 hp	45" #2	98" #3	49" #3
	3 hp	31" #2	69" #3	35" #3
	4 hp	95" #3	40" #3	30" #3
	5 hp	67" #3	36" #3	91" #4

## SIX FEED (All six feed cap tubes require 6 lengths of each size listed below.)

REF	hp	-10 LOW	+20 MED	+45 HIGH
R12/R116A	2 hp	93" #2	72" #2	36" #2
	3 hp	96" #3	48" #3	90" #4
	4 hp	82" #3	41" #3	77" #4
	5 hp	56" #3	86" #4	68" #4
R134A/R401A R401B/R406A R409A/R500	2 hp	102" #2	79" #2	39" #2
	3 hp	105" #3	52" #3	99" #4
	4 hp	90" #3	45" #3	85" #4
	5 hp	62" #3	95" #4	75" #4
R22	2 hp	112" #2	86" #2	43" #2
	3 hp	115" #3	58" #3	108" #4
	4 hp	98" #3	49" #3	92" #4
	5 hp	68" #3	103" #4	81" #4

REF	hp	-10 LOW	+20 MED	+45 HIGH
R402B/R403B R404A/R407C R408A/R502	2 hp	30" #1	94" #2	47" #2
	3 hp	29" #2	63" #3	32" #3
	4 hp	118" #3	53" #3	27" #3
	5 hp	74" #3	30" #3	89" #4
	5 hp	74" #3	30" #3	89" #4
R402A/R407A R407B/R507	2 hp	33" #1	103" #2	52" #2
	3 hp	31" #2	70" #3	35" #3
	4 hp	26" #2	58" #3	30" #3
	5 hp	82" #3	33" #3	98" #4
R410A	2 hp	40" #1	31" #1	62" #2
	3 hp	37" #2	85" #3	42" #3
	4 hp	33" #2	70" #3	36" #3
	5 hp	98" #3	40" #3	32" #3

**NOTE:** For Multiple Feeds with smaller hp's than those shown in the charts.

- Divide hp by number of feeds, go to Single Feed Chart, select a cap tube for the calculated hp and use that selection for each feed.
- Ex: 1 hp, LOW, R12 5 FEED USE: 1/5 hp, LOW, R12, SINGLE FEED CHART
- RESULT: 5 Feeds, 54" BC1

# Belts



## Multi-Plus Dual Brand V-Belts

Clearly identifying RMA classic part number and dimensionally equivalent FHP number, the Multi-plus belt is designed to reduce total V-Belt investment.

- Consolidate belts sizes into a single belt line
- Able to handle classic and FHP drive applications

### Applications

- HVAC
- Refrigeration
- Industrial



“A & B” Sec-



“BX” Section

### “A” Section Classical V Belts

- 1/2 inch top width
- 11/32 inch thick
- Dual Brand A & 4L

### “B” Section Classical V Belts

- 21/32 inch top width
- 13/32 inch thick
- Dual Brand B & 5L

### “BX” Section Cogged Multiple V Belts

- 21/32 inch top width
- 13/32 inch thick

Belt Section (Pitch)	b (Angle)	bb (Width)	hb (Height)
A	40°	.50 in	.31 in
B, BX	40°	.66 in	.41 in

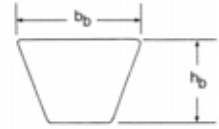

PART NO.	CROSS to L's	APPROX. OUTSIDE LENGTH	PART NO.	CROSS to L's	APPROX. OUTSIDE LENGTH	PART NO.	CROSS to L's	APPROX. OUTSIDE LENGTH	PART NO.	CROSS to L's	APPROX. OUTSIDE LENGTH	PART NO.	CROSS to L's	APPROX. OUTSIDE LENGTH
A100	4L1020	102	A65	4L670	67	B44	5L470	47	B102		105	BX66		69
A105		107	A66	4L680	68	B45	5L480	48	B104		107	BX67		70
A110		112	A67	4L690	69	B46	5L490	49	B105		108	BX70		73
A112		114	A68	4L700	70	B47	5L500	50	B106		109	BX71		74
A116		118	A69	4L710	71	B48	5L510	51	B107		110	BX75		78
A120		122	A70	4L720	72	B49	5L520	52	B110		113	BX77		80
A124		126	A71	4L730	73	B50	5L530	53	B111		114	BX78		81
A128		130	A72	4L740	74	B51	5L540	54	B112		115	BX80		83
A136		138	A73	4L750	75	B52	5L550	55	B114		117	BX81		84
A144		146	A74	4L760	76	B53	5L560	56	B115		118	BX82		85
A158		160	A75	4L770	77	B54	5L570	57	B116		119	BX83		86
A19	4L210	21	A76	4L780	78	B55	5L580	58	B118		121	BX90		93
A20	4L220	22	A77	4L790	79	B56	5L590	59	B120		123	BX93		96
A21	4L230	23	A78	4L800	80	B57	5L600	60	B124		127	BX95		98
A22	4L240	24	A79	4L810	81	B58	5L610	61	B126		129	BX96		99
A23	4L250	25	A80	4L820	82	B59	5L620	62	B128		131	BX97		100
A24	4L260	26	A81	4L830	83	B60	5L630	63	B130		133	BX99		102
A25	4L270	27	A82	4L840	84	B61	5L640	64	B133		136	BX100		103
A26	4L280	28	A83	4L850	85	B62	5L650	65	B134		137	BX103		106
A27	4L290	29	A84	4L860	86	B63	5L660	66	B135		138	BX105		108
A28	4L300	30	A85	4L870	87	B64	5L670	67	B136		139	BX112		115
A29	4L310	31	A86	4L880	88	B65	5L680	68	B140		143	BX116		119
A30	4L320	32	A87	4L890	89	B66	5L690	69	B144		147	BX120		123
A31	4L330	33	A88	4L900	90	B67	5L700	70	B152		155	BX124		127
A32	4L340	34	A89	4L910	91	B68	5L710	71	B158		161	BX128		131
A33	4L350	35	A90	4L920	92	B69	5L720	72	B162		165	BX133		135
A34	4L360	36	A91	4L930	93	B70	5L730	73	B195		198	BX136		139
A35	4L370	37	A92	4L940	94	B71	5L740	74	B210		213	BX144		147
A36	4L380	38	A93	4L950	95	B72	5L750	75	B225		227	BX150		153
A37	4L390	39	A94	4L960	96	B73	5L760	76	B240		242	BX158		161
A38	4L400	40	A95	4L970	97	B74	5L770	77	B255		257	BX162		163
A39	4L410	41	A96	4L980	98	B75	5L780	78	B270		272	BX173		176
A40	4L420	42	A97	4L990	99	B76	5L790	79	B285		287	BX180		183
A41	4L430	43	A98	4L1000	100	B77	5L800	80	B300		302	BX195		198
A42	4L440	44	A99	4L1010	101	B78	5L810	81	B315		317	BX210		213
A43	4L450	45	B23	5L260	26	B79	5L820	82	B330		332	BX225		226.5
A44	4L460	46	B24	5L270	27	B80	5L830	83	B360		362	BX240		241.5
A45	4L470	47	B25	5L280	28	B81	5L840	84	BX35		38	BX255		256.5
A46	4L480	48	B26	5L290	29	B82	5L850	85	BX36		39	BX270		271.5
A47	4L490	49	B27	5L300	30	B83	5L860	86	BX38		41	BX300		301.5
A48	4L500	50	B28	5L310	31	B85	5L880	88	BX42		45			
A49	4L510	51	B29	5L320	32	B86	5L890	89	BX43		46			
A50	4L520	52	B30	5L330	33	B87	5L900	90	BX46		49			
A51	4L530	53	B31	5L340	34	B88	5L910	91	BX48		51			
A52	4L540	54	B32	5L350	35	B89	5L920	92	BX50		53			
A53	4L550	55	B33	5L360	36	B90	5L930	93	BX51		54			
A54	4L560	56	B34	5L370	37	B91	5L940	94	BX53		56			
A55	4L570	57	B35	5L380	38	B92	5L950	95	BX55		58			
A56	4L580	58	B36	5L390	39	B93	5L960	96	BX56		59			
A57	4L590	59	B37	5L400	40	B94	5L970	97	BX58		61			
A58	4L600	60	B38	5L410	41	B95	5L980	98	BX59		62			
A59	4L610	61	B39	5L420	42	B96	5L990	99	BX60		63			
A60	4L620	62	B40	5L430	43	B97	5L1000	100	BX61		64			
A61	4L630	63	B41	5L440	44	B98	5L1010	101	BX62		65			
A62	4L640	64	B42	5L450	45	B99	5L1020	102	BX63		66			
A63	4L650	65	B43	5L460	46	B101		104	BX65		68			

We have the full product line of HVAC Belts • Please call if you need other belts.

See page 105 for Belt Adjustment Tools (BJ10)

## DH Series Duct Heater Coil Kits

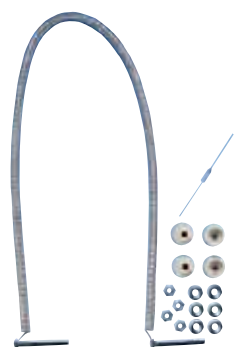

DH500  
(DH500 Series 3/8" O.D.)

### Features/Benefits

- Nichrome heavy gauge construction.
- Welded terminal bolts for low resistance and longer life.
- Complete kits contain close wound coil to fit many applications, two male and two female bushings, terminal screws, nuts and washers to make a proper repair. The DH500 & DH500FC kits include the SUPCO STC in line series thermal cutoffs.

### Applications

Replacement coil kits for many electric heat applications.

- Duct Heaters
- Electric Furnaces
- Air Curtains
- Strip Heaters

PART NO.	MARS PART NO.	CLOSE WOUND LENGTH	WATTAGE AT VOLTS	WATTAGE AT VOLTS
DH500*	34601	28"	5000@240	3750@208
DH500-3		23"	5000@480	
DH500FC*		12"	5000@240	3750@208
DH501	34608	22"	3500@240	2600W@208
DH502-4		18"	2000@277	
DH506	34630	26 1/2"	4000@240	
DH507		18 1/2"	3000@240	2250@208
DH520	34652	31 1/2"	6600@240	5000@208
DH534	34656	26"	6000@240	4500@208
DH560		28"	5600@240	4200@208

\*Includes 306°F Thermal Cutoff SUPCO p/n STC4300



DH500FC  
(5/8" O.D.)

### Tech Tip

The coil should be evenly stretched a minimum of 1 1/2 to 5 times the close wound length.

### Tech Tip

When stretching coils measure length needed and stretch new coil slightly shorter. After installation, cycle with the heater on and allow full operation for 5 minutes. Any manufacturing flaws in the coil will show up quickly.



## STC Series Thermal Cutoffs

## THERMODISC®

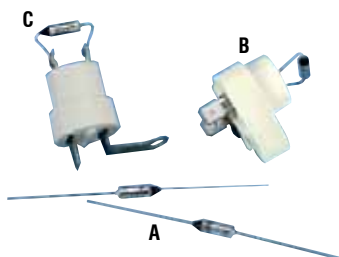

### Features/Benefits

- STC thermal cutoffs are available in a range of temperature and electrical ratings to meet a variety of different applications.
- Provides reliable back up protection for temperature controlling thermostats and other over temperature conditions.
- One time operation.
- Three configurations available to accommodate in line or face plate mounting.
- Rated for continuous operating currents of up to 10 amps @ 250VAC (15 amps @ 120VAC).
- Used with the SUPCO DH series duct heaters.

### Applications

Manufactured as a thermal safeguard, the SUPCO STC opens the circuit if the designed temperature limit is reached.

- Duct heaters
- Electric furnaces
- Heat Pump systems
- Portable electric heaters
- Industrial equipment
- Office machines

PART NO.	T-O-D	DIVERSITEC	A-1	OPEN TEMP °F	OPEN TEMP °C	TYPE	REF.
STC4257	G4A01128C	HFL4257	TC4257	262°F	128°C	In Line	A
STC4283	G4A01144C		TC4283	291°F	144°C	In Line	A
STC4300	G4A01152C	HFL4300	TC4300	306°F	152°C	In Line	A
STC4333	G4A01167C	HFL4333	TC4333	333°F	167°C	In Line	A
STC4358	G4A01184C			363°F	184°C	In Line	A
STC4438	G4A01228C		TC4438	442°F	228°C	In Line	A
STC4468	G4A01240C		TC4468	464°F	240°C	In Line	A
STC5257	G4AM0600128C	HFL5257	TC5257	262°F	128°C	Face Plate Straight	B
STC5300	G4AM0600152C	HFL5300	TC5300	306°F	152°C	Face Plate Straight	B
STC5333	G4AM0600167C	HFL5333	TC5333	333°F	167°C	Face Plate Straight	B
STC5337				337°F	169°C		
STC5377	G4AM0600192C		TC5377	378°F	192°C	Face Plate Straight	B
STC6257	G4AM0600128C			262°F	128°C	Face Plate Right Angle	C
STC6300	G4AM0600152C			306°F	152°C	Face Plate Right Angle	C
STC6333	G4AM0600167C			333°F	167°C	Face Place Right Angle	C



# Heaters

## CH Series Compressor Heaters



### Features/Benefits

- Prevents refrigerant migration which causes compressor damage.
- Entire heating band is corrosion resistant
- Installs quickly and easily
- Low power consumption
- High temperature silicone rubber element
- 30" long insulated leads

### Applications

- Air Conditioning
- Heat Pumps
- Refrigeration Compressors



PART NO.	VOLTS	WATTS	GIRTH DIM. MIN.	GIRTH DIM. MAX.	COPELAND PART NO.	MARS PART NO.	FITS COMPRESSOR
CH101	240	54	27 7/16"	34 1/4"		32605	Aspera: H, Bendix / Westinghouse: E,
CH101-3	480	54	27 7/16"	34 1/4"	018-0037-03	32608	
CH102	240	60	25 3/4"	32 9/16"		32609	Tecumseh: AJ, Trane: D4340/7669
CH103	240	45	24 3/4"	31 9/16"	018-0038-02	32613	Bristol: H10B, H20B, H21G, H22B, H2NG-144
CH104	240	75	41 1/2"	48 5/16"		32617	Carrier: 6A88, Fedder Chrysler 3009
CH1042	120	75	41 1/2"	48 5/16"		32619	Bristol: H106, H206, H21G, H22G
CH105	240	50	32 1/2"	39 5/16"		32621	Copeland: ZR, Trane: DE4340, 7570
CH1053	480	50	32 1/2"	39 5/16"		32624	
CH1202	120	90	30 3/16"	37"			Copeland: BR
CH135	240	45	23 7/16"	27 1/2"		32629	
CH197	240	25	13 3/4"	20 9/16"		32631	Fedders Chrysler: 2870908, Sanyo: CR151F, CR20F, CR33F

# Transformers

## Universal Fan Centers

Two economically priced products to choose from that cover all applications.



## FC4011 & Universal FC4031

### Features/Benefits

- DPDT plug-in style relay (90340)
- 40 VA transformer
- Mounts directly to 4" x 4" electrical box
- Color coded wiring for easy installation
- Universal FC4031 includes multi tap primary voltages for all applications, reduces inventory

### Applications

- Provides low voltage control of line voltage fan motors and auxiliary circuits in HVAC systems



### SPECIFICATIONS

PART NO.	VA	PRIMARY VAC	SECONDARY VAC	hp	CONTACTS	REPLACES JARD	REPLACES MARS	REPLACES STEVECO
FC4011	40	120	24	3/4	DPDT	4011FC	24013	90-113
FC4031	40	120/208/240	24	3/4	DPDT	4031FC	24010	90-130

## T45 Universal Transformer

A versatile transformer that can be used for many different applications. Accepts input voltages of 120, 208, and 240 VAC and provides a choice of secondary voltages of 2.5, 8, 12, 16 and 24 VAC.

- 50/60 Hz Class 2
- Enclosed Frame - Plate, Foot or Knock-Out Mount



PART NO.	PRIMARY VAC	SECONDARY VAC	VA	H	W	D	MW
T45	120/208/240	2.5, 8, 12, 16 & 24	48	2 1/16"	3 1/4"	2 3/4"	2 13/16"

**NOTE:** Transformer is furnished with a 4" x 4" mounting plate, wire nuts, 1/2" conduit and 8" leads.



# Transformers

## Control Transformers

A complete line of Control Transformers designed for HVAC/R applications.

- Foot or Multi-mount
- Output from 20 – 100 VA
- A multitude of Primary and Secondary combinations
- Circuit breakers and fuses where noted

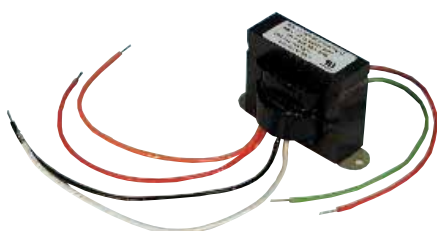

SXT105

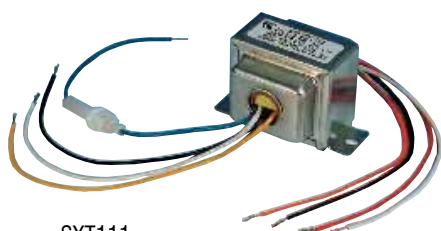

SXT111

### Foot Mount Transformers

PART NO.	PRIMARY V	SECONDARY V	OUTPUT VA	BREAKER/FUSE	MOUNT TYPE
SXT100R	120/208/240/480	24	100	Breaker	Foot
SXT101	120/208/240	2.5/12/24	40	Fuse	Foot
SXT103	277	24	40	No	Foot
SXT104	208/240	24	40	No	Foot
SXT105	120/208/240	24	40	No	Foot
SXT114	120/208/240	24	20	No	Foot
* SXT115	120/208/240	24	40	No	Foot
SXT116	120	24	40	No	Foot
SXT160	208/240	24	60	Fuse	Foot
SXT79R	120/208/240/480	24	75	Breaker	Foot

\* Includes Metal Shroud.

### Multi-Mount Transformers

PART NO.	PRIMARY V	SECONDARY V	OUTPUT VA	BREAKER/FUSE	MOUNT TYPE
SXT106	120/208/240	24	40	No	Multi
SXT111	120/208/240	2.5/12/24	40	Fuse	Multi
SXT112	120	24	40	No	Multi
SXT113	208/240	24	40	No	Multi
SXT148	120/208/240	2.5/12/24	48	No	Multi
SXT150	120/208/240	24	50	Fuse	Multi

## Cross Reference

### Foot Mount

PART NO.	JARD	MARS	UEI	WHITE-RODGERS	HONEYWELL
SXT101	4032F	50355	UET101	N/A	N/A
SXT104	4021F	50353	N/A	90-T40F2	AT40A1139, AT40B1032
SXT105	4031F	50354	UET105	90-T40F3	AT40A1121, AT40A1139, AT40B1214
SXT114	2031F	50351	UET114	N/A	AT20A1123
SXT115	4031F	50354	UET115	90-T40F3	AT40A1121, AT40A1139, AT40B1214
SXT116	4011F	50352	N/A	90-T40F1	AT40A1121, AT40B1206
SXT160	6021F	50316	UET160	N/A	N/A
SXT79R	7541C	50321	UET79R	90-T75C3	AT88A1005, AT88A1021, AT88A1047
SXT100R	10041C	50341	UET100R	N/A	N/A

### Multi-Mount

PART NO.	JARD PART NO.	MARS PART NO.	UEI PART NO.	WHITE-RODGERS PART NO.	HONEYWELL PART NO.
SXT106	4031M	50304	N/A	90-T40M3	AT40A1018, AT72D1683, AT72D1691, AT140A1018
SXT111	5032M	50333	UET111	N/A	N/A
SXT112	4011M	50302	UET112	90-T40M1	AT72D1683, AT140A1000
SXT113	4021M	50303	UET113	90-T40M2	AT72D1691, AT140A1026
SXT148	5032M	50333	N/A	N/A	N/A
SXT150	5031M	50314	UET150	90-T50M3	AT87A1106, AT87A1007, AT87A1049, AT87A1056, AT150A1007

# Sequencers

**THERMODISC**

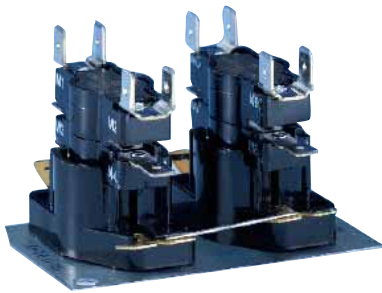

## Features/Benefits

- Direct replacement for most fan & heat sequencing functions.
- 24 volt input control
- Contacts designated M1 – M2 of a multi timing sequencer will turn on first and turn off last, as required by UL and CSA for electric heating applications.
- Five second on delay between all subsequent stages, unless they function together.

## Applications

- The SUPCO Q Series Thermodisc Sequencers are field proven for controlling the operation of heating elements and/or blower motors in electric, gas or oil heat systems.
- Electric Furnaces
  - Heat Pumps
  - Gas Furnaces
  - Oil Furnaces

## Recommended Sequencer Packages for Electric Heating

**Note 1:** Auxiliary Contacts: In the above recommended packages, during the ON cycle, the auxiliary contacts complete the control circuit to subsequent 15S sequencers when more than one 15S sequencer is required. The auxiliary contacts may be any contacts in the first 15S sequencer except those marked M1-M2.

**Note 2:** Fan Interlock: The recommended combinations which contain more than one 15S sequencer include an extra set of contacts for fan interlock. (These are the first contacts of the second and third 15S sequencers.) A fan interlock is required by Underwriters Laboratories in order to guarantee that the fan will stay on until all elements are de-energized. All of the M1-M2 contacts of each 15S unit would be wired to the fan so that during the OFF cycle, the fan would stay energized regardless of the timing sequence of each package.

**Note 3:** Main Contacts, Electrical Ratings: 7FLA, 4LRA, 240 VAC inductive or 30A, 240 VAC resistive or 30A, 240 VAC total of inductive or resistive, with 7FLA, 240 VAC maximum inductive.

**Note 4:** Control Voltage on Heater Terminals (H): 24 VAC nominal (heater rated for 30 VAC/NEMA Class II circuit).

## “Q” Series Sequencer Wiring Diagram

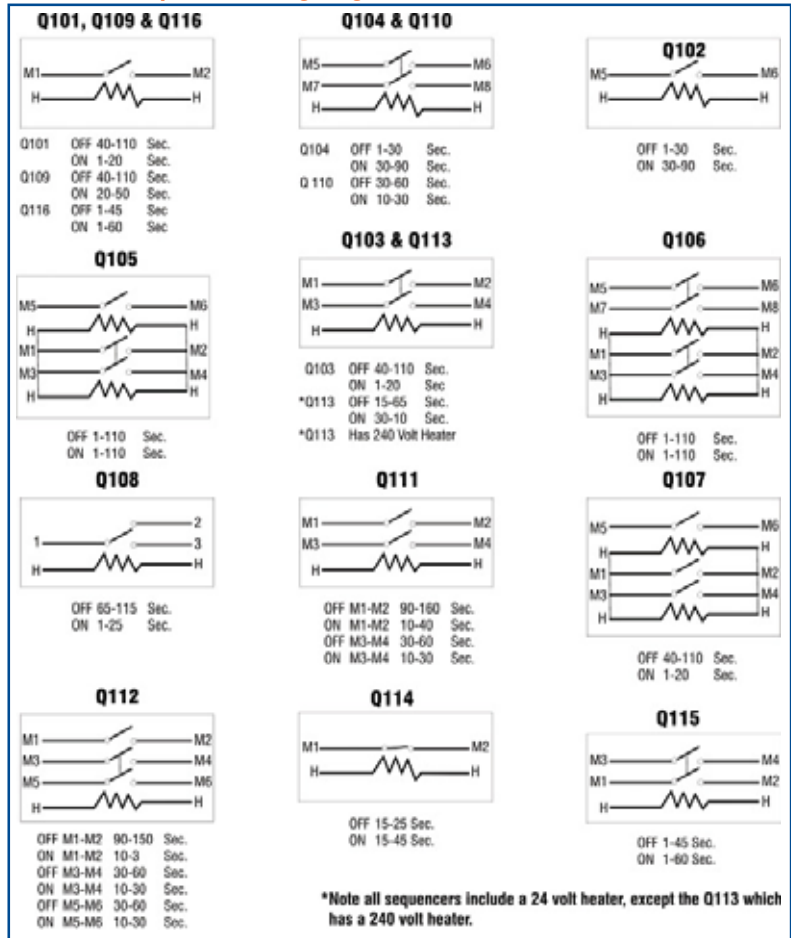

## Cross Reference

PART NO.	GEM	GLOBAL	MARS	WATSCO	KLIXON	W/R	INTERSTATE ELECTRIC I-9	ZETTLER	OEM
Q101	GS101	24ZC-1	33241	TDR10	6000AONI-98	24A34-1	IES24A34-1	ZC24A34-1	***
Q102	GS102	24ZC-2	33242	TDR15	6000AONI-97	24A34-2	IES24A34-2	ZC24A34-2	***
Q103	GS103	24ZC-3	33244	TDR20	6000AONI-87	24A34-3	IES24A34-3	ZC24A34-3	Janitrol BT1256504 ICP/Carrier HQ1056789
Q104	GS104	24ZC-4	33245	TDR25	6000AONI-86	24A34-4	IES24A34-4	ZC24A34-4	***
Q105	GS105	24ZC-5	33232	TDR30	51172-32	24A34-5	IES24A34-5	ZC24A34-5	***
Q106	GS106	24ZC-6	33233	***	51172-22	24A34-6	IES24A34-6	ZC24A34-6	***
Q107	GS107	***	***	***	***	***	***	***	***
Q108	GS108	***	***	***	***	***	***	***	Goodman B13707-38
Q109	***	***	***	***	***	***	***	***	Janitrol BT1256500
Q110	***	***	***	***	***	***	***	***	Weatherking 422311608
Q111	***	***	***	***	***	***	***	***	Weatherking 422311606
Q112	***	***	***	***	***	***	***	***	Weatherking 422311607
Q113	***	***	33265	***	6000E4	***	***	***	***
Q114	***	***	***	***	***	***	***	***	Coleman 7670-307,308 308,130,913,101
Q115	***	***	33246	***	6000EOM	24A52-1	***	***	***
Q116	***	***	33243	***	6000AOM	24A51-1	***	***	***

\*Note all sequencers include a 24 volt heater, except the Q113 which has a 240 volt heater.

# Thermostats



## Gas Furnace Limits and Plenum Thermostats

**THERMODISC**

- Direct OEM Replacements
- Economical
- Use 36T Electrical Ratings (page 42)



### Plenum Thermostats

PART NO.	DESCRIPTION	OPEN °F	CLOSE °F	BOARD WIDTH	BOARD HEIGHT	INSERTION LENGTH	BYP BRYANT DAY & NIGHT PAYNE	CARRIER JANITROL GMC	GOODMAN	LENNOX	YORK	
									AIR-EASE ARMSTRONG CONCORD MAGIC CHEF	CORSAIR RUUD WEATHER KING	RHEEM TRANE GE	BORG-WARNER FRAZIER JOHNSON LUXAIR
SHL501	L170-40 SPST	170°F	130°F	1.88"	2.8"	3.12"	HH12ZA174A HH12ZA176A P331-2203					
SHL502	L180-30 SPST	180°F	150°F	1.88"	2.8"	3.12"	HH12ZA178A	B1370001				
SHL503	L190-40 SPST	190°F	150°F	1.88"	2.8"	3.12"	HH12ZA189 HH12ZB190 HH12ZA193A P331-2205					
SHL504	L240-40 SPST	240°F	200°F	1.88"	2.8"	3.12"	HH12ZA240 HH12ZA252A P331-2217					
SHL505	L140-40 SPST	140°F	100°F	1.88"	2.8"	1.87"	HH12ZB140					025-29041-005
SHL506	L170-40 SPST	170°F	130°F	1.88"	2.8"	1.87"	HH12ZB170			47-25349-02	SWT1258	
SHL507	L140-30 SPST	140°F	110°F	1.88"	2.8"	3.12"	HH12ZA140		87F16			025-29041-005
SHL508	L190-20 SPST	190°F	170°F	1.88"	2.8"	3.12"	HH12ZB190 HH12ZA193 HH12ZA189 P331-2005	B1370913		47-21711-03	SWT1260	025-29041-006
SHL509	L240-30 SPST	240°F	210°F	1.88"	2.8"	3.12"	HH12ZB240 HH12ZA240 HH12ZA252 P331-2217	B1370903				
*SHL510	L150-20 SPST	150°F	130°F	1.625"	1.44"	3.12"	HH12ZB150			47-25349-03		
*SHL511	L160-20 SPST	160°F	140°F	1.625"	1.44"	3.12"	HH12ZB160	1370908S		47-21711-07		
*SHL512	L170-20 SPST	170°F	150°F	1.625"	1.44"	3.12"	HH12ZB170			47-25350-06		
*SHL513	L170-40 SPST	170°F	130°F	1.88"	2.94"	3.12"	HH12ZB170		26H66		SWT1258	
*SHL514	L180-40 SPST	180°F	140°F	1.88"	2.94"	3.12"	HH12ZB180		37H73			
*SHL515	L200-40 SPST	200°F	160°F	1.88"	2.94"	3.12"	HH12ZB200 HH12ZA199 HH12ZA201		49L03	47-25349-05	SWT1260	025-29041-006
*SHL516	L210-40 SPST	210°F	170°F	1.88"	2.94"	3.12"	HH12ZB210					
*SHL517	L220-40 SPST	220°F	180°F	1.88"	2.94"	3.12"	HH12ZB220 HH12ZA219 HH12ZA223 48NHT042 620BE 0122				SWT1273	
*SHL518	L250-40 SPST	250°F	210°F	1.88"	2.94"	3.12"	HH12ZB250 HH12ZA251 P331-2208	B1370012S			SWT1261 SWT1272	
SHL519	L155-30 SPST	155°F	125°F	1.88"	2.8"	7.12"		B1370006 B1370908S				

\* Includes gasket

### Manual Reset Limit Control\* - Open on Rise



PART NO.	DESCRIPTION	OPEN	CLOSE	PART NO.	DESCRIPTION	OPEN	CLOSE
SHM125	Limit - Open on Rise	125	Manual	SHM190	Limit - Open on Rise	190	Manual
SHM130	Limit - Open on Rise	130	Manual	SHM200	Limit - Open on Rise	200	Manual
SHM160	Limit - Open on Rise	160	Manual	SHM290	Limit - Open on Rise	290	Manual
SHM170	Limit - Open on Rise	170	Manual	SHM350	Limit - Open on Rise	350	Manual
SHM180	Limit - Open on Rise	180	Manual				

\* Adapter Flange Plate included with each thermostat. \* Use 60T Electrical Ratings (page 42)

# Thermostats

## Rollout Switches

**THERMODISC**

### Features/Benefits

- Auto and Manual Reset
- Offered in a broad temperature range to cover most heating applications

### Applications

- Automatic or Manual Rollout safety in gas fired furnaces, unit heater and roof top units.



### Small Flush Mount SPST Limit Thermostats (Flush Mount Automatic Rollout)

PART NO.	TERMINALS	CUT OUT	CUT IN	DIFFERENTIAL
SLF130VA	Vertical 1/4"	130	115	15
SLF155VA	Vertical 1/4"	155	115	40
SLF158VB	Vertical 3/16"	158	118	40
SLF165VA	Vertical 1/4"	165	125	40
SLF170VA	Vertical 1/4"	170	130	40
SLF185VB	Vertical 3/16"	185	145	40
SLF190HA	Horizontal 1/4"	190	150	40
SLF194HB	Horizontal 3/16"	194	154	40
SLF194VB	Vertical 3/16"	194	154	40
SLF200HA	Horizontal 1/4"	200	160	40
SLF200VA	Vertical 1/4"	200	160	40
SLF210HA	Horizontal 1/4"	210	170	40
SLF222-VA	Vertical 1/4"	222	182	40

### Small Flush Mount SPST Limit Thermostats (Flush Mount Automatic Rollout)

PART NO.	TERMINALS	CUT OUT	CUT IN	DIFFERENTIAL
SLF230HA	Horizontal 1/4"	230	190	40
SLF230HB	Horizontal 3/16"	230	190	40
SLF250HA	Horizontal 1/4"	250	200	50
SLF252VB	Vertical 3/16"	252	202	50
SLF255VA	Vertical 1/4"	255	205	50
SLF260HA	Horizontal 1/4"	260	210	50
SLF275HB	Horizontal 3/16"	275	225	50
SLF275VB	Vertical 3/16"	275	225	50
SLF280HB	Horizontal 3/16"	280	230	50
SLF300HB	Horizontal 3/16"	300	250	50
SLF300VA	Vertical 1/4"	300	250	50
SLF330VA	Vertical 1/4"	330	280	50

\* Use 36T Electrical Ratings Page 42



### Automatic Rollouts - SPST Limit Thermostats

PART NO.	TERMINALS	CUT OUT	CUT IN	DIFFERENTIAL
SLS120	45° angle 1/4"	120	105	15
SLS130	45° angle 1/4"	130	115	15
SLS140	45° angle 1/4"	140	100	40
SLS145	45° angle 1/4"	145	105	40
SLS150	45° angle 1/4"	150	110	40
SLS155	45° angle 1/4"	155	115	40
SLS160	45° angle 1/4"	160	120	40
SLS165	45° angle 1/4"	165	125	40
SLS170	45° angle 1/4"	170	130	40
SLS175	45° angle 1/4"	175	135	40
SLS180	45° angle 1/4"	180	140	40

### Automatic Rollouts - SPST Limit Thermostats

PART NO.	TERMINALS	CUT OUT	CUT IN	DIFFERENTIAL
SLS200	45° angle 1/4"	200	160	40
SLS250	45° angle 1/4"	250	200	50
SLS255	45° angle 1/4"	255	205	50
SLS265	45° angle 1/4"	265	215	50
SLS275	45° angle 1/4"	275	225	50
SLS285	45° angle 1/4"	285	235	50
SLS295	45° angle 1/4"	295	245	50
SLS300	45° angle 1/4"	300	250	50
SLS300HB	Horizontal 3/16"	300	250	50
SLS350	45° angle 1/4"	350	300	50

\* Use 36T Electrical Ratings Page 42



### Manual Rollouts - SPST Limit Thermostats

PART NO.	TERMINALS	CUT OUT	CUT IN	PART NO.	TERMINALS	CUT OUT	CUT IN
SRL130	Vertical 1/4"	130	Manual	SRL250	Vertical 1/4"	250	Manual
SRL135	Vertical 1/4"	135	Manual	SRL260	Vertical 1/4"	260	Manual
SRL220	Vertical 1/4"	220	Manual	SRL300	Vertical 1/4"	300	Manual
SRL230	Vertical 1/4"	230	Manual	SRL350	Vertical 1/4"	350	Manual
SRL240	Vertical 1/4"	240	Manual	SRL300ICP		300	Manual

\* Use 36T Electrical Ratings Page 43

### SRL Series X Ref

PART NO.	REPLACES OEM	OEM P/N	PART NO.	REPLACES OEM	OEM P/N
SRL130	Rheem/Ruud Weatherking	47-22453-01	SRL260	Nordyne	626350
SRL135	Rheem/Ruud Weatherking	47-22453-02	SRL300	Nordyne	626343
SRL220	Nordyne	626354		Rheem/Ruud Weatherking	47-22861-02
SRL230	Nordyne	626353	SRL300ICP	ICP	1013102
SRL240	Nordyne	626355	SRL350	Goodman	B13701-54
SRL250	Nordyne	626352			

\* Use 36T Electrical Ratings Page 42



### HVAC Flush Mount Adjustable Airstream Thermostats

PART NO.	5/16" AIRSTREAM INSERT	ADJUSTABLE RANGE	DIFFERENTIAL	BRAND	GEM NO.
HF757	Fan Close on Rise	70 180	30	White Rodgers	757-1
HL758	Limit Open on Rise	110 200	30	White Rodgers Carrier	758-1 HH680316

# Thermostats

**THERMODISC™**



AT

## Adjustable AT Series

- Series covers almost 95% of heater and dryer applications
- Dial knob
- 40° adjustable range

- 1/4" quick connect terminals
- Use 60T Electrical Ratings (page 42)

## Adjustable Thermostats

PART NO.	ADJUSTABLE		
	STANDARD MOUNT	RANGE	DIFFERENTIAL
AT012	135	175	40
AT013	175	215	40
AT014	210	250	40
AT015	250	290	40

Open on temperature rise

## Adjustable Airflow Thermostats

PART NO.	ADJUSTABLE		
	STANDARD MOUNT	RANGE	DIFFERENTIAL
AT021	90	130	40
AT022	140	180	40

Close on temperature rise

## Fan Control\* - Close on Rise



SHF

SHL

PART NO.	DESCRIPTION	CUT		DIFFERENTIAL
		OUT	IN	
SHF90	Fan	80	90	10
SHF110	Fan	90	110	20
SHF110DC	Fan - Deep Cup	90	110	20
SHF120	Fan	110	120	10
SHF130	Fan	115	130	15
SHF140	Fan	120	140	20
SHF150	Fan	130	150	20
SHF160	Fan	140	160	20
SHF170	Fan	150	170	20
SHF180	Fan	160	180	20
SHF200	Fan	180	200	20
SHF250	Fan	220	250	30

\*Adapter Flange Plate included with each thermostat.

\*Use 60T Electrical Ratings Page 42

## Limit Control\* - Open on Rise

PART NO.	DESCRIPTION	CUT		DIFFERENTIAL
		OUT	IN	
SHL120	Limit - Open on Rise	120	110	10
SHL140	Limit - Open on Rise	140	100	40
SHL150	Limit - Open on Rise	150	110	40
SHL160	Limit - Open on Rise	160	120	40
SHL170	Limit - Open on Rise	170	130	40
SHL180	Limit - Open on Rise	180	140	40
SHL190	Limit - Open on Rise	190	150	40
SHL200	Limit - Open on Rise	200	160	40
SHL210	Limit - Open on Rise	210	130	80
SHL230	Limit - Open on Rise	230	190	40
SHL250	Limit - Open on Rise	250	210	40
SHL300	Limit - Open on Rise	300	250	50
SHL325	Limit - Open on Rise	325	275	50

\*Adapter Flange Plate included with each thermostat.

\*Use 60T Electrical Ratings Page 42

## Deep Cup Limit Thermostats



35DC

PART NO.	RANGE		DIFFERENTIAL	BRAND	OEM NO.
	OPEN °F	CLOSE °F			
L135DC	135	120	15	Electrolux	5308013213
L145DC	145	125	20	Electrolux	5308015847
L210DC	210	170	40	Armstrong	01851A-025 18J37 1851A 18J3701

\*Use 60T Electrical Ratings Page 42



FL50

## HVAC Flush Mount Staging Thermostats

PART NO.	DESCRIPTION	ADJUSTABLE		
		OPEN	CLOSE	DIFFERENTIAL
FL50	HVAC Staging Thermostat	50	35	15
FL60	HVAC Staging Thermostat	60	45	15

# Thermostats

**THERMODISC**

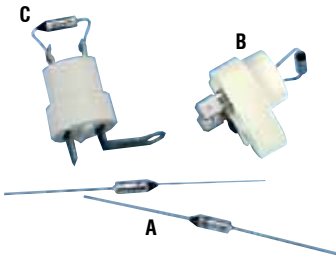

## Thermal Cut Outs

PART NO.		OPEN TEMP.		OPEN TEMP.	PART NO.		OPEN TEMP.		OPEN TEMP.
15 AMP	25 AMP	°C	°F	°F	15 AMP	25 Amp	°C	°F	°F
SERIES 1	SERIES 2			STYLE	SERIES 1	SERIES 2			STYLE
STC4162	STC8162	72	162	A	STC4358		184	363	A
STC4170	STC8170	77	170	A	STC4438	STC8438	226	438	A
STC4183	STC8183	84	183	A	STC4468	STC8468	242	468	A
STC4199	STC8199	93	199	A	STC5257	STC85257	125	257	B
STC4208	STC8208	98	208	A	STC5283	STC85283	139	283	B
STC4220	STC8220	104	220	A	STC5300	STC85300	149	300	B
STC4228	STC8228	109	228	A	STC5333	STC85333	167	333	B
STC4242	STC8242	117	242	A	STC5377	STC85377	192	377	B
STC4250	STC8250	121	250	A	STC6257	STC86257	125	257	C
STC4257	STC8257	125	257	A	STC6283	STC86283	139	283	C
STC4283	STC8283	139	283	A	STC6300	STC86300	149	300	C
STC4300	STC8300	149	300	A	STC6333	STC86333	167	333	C
STC4333		167	333	A	STC6377	STC86377	192	377	C
	STC8378	192	378	A					

Series 1 Maximum Wattage 1800W @ 120V / 2400W @ 240  
Series 2 Maximum Wattage 1800W @ 120V / 6000W @ 240



## Thermal Cut Outs

PART NO.	TERMINALS	°C	°F	STYLE	PART NO.	TERMINALS	°C	°F	STYLE
STF4170	QC. 1/4"	77	170	36T	STF4249B	QC. 3/16"	121	249	36T
STF4183	QC. 1/4"	84	183	36T	STF4262	QC. 1/4"	128	262	36T
STF4208	QC. 1/4"	98	208	36T	STF4291B	QC. 3/16"	144	291	36T
STF4221	QC. 1/4"	105	221	36T	STF4305	QC. 1/4"	152	305	36T
STF4230	QC. 1/4"	110	230	36T	STF4305B	QC. 3/16"	152	305	36T
STF4242	QC. 1/4"	117	242	36T					

\*Maximum Wattage 1800W @ 120V/2400W @ 240

## Exact Replacement Commercial Refrigeration Defrost Thermostats

## Exact Replacement Commercial Refrigeration Defrost Thermostats



- Surface Mount
- 2 wire heater limit 75°F - 40°F range
- SPST
- Resistive Amps: 25
- Volts AC: 120/240

PART NO.	OPEN	CLOSE	MOUNT	REPLACES
SL5708	75°F	40°F	Surface	Bohn, Larkin, Chandler, Climate Control 5708L & 4752C



- Surface Mount
- 3 wire fan and defrost terminator 55°F - 35°F range
- SPDT
- Resistive Amps: 25
- Volts AC: 120/240

PART NO.	OPEN	CLOSE	MOUNT	REPLACES
SL5709	55°F	35°F	Surface	Bohn, Larkin, Chandler, Climate Control 5709L & 4751C



- Tube Mount
- 3 wire defrost control 55°F - 35°F range
- SPDT
- Resistive Amps: 25
- Volts AC: 120/240

PART NO.	OPEN	CLOSE	MOUNT	REPLACES
SL79002	55°F	30°F	Tube	Russell 103079002



- Surface Mount
- 3 wire defrost control 45°F - 30°F range
- SPDT
- Restrictive Amps: 25
- Volts AC: 120/240

PART NO.	OPEN	CLOSE	MOUNT	REPLACES
SL79005	65°F	30°F	Surface	Russell 103079005

# Thermostats

**THERMODISC**



## Flush Mount SPST Thermostats

PART NO.	DESCRIPTION	OPEN	CLOSE	DIFFERENTIAL	BRAND	REFERENCE
FL135	Flush Mount SPST	135	120	15	Whirlpool	295419
					Maytag	C2735801
FL15020	Flush Mount SPST	150	110	20	Maytag	302850
FL15040	Flush Mount SPST	150	110	40	Maytag	302850
FL155	Flush Mount SPST	155	125	30	Maytag	303036
						305865
FL190	Flush Mount SPST	190	180	10	Maytag	300858
FL200	Flush Mount SPST	200	160	40	Electrolux	5308015856
					Franklin	F136204
					Whirlpool	688474
FL205	Flush Mount SPST	205	165	40	Electrolux	5308013695
						5308950121
					Maytag	303396
						338471
					Whirlpool	279048
FL220	Flush Mount SPST	220	180	40	Maytag	301451
						303395
FL225	Flush Mount SPST	225	185	40	Maytag	62641
						510701
FL240	Flush Mount SPST	240	190	50	Maytag	305169
FL260	Flush Mount SPST	260	210	50	GE	WE4X5099
						WE4X5176
					Whirlpool	4452223
FL285	Flush Mount SPST	285	235	50	Electrolux	5303281113
FL320	Flush Mount SPST	320	270	50	Electrolux	5307531201
						7525560
FL350-50	Flush Mount SPST	350	300	50	Maytag	40113801

\*Use 60T Electrical Ratings Page 42



## Flush Mount SPDT Thermostats

PART NO.	DESCRIPTION	OPEN	CLOSE	DIFFERENTIAL	BRAND	REFERENCE
FLD135	Flush Mount SPDT	135	120	15	Maytag	61372M
						R099113
FLD205	Flush Mount SPDT	205	165	40	Whirlpool	279048
						341247
						660036

\*Use 60T Electrical Ratings Page 42



## SFPC Freeze Protection Control

- Protects air conditioning evaporator coil from freezing.
- Opens 35°F/Close 50°F
- Fits 7/8" O.D. Tubing
- Replaces: Trol-A-Temp FPC
- Includes clip to fit 7/8" O.D. tubing

# Thermostats

**THERMODISC**

## General Purpose L & LD Series



- Open on rise
- Close when temperature differential is reached
- 1/4" quick disconnect terminals

### Applications

- Most home laundry dryers
- Fan and Limit Applications



## "L" Series, Single Pole - Single Throw

PART NO.				PART NO.				
°DIFF.	OPEN (°F)	CLOSE (°F)	°DIFF.	OPEN (°F)	CLOSE (°F)	°DIFF.	OPEN (°F)	CLOSE (°F)
L120	10	120	110	L190	40	190	150	
L125	10	125	115	L200	40	200	160	
L130	15	130	115	L205	40	205	165	
L135	15	135	120	L225	40	225	185	
L140	20	140	120	L240	40	240	200	
L145	20	145	125	L250	40	250	210	
L150	20	150	130	L260	40	260	220	
L155	20	155	135	L270	40	270	230	
L160	20	160	140	L290	40	290	250	
L165	20	165	145	L300	40	300	260	
L170	20	170	150	L320	40	320	280	
L175	20	175	155	L340	40	340	300	
L180-20	20	180	160					
L180-40	40	180	140					

Use 60T Electrical Ratings Below

## "LD" Series, Single Pole - Double Pole



PART NO.	DESCRIPTION	OPEN	CLOSE	DIFFERENTIAL
LD120	SPDT Thermostats	120	105	15
LD130	SPDT Thermostats	130	115	15
LD135	SPDT Thermostats	135	120	15
LD140	SPDT Thermostats	140	120	20
LD145	SPDT Thermostats	145	125	20
LD155	SPDT Thermostats	155	135	20
LD170	SPDT Thermostats	170	150	20
LD190	SPDT Thermostats	190	170	20
LD200	SPDT Thermostats	200	160	40
LD210	SPDT Thermostats	210	170	40
LD225	SPDT Thermostats	225	185	40
LD240	SPDT Thermostats	240	200	40
LD270	SPDT Thermostats	270	230	40
LD290	SPDT Thermostats	290	250	40
LD305	SPDT Thermostats	305	265	40

Use 60T Electrical Ratings Below

## Terminal Adapters



T1121



T1124



T1122



T1125



T1123

PART NO.	DESCRIPTION	WHERE USED
T1121	2 to 1 Terminal Adapter	1/4" QC Female to 2 Male 1/4" QC Chair Terminal
T1122	2 to 1 Terminal Adapter	1/4" QC Female to 2 Male 1/4" QC Side by Side Terminal
T1123	Screw to Terminal Adapter	8 - 10 Stud to 1/4" QC Terminal
T1124	Terminal to Screw Adapter	1/4" QC Female to Screw Right Angle Terminal
T1125	2 to 1 Terminal Adapter	1/4" QC Female to 1/4" QC Male Piggyback Terminal

## Typical Electrical Ratings

### 36T Electrical Ratings

VAC	Resistive (Non-Inductive)	Motor Rating (Inductive)		Pilot Duty
		Full Load	Locked Rotor	
120	15A	3A	12A	125 VA
240	10A	1.5A	6A	125 VA

350°F Max Ambient Temperature

### 60T Electrical Ratings

VAC	Resistive (Non-Inductive)	Motor Rating (Inductive)		Pilot Duty
		Full Load	Locked Rotor	
120	25A	14A	72A	125 VA
240	25A	10A	60A	125 VA

350°F Max Ambient Temperature

# Furnace Igniters



## IG Series Flat Hot Surface Furnace Igniters

SUPCO's IG series flat hot surface igniters offer dependable ignition in all heating applications; including furnaces, boilers, rooftops, unit heaters, water heaters, swimming pool heaters and many other types of heating equipment. The SUPCO Flat Igniters offer an efficient, stronger more reliable hot surface Silicon Carbide (SiC) composition that uses a unique manufacturing process, compared to the existing Silicon Carbide design that has been used in heating equipment for years.

### Specifications

- Time to temperature (1800° F): <17 seconds @ 102 VAC
- Voltage: 120 VAC
- Amperage: 3.5 – 5 AMPS @ 132 VAC maximum
- Cold Resistance: 40 - 100 OHMS @ 75°F +/- 10°F

### Features/Benefits

- Faster time to temperature response
- Stronger more durable design
- More robust in transit
- Higher resistance to oxidation
- Prolonged life
- 18 gauge nickel copper high temperature fiberglass insulated lead wires
- All kits include the necessary hardware, instructions (where applicable) and cross reference information for easy installation.
- Lower power consumption
- Superior gas lighting ability

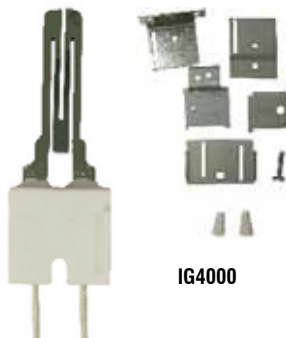

IG4000



IG402K



IG403K



IG401



IG405



IG406



IG412



IG414

### Product Information

UNIVERSAL KITS	ROBERTSHAW	CERAMIC BLOCK	TERMINAL CONNECTOR
IG4000	41-402	W	N/A
	41-403	M	N/A
	41-404	M	D
	41-405	D	N/A
	41-407	M	B
	41-408	W	C
	41-409	M	D
	41-410	W	B
	41-412	NM	D
	41-414	NM	D
	41-1090	W	N/A
	41-238	W	N/A
	41-242	W	N/A
IG402K	41-402	W	N/A
	41-408	W	C
	41-410	W	B
	41-411	W	C
IG403K	41-403	M	N/A
	41-404	M	D
	41-407	M	B
	41-409	M	D
<b>EXACT KITS</b>			
IG401	41-401	A	A
IG405	41-405	D	N/A
IG406	41-406	Y	N/A
IG412	41-412	NM	D
IG414	41-414	NM	D

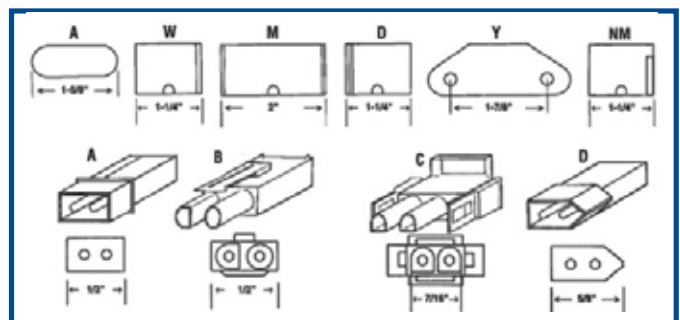

# Furnace Igniters

## IG402K Cross Reference

OEM	P/N	Robertshaw P/N	Exact	Functional
American Road Equipment	201W	41-402		X
Armstrong Air	38322B001	41-402		X
Claire Brothers	C-238	41-402		X
Claire Brothers	C-242	41-402		X
Coleman	1474-051	41-402		X
Coleman	1474-052	41-402		X
DMO Industries	20834	41-402		X
Dornback Furnace	271 W	41-402		X
Enerco Tech	10399	41-402		X
Evcon	1474-051	41-402		X
Evcon	1474-052	41-402		X
HUPP Industries	9050	41-402		X
Majestic	75-92-104	41-402		X
Majestic	75-92-105	41-402		X
Metzger	201N	41-402		X
Metzger	201W	41-402		X
Mor Flo	3200618	41-402		X
Nordyne	105141000	41-402		X
Nordyne	632-0880	41-402		X
Nordyne	632-0770	41-402		X
Norton	201K	41-402		X
Norton	201L	41-402		X
Norton	201N	41-402		X
Norton	201R	41-402		X
Norton	201W	41-402		X
Norton	271N	41-402		X
Norton	271W	41-402		X
Rheem	62-22441-01	41-408	X	
Rheem	62-22441-01	41-402		X
Rheem	62-22868-02	41-411	X	
Rheem	62-22868-82	41-411	X	
Rheem	62-22868-93	41-411	X	
Rheem	62-22868-2	41-411	X	
Roberts Gordon	90436600	41-402		X
Superior Fireplace	94851	41-402		X
Trane Company	B144676P01	41-410	X	
Trane Company	B340039P01	41-408	X	
Trane Company	340039P01	41-402		X
Trane Company	IGN23	41-402		X
Trane Company	IGN34	41-408	X	
Wayne Home Equipment	62821-001	41-402		X
Wayne Home Equipment	62821-002	41-402		X
White, LB	120-07549	41-402		X
White LB Company	120-07549	41-402		X
White Rodgers	767A-357	41-402		X
White Rodgers	767A-365	41-402		X
White Rodgers	767A-366	41-402		X
White Rodgers	767A-377	41-408		X
Williamson	9050	41-402		X

## IG403K Cross Reference

OEM	P/N	Robertshaw	Exact	Functional
Carrier Corp	LH33ZS001A	41-409	X	
Carrier Corp	LH33ZS002	41-409	X	
Ducane	20015201	41-409	X	
Norton	201	41-403		X
Norton	271	41-403		X
Raypak	600915	41-403		X
Roberts Gordon	90434300	41-409		X
Snyder General	1380672	41-409	X	
Snyder General	1380680	41-409	X	
Snyder General	1380654	41-403		X
Trane Company	B138196P01	41-403		X
Trane Company	IGN26	41-409	X	
Trane Company	IGN26	41-403		X
Trane Company	IGN30	41-407	X	
Trane Company	IGN30	41-403		X
Weil Mclain	511-330-139	41-409	X	
Weil Mclain	511-330-193	41-403		X
Weil Mclain	511-330-190	41-404	X	

## Supco Flat Igniter Cross Reference

PART NO.	OEM P/N	OEM P/N	Robertshaw P/N	Exact	Functional
IG401	Amana	B1336102	41-401	X	
IG401	Amana	D99182	41-401	X	
IG401	Amana	10041601	41-401	X	
IG401	Norton	201A	41-401	X	
IG401	Norton	271A	41-401	X	
IG401	Trianco-Heatmaker	2600-359	41-401	X	
IG401	White Rodgers	767A309	41-401	X	
IG401	White Rodgers	767A356	41-401	X	
IG405	Detroit Radiant	201D	41-405	X	
IG405	Norton	201D	41-405	X	
IG405	Norton	271P	41-405	X	
IG405	Smith HB	50018	41-405	X	
IG405	Viessman	9302094	41-405	X	
IG405	White Rodgers	767A361	41-405	X	
IG405	York International	025-27766-000	41-405	X	
IG405	York International	025-27774-000	41-405	X	
IG405	York International	025-29043-000	41-405	X	
IG405	York International	025-29050-000	41-405	X	
IG405	White Rogers	767A-361	41-405	X	
IG406	American Appliance	271B	41-406	X	
IG406	Comfort Zone	150114-04-01	41-406	X	
IG406	Mor Flo	3200580	41-406	X	
IG406	Mor Flo	3210401	41-406	X	
IG406	Norton	201J	41-406	X	
IG406	Norton	201M	41-406	X	
IG406	Norton	201N	41-406	X	X
IG406	Norton	201Y	41-406	X	
IG406	Norton	271M	41-406	X	
IG406	Norton	271Y	41-406	X	
IG406	Perfection Schwank	108803-G1	41-406	X	
IG406	Weil Mclain	511-330-188	41-406	X	
IG406	Weil Mclain	511-330-148	41-406	X	
IG406	White Rogers	767A-374			
IG412	Goodman	B1401009S	41-412	X	
IG412	Goodman	B1401009	41-412	X	
IG412	Intercity Products	1009604	41-412	X	
IG412	White Rogers	767A-373	410412	X	
IG414	Arcoaire	1096048	41-414	X	
IG414	Arcoaire	1380680	41-414	X	
IG414	Comfortmaker	1096048	41-414	X	
IG414	Heil	1096048	41-414	X	
IG414	Intercity Products	1096048	41-414	X	
IG414	Norton	271NM	41-414	X	
IG414	Tempstar	1096048	41-414	X	
IG414	White Rogers	767A-384	41-414	X	

**Note:** Partial Cross Reference. Contact SUPCO for complete Cross Reference.

### Igniter Facts and Fiction

- Fact:** SUPCO's Igniters are made from high density silicon carbide. They are fragile and must be treated with care during installation.
- Fiction:** Handling an igniter with bare hands will cause premature failure.
- Fact:** Premature failure of an igniter can be caused by excess vibration, incorrect voltage or improper installation.
- Fiction:** Round igniter designs cannot be used to replace flat igniters.
- Fact:** By using proper mounting hardware, a round igniter can be used in place of an original flat igniter.
- Fiction:** If the replacement igniter looks the same as the original, it will work in the application.
- Fact:** Igniters differ in their ability to handle current (amps) and each is designed for a specific OEM application. Consult the cross reference information in this catalog sheet to identify the correct replacement.
- Fiction:** Testing for a good igniter is done by measuring its Resistance (Ohms).
- Fact:** The test of an igniter is done by measuring the current draw (amps) of the ignition circuit.
- Fiction:** A visual inspection of an igniter will identify whether it is operable.
- Fact:** Hairline cracks cannot be seen, and will cause improper operation of the igniter. It is recommended to use a current (amp) test.

# Furnace Igniters



## Silicon Nitride Universal Furnace Igniters - 120 Volt

Silicon Nitride (SiNi) igniters offer the ultimate in durability and cycle life. Choose from three (3) Universal 120 V SiNi igniters to upgrade your ignition control system.

### Features/Benefits

- Silicon Nitride technology for strong, durable operation and performance
- Easy installation: kits include igniter, mounting brackets, hardware, instructions & cross reference
- Universal replacements, reduces SKU's
- Replaces hundreds of OEM & competitors igniters
- Longer igniter life (non porous construction)
- Low energy consumption uses half the power
- Low energy consumption uses half the power of Silicon Carbide igniters
- Superior gas lighting ability, faster time to temperature response than Silicon Carbide igniters
- 120 volt full line voltage igniters no power supply module required

### Applications

(Various types of gas fired equipment)

- Furnaces
- Boilers
- Unit Heaters
- Water Heaters

**Note:** Silicon Nitride HSI igniters CANNOT be used in Direct Sense Applications!



SSN4000

### SSN4000 Ultimate Mini Universal Silicon Nitride Igniter-120 Volt

- Miniature design
- Life rated to 200,000 cycles
- 3 year warranty

### Specifications

Operating Voltage	115 VAC Min 102-132 VAC
Time To Temperature	1800°F (982°C) <10 Seconds @ 115 VAC & 75°F ±10°F Ambient
Steady Temperature	2366°F (1297°C)
Cold Resistance	46 Ohms @ 75°F ±10°F
Steady Current	.53Amps @ 115 VAC
High Temperature Wire Leads	6" 20 AWG 572°F (300C) UL1332
Life Cycles	>200,000



SSN3000

### SSN3000 Heavy Duty Universal Silicon Nitride Igniter - 120 Volt

- Robust design
- Life rated to 50,000 cycles
- 2 year warranty

### Specifications for SSN3000/SSN3016

Operating Voltage	115 VAC Min 102-132 VAC
Time To Temperature	1800°F (982°C) <17 Seconds @ 102 VAC & 75°F ±10°F Ambient
Steady Temperature	2366°F (1297°C)
Cold Resistance	10 Ohms @ 75°F ±10°F
Steady Current	<4.25 Amps @ 132 VAC
High Temperature Wire Leads	24" 18 AWG 842°F (450C) UL512B
Life Cycles	>50,000



SSN2000

### SSN2000 Universal Silicon Nitride Igniter - 120 Volt

- Economic design
- Life rated to 50,000 cycles
- 1 year warranty
- CSA Approved

### Specifications

Operating voltage	120 VAC (±10-15%)
Time to 2102°F (1150°C)	<17 seconds @ 120 VAC
Steady temperature	2156°F-2426°F (1180°C-1330°C) @ 120 VAC
Cold resistance	15-30 Ohms @ 77°F (25°C)
Steady current	1.3 Amps (±0.3 Amps @ 120 VAC)
High temperature wire leads	20 AWG UL10362 482°F
Life cycles	>50,000

A universal replacement igniter kit that replaces over 100 igniters and incorporates the durable and energy saving Silicon Nitride (Si3N4) technology.



SSN3016

### SSN3016 Direct Replacement Silicon Nitride Igniter - 120 Volt

- Robust Design
- Stronger Physical Durability
- <17 sec Time to Temp
- Replaces **Goodman** Igniters- B140105, B1401009
- >50,000 cycles
- 2 year warranty

# Furnace Igniters

## SSN4000 Cross Reference

Amana 10735002 10755002 B138196P01 B144676P02 B340039P01 B144676P01 American Standard IGN0030 Arcoaire See ICP Armstrong 383322B001 Barnett Brass 661924 661926 661927 661928 Carrier LH33ZS001A LH33ZS002 LH33ZS003 LH33ZS004 Claire Bros C238 C238-1 C242 Coleman/Evcon 14740511 14740512 Detroit/Brant Radiant 201D	DMO/Olsen ECR Ind 26789 20834 Dornback 271W Ducane 20015201 Enerco Tech 10399 EZ Flow 62374 Hupp Ind 9050 GE/Hot Point WG37X11 WG37X34 Giant PV 526000125 FC067 626000025 GMO 20834 Goodman/Janitrol B1193939 B11726-06 B1401009 Grimsby Stove ZCO-350 John Woods/GSW PV 86483 71082 HB Smith Johnstone	50018 1148245 9050 101344 Heatmaker 2400-048 2400-286 2600-359 3079-100 9330-102 Hupp Ind 9050 ICP/Heil 69P01 Comfortmaker/Arcoaire Tempstar/Keeperite Snyder General 1009980 1096048 1009604 1001344 1380680 1148145 1096047 1380654 1380672 1148245 John Woods/GSW PV 6905332 3260618 Johnstone	L37-698 L37-699 L37-700 L37-812 L37-814 L37-815 L37-816 L40-765 LB White Co 120-07549 Lennox 33J3701 96P01 36N77 98P77 98P78 Majestic 75-92-104 75-92-105 201N 201M 201P 201RS Mor Flo 3200618 Nordyne/Tappan Frigidaire/Philco Intertherm/Miller 903758 201 105141000 RH622286893 Nordyne/Tappan Olsen 26789 Raypack	Frigidaire/Philco Intertherm/Miller 632-0770 632-0880 632245-0 902661 902694 903758 632-3811 632-3540 Norton 101M 96P01 201D 201K 201L 201M 201P 201RS 201W 271N 271R 271RS 271W 271A 201A 271A 201R 201 271NM 201 271 271NM Olsen 26789 Raypack 600915 41-402N 41-403N 41-408N 41-409N 41-412N Starlite	50015 600915 Rheem 62-22441-01 62-22668-93 62-212868-82 62-22868-02 90434300 Roberts Gordon 90436600 Robertshaw/ Uniline 41-402 41-403 41-404 41-405 41-407 41-408 41-409 41-410 41-1090 41-402N 41-403N 41-404N 41-405N 41-407N 41-408N 41-409N 41-410N 41-412N Starlite	11120-100-1402 11120-100-1403 11120-100-1405 11120-100-1407 11120-100-1408 11120-100-1409 Surface Igniter FC007 FC024 FC035 FC046 FC050 FC051 FC055 Superior Fireplace 94851 Temp Controls 9302-094 Trane 3400339P01 B340039P01 B12996P01 B144676P01 B144676P02 B138196P01 IGN21 IGN26 IGN28 IGN30 IGN34 B144676P01 B144676P02 Trane	B138196P01 IGN21 IGN23 IGN26 IGN28 IGN30 IGN34 Trianco Heatmaker 2600-359 Viessmann 9302-093 9302-094 Wayne Home Equipment 62821-001 62821-002 Weil McLain 29074 511-330-139 511-330-193 373-09154-700 Whirlpool 99794323 99794328 White LB Co 120-07549 White Rodgers 29074	767A-301 767A-303 767A-306 767A-309 767A-350 767A-352 767A-353 767A-354 767A-356 767A-364 767A-365 767A-366 767A-370 767A-371 767A-372 Williamson 9050 York 025-32626-000 473-12509-001 373-09154-700 025-27774-000 025-29043-000 025-29050-000 025-27766-000 025-30277-000 025-32638-002 025-32625-000 025-31801-000 373-05342-700 025-27766-000
---	---	---	--	--	---	--	---	---

## SSN3000 Cross Reference

Amana 10735002 10755002 B138196P01 B144676P02 B340039P01 B144676P01 American Appliance 271B American Standard IGN0030 American Water Heater 6905032 Arcoaire See ICP Armstrong 383228001 38322B001 Barnett Brass 661924 661927 661928 Carrier LH33ZS001A LH33ZS002 LH33ZS003 LH33ZS004 Claire Bros C238 C238-1 C242 Coleman/Evcon 14740511 14740512	Detroit/Brant Radiant HB Smith 14740512 201D DMO/Olsen/ECR Ind Hupp Ind 9050 20834 Dornback 271W Ducane 20015201 Enerco Tech 10399 EZ Flow 62374 GE/Hot Point WG37X11 WG37X34 Giant PV 526000125 526000025 GMO Industries 20834 Goodman/Janitrol B1172606 B1193939 B1401009 Grimsby Stove ZCO-350 John Woods/ GSW PV 86483 71082 HB Smith Johnstone	101344 1148245 96P01 36N77 98P77 98P78 Majestic 75-92-104 75-92-105 75-92-104 95-92-105 1096048 1009604 1001344 1380680 1148145 1096047 1380654 1380672 1148245 Integra 6905032 3260618 Johnstone L37-698 L37-699 L37-700 L37-812 L37-814 L37-816 LB White Co 120-07549	Lennox 33J3701 96P01 36N77 98P77 98P78 Majestic 75-92-104 75-92-105 75-92-104 95-92-105 Mars 67930 Metzger 201N 201W Mor-Flo 3200618 Nordyne/Tappan Frigidaire/Philco Intertherm/Miller 903110 105141000 632-0880 902661 902694 903758 632-3811 Norton 101M 201D 201K	Norton 201L 201M 201P 201W 271M 271N 271RS 271W 201A 271A 201R 201 271 271NM Olsen 26789 Raypack 600915 Rheem/Rudd 62-22868-93 62-22441-01 62-22868-82 600915 41-412N Surface Igniter FC007 FC011 FC014 FC018 FC020 FC021 FC022 FC023 FC024 FC025 FC027	Robertshaw/ Uniline 41-238 41-242 41-402 41-403 41-404 41-405 41-407 41-408 41-409 41-410 41-412 41-1090 41-402N 41-403N 41-404N 41-405N 41-407N 41-408N 41-409N 41-410N 41-412N Surface Igniter FC007 FC011 FC014 FC018 FC020 FC021 FC022 FC023 FC024 FC025 FC027	Surface Igniter FC028 FC029 FC030 FC032 FC034 FC035 FC037 FC040 FC041 FC045 FC046 FC048 FC050 FC051 Starlite 11120-100-1402 11120-100-1403 11120-100-1405 11120-100-1407 11120-100-1408 11120-100-1409 Superior Fireplace 94851 Temp Controls 9302-094 Trane 3400339P01 B340039P01 B12996P01 B144676P01 B138196P01 IGN21 IGN26	Trane IGN28 IGN30 IGN34 B144676P01 B144676P02 B138196P01 IGN21 IGN23 IGN26 IGN28 IGN30 IGN34 Trianco Heatmaker 2600-359 Viessmann 9302-093 9302-094 Wayne Home Equipment 62821-001 62821-002 Weil McLain 29074 511-330-139 511-330-193 373-09154-700 Whirlpool 99794323 99794328 White LB Co 120-07549	White Rodgers 767A-301 767A-303 767A-306 767A-309 767A-350 767A-352 767A-353 767A-354 767A-356 767A-364 767A-365 767A-366 767A-370 767A-371 767A-372 Williamson 09050 York 025-32626-000 473-12509-001 373-09154-700 025-27774-000 025-29043-000 025-29050-000 025-27766-000 025-30277-000 025-32638-002 025-32625-000 025-31801-000 373-05342-700 025-27766-000
---	--	--	--	---	--	---	---	---

## SSN2000 Cross Reference

American Appliance 271B American Road Equip 201W Arcoaire 1096048 Carrier Corp 1380680 Armstrong Air 38322B001 Carlin 87197S LH33ZS001A LH33ZS002 Claire Brothers C238 C242 Coleman 1474-051 174-052	Comfortmaker 1096048 Comfort Zone 150114-04-01 Detroit Radiator 201D 20015201 DMO Industries 20834 Dornback Furnace 271W Ducane 20015201 Enerco Tech 10399 Evcon 1474-051 1474-052 Goodman 10401009 B1401018S	HB Smith 50018 Heil 1096048 Hupp Industries 9050 ICP 1009604 1096048 3200618 Igniters Direct HSIURK120V FC007 LB White 120-07549 Majestic 75-92-104 75-92-105	Mars 67930 67931 67932 Metzger 201W Mor Flo 3200618 3210401 Raypak 600915 Rheem 62821-001 62-22868-82 62-22868-93 902661 902694 903110 FC007	Norton 201,201D,201J,201K,201L 201M, 201N, 201R, 201W 201Y, 271, 271D, 271M 271N, 271NM, 271P 271W, 271Y Perfection Schwank 108803-G1 Raypak 600915 Rheem 62821-001 62-22868-82 62-22868-93 902661 902694 903110 FC007	Robertshaw 41-409, 41-410, 41-411 41-412, 41-413, 41-414 Snyder General Tempstar 380654 1380672 1380680 Superior Fireplace 94851 Tempstar 1096048 1148245 Trane 340039P01, B138196P01 B144676P01, B144676P02 B340039P01, IGN21 IGN23, IGN26, IGN30, IGN34 Viessman 9302-094	Wayne Home Equip 62-22441-01 62-22441-02 Weil McLain 511-330-139 511-330-190 511-330-193 White LB Co 120-07549 White Rodgers 21D64-2 767A-301 767A-303 737A-306 767A-310 767A-311 767A-350 767A-353 767A-354	White Rodgers 767A-361 767A-364 767A-365 767A-366 767A-370 767A-371 767A-372 767A-373 767A-374 767A-375 767A-376 767A-377 767A-382 767A-383 767A-384 767A-387 767A-388 767A-389 767A-390 767A-391 767A-392 767A-393 767A-394 767A-395 767A-396 767A-397 767A-398 767A-399 767A-400 767A-401 767A-402 767A-403 767A-404 767A-405 767A-406 767A-407 767A-408 767A-409 767A-410 767A-411 767A-412 767A-413 767A-414 767A-415 767A-416 767A-417 767A-418 767A-419 767A-420 767A-421 767A-422 767A-423 767A-424 767A-425 767A-426 767A-427 767A-428 767A-429 767A-430 767A-431 767A-432 767A-433 767A-434 767A-435 767A-436 767A-437 767A-438 767A-439 767A-440 767A-441 767A-442 767A-443 767A-444 767A-445 767A-446 767A-447 767A-448 767A-449 767A-450 767A-451 767A-452 767A-453 767A-454 767A-455 767A-456 767A-457 767A-458 767A-459 767A-460 767A-461 767A-462 767A-463 767A-464 767A-465 767A-466 767A-467 767A-468 767A-469 767A-470 767A-471 767A-472 767A-473 767A-474 767A-475 767A-476 767A-477 767A-478 767A-479 767A-480 767A-481 767A-482 767A-483 767A-484 767A-485 767A-486 767A-487 767A-488 767A-489 767A-490 767A-491 767A-492 767A-493 767A-494 767A-495 767A-496 767A-497 767A-498 767A-499 767A-500 767A-501 767A-502 767A-503 767A-504 767A-505 767A-506 767A-507 767A-508 767A-509 767A-510 767A-511 767A-512 767A-513 767A-514 767A-515 767A-516 767A-517 767A-518 767A-519 767A-520 767A-521 767A-522 767A-523 767A-524 767A-525 767A-526 767A-527 767A-528 767A-529 767A-530 767A-531 767A-532 767A-533 767A-534 767A-535 767A-536 767A-537 767A-538 767A-539 767A-540 767A-541 767A-542 767A-543 767A-544 767A-545 767A-546 767A-547 767A-548 767A-549 767A-550 767A-551 767A-552 767A-553 767A-554 767A-555 767A-556 767A-557 767A-558 767A-559 767A-560 767A-561 767A-562 767A-563 767A-564 767A-565 767A-566 767A-567 767A-568 767A-569 767A-570 767A-571 767A-572 767A-573 767A-574 767A-575 767A-576 767A-577 767A-578 767A-579 767A-580 767A-581 767A-582 767A-583 767A-584 767A-585 767A-586 767A-587 767A-588 767A-589 767A-590 767A-591 767A-592 767A-593 767A-594 767A-595 767A-596 767A-597 767A-598 767A-599 767A-600 767A-601 767A-602 767A-603 767A-604 767A-605 767A-606 767A-607 767A-608 767A-609 767A-610 767A-611 767A-612 767A-613 767A-614 767A-615 767A-616 767A-617 767A-618 767A-619 767A-620 767A-621 767A-622 767A-623 767A-624 767A-625 767A-626 767A-627 767A-628 767A-629 767A-630 767A-631 767A-632 767A-633 767A-634 767A-635 767A-636 767A-637 767A-638 767A-639 767A-640 767A-641 767A-642 767A-643 767A-644 767A-645 767A-646 767A-647 767A-648 767A-649 767A-650 767A-651 767A-652 767A-653 767A-654 767A-655 767A-656 767A-657 767A-658 767A-659 767A-660 767A-661 767A-662 767A-663 767A-664 767A-665 767A-666 767A-667 767A-668 767A-669 767A-670 767A-671 767A-672 767A-673 767A-674 767A-675 767A-676 767A-677 767A-678 767A-679 767A-680 767A-681 767A-682 767A-683 767A-684 767A-685 767A-686 767A-687 767A-688 767A-689 767A-690 767A-691 767A-692 767A-693 767A-694 767A-695 767A-696 767A-697 767A-698 767A-699 767A-700 767A-701 767A-702 767A-703 767A-704 767A-705 767A-706 767A-707 767A-708 767A-709 767A-710 767A-711 767A-712 767A-713 767A-714 767A-715 767A-716 767A-717 767A-718 767A-719 767A-720 767A-721 767A-722 767A-723 767A-724 767A-725 767A-726 767A-727 767A-728 767A-729 767A-730 767A-731 767A-732 767A-733 767A-734 767A-735 767A-736 767A-737 767A-738 767A-739 767A-740 767A-741 767A-742 767A-743 767A-744 767A-745 767A-746 767A-747 767A-748 767A-749 767A-750 767A-751 767A-752 767A-753 767A-754 767A-755 767A-756 767A-757 767A-758 767A-759 767A-760 767A-761 767A-762 767A-763 767A-764 767A-765 767A-766 767A-767 767A-768 767A-769 767A-770 767A-771 767A-772 767A-773 767A-774 767A-775 767A-776 767A-777 767A-778 767A-779 767A-780 767A-781 767A-782 767A-783 767A-784 767A-785 767A-786 767A-787 767A-788 767A-789 767A-790 767A-791 767A-792 767A-793 767A-794 767A-795 767A-796 767A-797 767A-798 767A-799 767A-800 767A-801 767A-802 767A-803 767A-804 767A-805 767A-806 767A-807 767A-808 767A-809 767A-810 767A-811 767A-812 767A-813 767A-814 767A-815 767A-816 767A-817 767A-818 767A-819 767A-820 767A-821 767A-822 767A-823 767A-824 767A-825 767A-826 767A-827 767A-828 767A-829 767A-830 767A-831 767A-832 767A-833 767A-834 767A-835 767A-836 767A-837 767A-838 767A-839 767A-840 767A-841 767A-842 767A-843 767A-844 767A-845 767A-846 767A-847 767A-848 767A-849 767A-850 767A-851 767A-852 767A-853 767A-854 767A-855 767A-856 767A-857 767A-858 767A-859 767A-860 767A-861 767A-862 767A-863 767A-864 767A-865 767A-866 767A-867 767A-868 767A-869 767A-870 767A-871 767A-872 767A-873 767A-874 767A-875 767A-876 767A-877 767A-878 767A-879 767A-880 767A-881 767A-882 767A-883 767A-884 767A-885 767A-886 767A-887 767A-888 767A-889 767A-890 767A-891 767A-892 767A-893 767A-894 767A-895 767A-896 767A-897 767A-898 767A-899 767A-900 767A-901 767A-902 767A-903 767A-904 767A-905 767A-906 767A-907 767A-908 767A-909 767A-910 767A-911 767A-912 767A-913 767A-914 767A-915 767A-916 767A-917 767A-918 767A-919 767A-920 767A-921 767A-922 767A-923 767A-924 767A-925 767A-926 767A-927 767A-928 767A-929 767A-930 767A-931 767A-932 767A-933 767A-934 767A-935 767A-936 767A-937 767A-938 767A-939 767A-940 767A-941 767A-942 767A-943 767A-944 767A-945 767A-946 767A-947 767A-948 767A-949 767A-950 767A-951 767A-952 767A-953 767A-954 767A-955 767A-956 767A-957 767A-958 767A-959 7
---	---	--	--	---	---	--	--

# Furnace Igniters

## SSN24 - Silicon Nitride Universal 24 VOLT Igniter & Flame Rod Assembly Kit



### Features/Benefits

- Silicon Nitride design for strong, durable operation and performance.
- Low energy consumption.
- Backward compatible with all 24 Volt Honeywell 1st & 2nd generation Smart Valves.
- Specifically used with the Honeywell Smart Valve™
- CSA approved
- Pre-assembled SiNi igniter & Ni Chrome flame rod, mounting clip, instructions and cross reference.

### Applications

- Furnaces, boilers, unit heaters, hot water heaters, fireplaces, pool heaters and spas that utilize the Honeywell Smart Valve.

### Specifications

Operating Voltage	24 VAC + / - 10 - 15 %
Time To Reach 1800 F (982 C)	< 3 Seconds @ 24 VAC
Cold Resistance	4 - 6 Ohms @ 75 F (24 C)
Steady Current	0.8 - 1.2 Amps
Life Cycles	200,000

### Uses & Replacements

Used In Honeywell Smart Valves™	Replaces Flame Rod Assemblies
SV9500	1009524
SV9500M2603	1149856
SV9500M2674	42640001
SV9500M2682	Q3400A
SV9501M2528	Q3400A1016
SV9600	Q3400A1024
SV9600H	Q3400A1040
SV9401	Q3450
SV9402	Q3480
SV9403	Q3620
SV9501	Mars
SV9502	68012
SV9503	Igniters Direct
SV9601	AFN643
SV9602	

## SIG Series Round Furnace Igniters

Utilizing a spiral design, SUPCO's full line of igniters have greater physical strength and longer life. Including mounting hardware, where necessary, direct replacement of original equipment parts is easy (Including round and flat original parts). Choose the igniter for your application. For 115 - 120V applications.

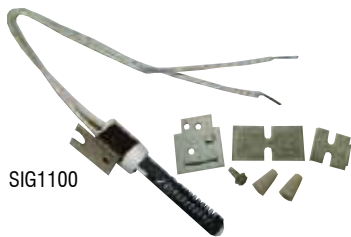

SIG1100

### SIG1100 - Universal Round Furnace Igniter Kit

Designed to replace over 170 part numbers including Robertshaw, Norton and many other original equipment manufacturers.

- Engineered Reaction Bonded Silicon Carbide Design
- Greater Physical Strength
- Lower Power Consumption
- Superior Gas Lighting Ability
- Easy Installation
- Minimizes Inventory
- Replaces SIG1000



SIG102

### SIG100 Series Exact Replacement Hot Surface Igniters

- Replaces Exact OEM Hot Surface Igniters
- Highest density silicone carbide - greater physical strength
- Double helix spiral design - requires less current to light
- Easy installation - no modifications or adapters necessary

PART NO.	GEM
SIG100	IG100
SIG101	IG101
SIG102	IG102
SIG104	
SIG106	IG106
SIG107	IG107
SIG108	IG108
SIG109	IG109
SIG111	IG111

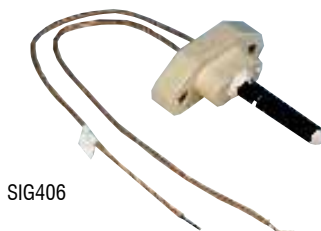

SIG406

### SIG400 Series Direct Replacement Hot Surface Igniters

- Strong design using more silicon carbide with deeper crystallization.
- Non-positional, double helix design - smoother ignition
- New slip fit kits, slide-in lock and go!

PART NO.	ROBERTSHAW
SIG401	41-401
SIG402	41-402
SIG403	41-403
SIG405	41-405
SIG406	41-406
SIG407	41-407
SIG408	41-408
SIG1100	41-409
SIG410	41-410
	41-411
SIG414	41-414

# Furnace Igniters

## OEM Cross Reference for Furnace Igniters

OEM NO.	DIRECT REPL.	FUNCT. REPL.	OEM NO.	DIRECT REPL.	FUNCT. REPL.	OEM NO.	DIRECT REPL.	FUNCT. REPL.	OEM NO.	DIRECT REPL.	FUNCT. REPL.	OEM NO.	DIRECT REPL.	FUNCT. REPL.
<b>American Road Equipment</b>			14740052		SIG1000	<b>John Woods Power</b>			<b>Perfection Schwank</b>			<b>Tappan (roof top system)</b>		
201W		SIG1000	14740511	SIG102	SIG1000	86483	GR412		108803-61	SIG406		632-320A		SIG1000
			14740521	SIG102	SIG1000	<b>L.B. White</b>			<b>Polaris</b>			<b>Trane / GE</b>		
<b>Amana</b>			<b>EZ-Flo</b>			120-07549	SIG100		6901800	SIG401		340039P01		SIG1000
10735002	SIG102	SIG414	62374	SIG107		<b>Lennox / Aire-Ease / American Air</b>			6903767	SIG401		B138196P01	SIG100	SIG1000
10041601		SIG414	<b>G.S.W.</b>			<b>Armstrong / Concord /</b>			6903768	SIG401		B1446676P01		SIG1000
767A-356		SIG414	71082	GR412		<b>Magic Chef</b>			<b>Raypak</b>			B1446676P02	SIG100	SIG1000
B1336101		SIG414	86483	GR412		33J3701		SIG1000	600915	SIG100		B340039P01		SIG1000
B1336102		SIG414	<b>Gem Products</b>			<b>Lochinvar</b>			<b>Rheem (Water Heater)</b>			IGN21	SIG100	SIG1000
B14010-15S		SIG414	SIG100	SIG100		PLT2400	SIG104	SIG1000	AP12553	GR412		IGN23		SIG1000
D99182		SIG414	SIG1000		SIG1000	PLT3400	SIG104		AP12554	GR412		IGN26		SIG1000
D9918201		SIG414	SIG101	SIG101	SIG1000	<b>Majestic</b>			75-07-061	GR412		IGN30		SIG1000
D9918202		SIG414	SIG102	SIG102	SIG1000	75-92-104	SIG402	SIG1000	<b>Rheem / Corsair / Ruud /</b>			IGN34		SIG1000
D9918202A		SIG414	SIG104	SIG104	SIG1000	75-92-105	SIG402	SIG1000	<b>Weather King</b>			KIT03033	SIG100	SIG1000
R0156525		SIG414	SIG106	SIG406		201N	SIG402	SIG1000	62-22441-01	SIG402	SIG1000	<b>Trianco / Heatmaster</b>		
R0157462		SIG414	SIG107	SIG107		201W	SIG402	SIG1000	62-22441-01	SIG408	SIG1000	2400-048	SIG401	
<b>American Appliance</b>			<b>Giant Water Heater (Power Vent)</b>			<b>Mor-Flo</b>			62-22441-01	SIG408	SIG1000	2400-286	SIG401	
6901800	SIG406		56000125		SIG1000	3200580	SIG402	SIG1000	62-22868-82		SIG1000	2600-359	SIG401	
6903767	SIG406		<b>Glow Core</b>			3200618	SIG402	SIG1000	62-22868-92		SIG1000	3079-100	SIG401	
271B	SIG406		1950001	SIG406		3210401	SIG406		62-22868-93	SIG408		933-102	SIG401	
<b>American Water Heater</b>			1950006	SIG104	SIG1000	<b>Nordyne / Frigidaire / Tappan /</b>			SP10972	SIG108	SIG1000	<b>Viessman</b>		
6901800	SIG401		HSRK7	SIG406		<b>Philco / Intertherm / Miller</b>			<b>Roberts Gordon</b>			9302-083	SIG100	
6903767	SIG401		<b>Goodman / Janitrol</b>			902661	SIG101	SIG1000	90434300		SIG1000	9302-094	SIG100	
6903768	SIG401		10735002	SIG102	SIG414	902694	SIG101	SIG1000	90436600	SIG402	SIG1000	<b>Wayne Home Equipment</b>		
<b>Armstrong Air</b>			10041601		SIG414	9031100	SIG104	SIG1000	<b>Robertshaw / Eaton / Invensys</b>			62821-001	SIG100	
38322B001		SIG1000	767A-356		SIG414	105141000		SIG1000	41-238		SIG1000	62821-002	SIG100	
<b>Brant Radiant</b>			B1336101		SIG414	632-0770		SIG1000	41-242		SIG1000	<b>Weil Mclain</b>		
201D		SIG1000	B1336102		SIG414	632-0880		SIG1000	41-401	SIG401		511-330-139	SIG100	
<b>Carrier / Payne / Day &amp; Night /</b>			B14010-15S	SIG414		RH62286892	SIG102	SIG1000	41-402	SIG402	SIG1000	511-330-188	SIG406	
<b>Bryant / BDP</b>			B1401009		SIG107	RH62286893	SIG102	SIG1000	41-403	SIG403	SIG1000	511-330-190	SIG100	
LH33ZS001A	SIG100		D99182		SIG414	<b>Norton</b>			41-405	SIG405	SIG1000	511-330-193	SIG100	
LH33ZS002	SIG100		D9918201		SIG414	101M	SIG409	SIG1000	41-406	SIG406		<b>White-Rogers</b>		
LH33ZS003	SIG100		D9918202		SIG414	101W		SIG1000	41-407	SIG407	SIG1000	767A-301	SIG100	
LH33ZS004	SIG100		D9918202A		SIG414	201	SIG403	SIG1000	41-408	SIG408	SIG1000	767A-303	SIG100	
<b>Claire Bros</b>			R0156525		SIG414	201A	SIG401		41-409	SIG409	SIG1000	767A-306	SIG100	
C-238	SIG102	SIG1000	R0157462		SIG414	201D	SIG405	SIG1000	41-410	SIG410	SIG1000	767A-309		SIG1000
C-238-1	SIG102	SIG1000	<b>Grimsby Stove</b>			201E	SIG406		41-412	SIG107		767A-310		SIG1000
C-242		SIG1000	ZCO-035	SIG102	SIG1000	201J	SIG406		<b>Snyder General</b>			767A-311		SIG1000
C-263		SIG1000	<b>H.B. Smith</b>			201K	SIG402	SIG1000	1380654	SIG100		767A-350	SIG100	
<b>Coleman</b>			50018	SIG100		201L	SIG402	SIG1000	1380672	SIG100		767A-353	SIG100	
1474-051		SIG1000	<b>Hupp Industries</b>			201M	SIG406		1380680	SIG100		767A-354	SIG100	
1474-052		SIG1000	09050		SIG1000	201N	SIG402	SIG1000	<b>Suburban</b>			767A-356		SIG1000
1474-511	SIG102	SIG1000	<b>ICP (International Comfort Products)</b>			201P		SIG1000	10098002	SIG402	SIG1000	767A-357	SIG100	
1474-521	SIG102	SIG1000	1096047	SIG107		201R		SIG1000	<b>Superior Fireplace</b>			767A-361	SIG100	
<b>Comfort Zone</b>			<b>Integra</b>			201S		SIG1000	94851		SIG1000	767A-364		SIG1000
150114-04-01		SIG1000	3260618	SIG402	SIG1000	201T	SIG402	SIG1000	<b>Surface Igniter / Carborundum</b>			767A-365		SIG1000
<b>Detroit</b>			6905032	SIG402	SIG1000	201U	SIG402	SIG1000	FC007	SIG101	SIG1000	767A-366		SIG1000
201D		SIG1000	<b>Intercity/Arco/Comfortmaker/</b>			201V		SIG1000	FC035	SIG101	SIG1000	<b>Williamson</b>		
<b>DMO Industries</b>			<b>Heil/Heil-Quaker/</b>			201W		SIG1000	FC035 KI	SIG101	SIG1000	9050	SIG102	SIG1000
20834	SIG102	SIG1000	<b>ICP Commercial/Tempstar</b>			201X		SIG1000	FC046	SIG102	SIG1000	<b>York / Borg Warner /</b>		
26789	SIG102	SIG1000	1001344	SIG405	SIG1000	201Y		SIG1000	FC046 KI	SIG102	SIG1000	<b>Frazier-Johnson / Luxaire</b>		
<b>Dornback</b>			1009604	SIG107		501A	GR412		FC047 KI	SIG104	SIG1000	025-27766-000		SIG1000
271W		SIG1000	100-9980	SIG102	SIG1000	<b>Olsen Industries</b>			FC047	SIG104	SIG1000	025-27774-000SIG100		
<b>Ducane</b>			1096048		SIG414	20834	SIG102	SIG1000	FC050	SIG100	SIG1000	025-27776-000SIG100		
20015201	SIG100		1148245	SIG405	SIG1000	26789	SIG102	SIG1000	FC050 KI	SIG405	SIG1000	025-29043-000SIG100		
<b>Enerco Tech</b>			1096047	SIG107					FC053	SIG401		025-29050-000SIG100		
10399		SIG1000							FC053 KI	SIG401		025-32625-000SIG102	SIG1000	
<b>Evcon</b>									FT001	SIG100		025-32626-000SIG102	SIG1000	
14740051		SIG1000							FT001 KI	SIG100		373-05342-700SIG102	SIG1000	
									FY009	SIG406		025-32626-000SIG102	SIG1000	
									FY009 KI	SIG406		373-09154-700SIG102	SIG1000	
												473-12509-001SIG102	SIG1000	

# Furnace Igniters

## SIG1100 Cross Reference - Also Replaces SUPCO SIG1000

Amana Icp/Heil/ 10735002Arco Aire	Rheem Rudd 62-22868-93	Norton 101M	
Arco AireComfortmaker	62-22441-01	201D	
See ICP Tempstar	62-22868-82	201K	
ArmstrongKeeprite	Roberts-Gordon	201L	
38322B0011096048	90434300	201M	
Clare Bros.1009604	90436600	201P	
C238 1001344	Superior	201W	
C238-1 1380680	Fireplace	271D	
Coleman/Evcon	1148245	94851	271M
14740511Integra	Trane	271N	
147405126905032	3400339P01	271P	
Detroit/ 3260618	B340039P01	271R	
Brant Radiant	Johnstone	B12996P01	271RS
201D L37-699	B144676P01	271W	
DMO/OlsenL37-700	B144676P02	Robertshaw/ Uniline	
ECR Ind. L37-812	B138196P01	41-238	
26789 L37-814	IGN21	41-242	
20834 L37-815	IGN23	41-402	
DornbackL37-816	IGN26	41-403	
271W L.B. White Co	IGN28	41-404	
Ducane 120-07549	IGN30	41-405	
20015201Lennox	IGN34	41-407	
Enerco Tech.33J3701	Viessmann	41-408	
10399 Majestic	9302-093	41-409	
Giant PV.75-92-104	9302-094	Wayne Home	41-410
Water Heaters	75-92-105	41-1090	
526000125Metzger	Equipment	Surface Igniter	
526000025201N	62821-001	62821-002	FC007
Goodman/Janitrol	201W	FC024	
B1172606Mor-Flo	Weil McLain	FC035	
B11939393200618	29074	511-330-139	FC046
Grimsby Stove	Nordyne/Tappan	FC050	
ZCO-350Frigidaire/Philco	511-330-193	FC051	
John Woods/Intertherm/Miller	511-330-190	White-Rodgers	
GSW PV. 903110	Williamson	09050	767A-301
Water Heaters	105141000	767A-303	
86483RH622286893	York	767A-306	
H.B. Smith632-0770	025-32626-000	767A-310	
50018 632-0880	473-12509-001	767A-311	
Hupp Ind 902661	373-09154-700	767A-350	
9050 902694	025-27774-000		
903758025-29043-000	767A-353		
632-3811025-29050-000	767A-354		
632-3540025-27766-000	767A-357		
Raypak025-30277-000	767A-361		
600915025-32638-002	767A-364		
025-32625-000	767A-365		
025-31801-000	767A-366		
373-05342-700	767A-370		
767A-371			
767A-372			

## Electrical Specifications for Round Igniters

PART NO.	SIC SERIES	STEADY STATE CURRENT	OHMS
SIG1100, SIG101, SIG102, SIG104, SIG106, IG107, SSIG108, SIG111, SIG112, SIG402, SIG403, SIG405, SIG406, SIG407, SIG408, SIG410, SIG414	FC	2.75 amps minimum @ 98 VAC 3.0-3.36 amps @ 115 VAC 4 amps maximum @ 132 VAC	36 @ 98 VAC 38-34 @ 115 VAC 33 @ 132 VAC
SIG100	FT	2.3 amps minimum @ 98 VAC 2.5-3.0 amps @ 115 VAC 3.3 amps maximum @ 132 VAC	43 @ 98 VAC 46-38 @ 115 VAC 40 @ 132 VAC
SIG113	FF	2.3 amps minimum @ 98 VAC 3.0-3.6 amps @ 115 vac 4 amps maximum @ 132 vac	43 @ 98 VAC 38-34 @ 115 VAC 33 @ 132 VAC

# Wall Thermostats



A Division of SUPCO

## Thermostats...loaded with features, designed for value!

### All CTC Thermostats Feature

User Friendly Programs and Features

- **Attractive Styling**  
Blends well in any residential application.
- **Overheat Protection**  
Prevents lock-up in the heat mode by not allowing heat to come on if temperature is over 95 degrees.
- **Static Protection**  
Handles electrical spikes of up to 20,000 volts that could otherwise damage the system.

See Selection Guide  
On Page 54

## All CTC Digital and Programmable Thermostats

### Features:

- Latching relays for system compatibility
- Soft touch keypad
- Low battery indicator
- INDIGLO® Backlight
- Easy, front load battery access
- 2 AA batteries included
- °F/°C selector
- 3 year warranty

### Are Compatible With:

- 24 VAC heat/cool, heat only or cool only systems
  - Gas, electric or oil systems
  - Millivolt systems
  - 2 wire hydronic systems
- (Not for use with 110/220V systems)**

### Have These Specifications:

- 20-30 VAC, 50/60 Hz
- Current draws 0.1 to 1.5 amps
- Temperature set range: 45°F to 95°F (7°C to 35°C)
- Operating differential +/- 1° F
- Compressor protection: 4 min. delay on break

## Touchscreen



### 43855

#### Universal Touchscreen Programmable Conventional Thermostat 3 Heat/2 Cool Thermostat/Multi-Stage Heat Pump with Optional Humidity Control



### Additional Features:

- Pre-programmed with easy to change presets
- Simultaneous Time and Temperature visibility for easy programming
- Large, easy to read display for clear, wide angle viewing
- Auto season changeover, ambi touch display glows red in heat mode and blue in cool mode.
- Humidity sensing control
- Refresh programmable fan
- Keyboard lock

- Filter Monitor
- Energy Monitor
- "System On" indicators
- Auto heat recovery
- Patented "Home Today" override
- Temporary and Vacation Hold override with Programmable Hold
- AC or battery powered. 3 AA batteries included
- Low battery warning

### Also Compatible With Most:

- Up to three-stage heat/two-stage cool conventional
  - Single-stage heat pumps
  - AC or hardwired
- (Not for use with 110/220V systems)*

### Additional Specifications:

- Current draws 2.0 Amps max per terminal. 4.0 Amps max overall.
- Temperature display limits: 15°F to 99°F (-9°C to 37°C)
- Terminations: RH, RC/R, C, Y1, Y2, W1, W2, W3, E, O, B, G, L, H
- Product dimensions: 6"W x 4 5/8"H x 1 3/8"D

## Digital



### 43054

#### For Conventional Systems and Single-Stage Heat Pumps with Blue Back Light

### Additional Features:

- Electronic digital accuracy
- Large, easy-to-read LCD
- Filter change indicator
- No programming required
- No leveling required

### Additional Specifications:

- 43054 Terminations: RC/O, RH/B, Y, W, G, R
- Bimetal freeze protection

### 43055

#### Has the same specifications as 43054, and includes a convenient Remote Control.

- Remote wireless up to 100 feet away





A Division of SUPCO

# Wall Thermostats



## 43057 ● Digital Heat Pump Thermostat



- Additional Features:**
- Filter monitor
  - AC powered with non-volatile memory to maintain user settings-no batteries required
  - Refresh programmable fan mode
  - Residential cooling fan delay, user selectable
  - Adjustable 1st and 2nd stage span adjustment
  - Staging timer
  - Heat/Cool auto cutoff
  - Bi-metal freeze protection

- Also Compatible With Most:**
- Two-stage heat pumps with 2 heat/2 cool, gas or electric auxiliary heat conventional
  - Two-stage heat pumps with 2 heat/1 cool, gas or electric auxiliary heat conventional
  - Single-stage heat pumps
  - Not for use with 110V/220V systems

- Additional Specifications:**
- Terminals: R, B, W2, E, G, O, Y2, Y1, L, C
  - Electrical Rating: 20-30 VAC, 50/60 Hz
  - Current Draw: 1 Amp max load/terminal, 2.5 Amp max load all
  - Compressor protection 3.5 min. delay on break
  - Product Dimensions: 4 7/8"W x 4 3/8"H x 1 3/8"D



43058

## 43058 ● For Multi-Stage Heat Pump/ Conventional Two-Stage Heat/ Cool Thermostat With Auto Season Changeover

- Additional Features:**
- Energy Monitor
  - Filter Monitor
  - No programming required
  - "System On" indicators
  - Keyboard lock
  - Auto heat recovery
  - AC powered with 2 AAA battery backup
  - Optional hardwire remote sensors (43658)

- Additional Specifications:**
- Display temperature limits: 40° to 95°F
  - Terminations: R, Y1, Y2, W1, W2, E, O, B, G, L, C
  - Remote Sensor Terminations: RS1+, RS1-, RS2+, RS2-
  - Conventional two-stage heat/cool systems (Not for use with 110V/220V systems)
  - Multi-stage heat/cool



43658

## 43658 ● Remote Sensor (Sold Separately)

- Also Compatible With Most:**
- Two-stage heat pumps with 2 heat/2 cool
  - Two-stage heat pumps with 2 heat/1 cool
  - Single-stage heat pumps

## Programmable



## 43154 ● 5 Day/2 Day Programming, 4 Periods Per Day For Conventional Heat/Cool or Single-Stage Heat Pump Systems

- Additional Features:**
- Adjustable cycle rate
  - Pre-programmed
  - Easy "Front Load" battery access
  - Mechanical low temperature protection
  - Filter Monitor
  - Up-opening door
  - Two-stage low battery warning with fail safe protection

- Also Compatible With Most:**
- Single-stage heat pumps
- Additional Specifications:**
- Terminations: G, RC, RH, Y/O, WB, Y1



## 43168 ● 5 Day/2 Day, 5-1-1 Day or 7 Day Programmable Multi Stage Heat Pump Thermostat

- Additional Features:**
- Blue back light
  - Filter Monitor
  - AC powered with non-volatile memory to maintain user settings-no batteries required
  - Refresh programmable fan mode
  - Residual cooling fan delay, user selectable
  - Adjustable 1st and 2nd stage span adjustment
  - Staging timer
  - Heat/Cool auto cutoff
  - Bi-metal freeze protection
  - Pre-Programmed
  - Easy "Front Load" battery case
  - Latching relay outputs



- Also Compatible With Most:**
- Two-stage heat pumps with 2 heat/2 cool, gas or electric auxiliary heat
  - Two-stage heat pumps with 2 heat/1 cool, gas or electric auxiliary heat
  - Single-stage heat pumps
  - Not for use with 110V/220V systems

- Additional Specifications:**
- Terminations: R, B, W2, E, G, O, Y2, Y1, L, C



# Wall Thermostats



A Division of SUPCO



**43355** ●  
7 Day Programming, 4 Programs Per Day



**Additional Features:**

- Adjustable cycle rate
- Pre-programmed
- Easy "Front Load" battery access
- Energy and filter use monitors
- Up-opening door
- Daylight Savings key
- Temporary and vacation overrides
- Programmable Hold
- Home Today Override
- Two-stage low battery warning with fail safe protection

**Also Compatible With Most:**

- Single-stage heat pumps

**Additional Specifications:**

- Terminations: G, RC, RH, Y/O, W/B, Y1



**43503** ●  
7 Day Programming, 4 Programs Per Day  
With Auto Season Changeover



**Additional Features:**

- Auto Programming
- Keyboard lock
- Easy Front Load battery access
- Energy and filter use monitors
- Patented Home Today temporary override
- Vacation Hold override

**Additional Specifications:**

- Terminations: RC, RH, W, Y/Y1, G, O/B



43558

**43558** ●  
7 Day Programming, 4 Programs  
Per Day For Multi-Stage Heat Pump/  
Conventional Two-Stage Heat/Cool With  
Auto-Season Changeover



**Additional Features:**

- Energy Monitor
- "System On" indicators
- Keyboard lock
- Auto heat recovery
- Preprogrammed
- Filter Monitor
- Temporary/Vacation overrides
- Programmable Hold
- Home Today override
- Auto season changeover
- Optional hardwire remote sensors (43658)
- AC powered with 2 AAA battery backup

**Also Compatible With Most:**

- Two-stage heat pumps with 2 heat/2 cool
- Two-stage heat pumps with 2 heat/1 cool
- Single-stage heat pumps
- Conventional two-stage heat/cool systems (Not for use with 110V/220V systems)
- Multi-stage heat/cool

**Additional Specifications:**

- Terminations: R, Y1, Y2, W1, W2, E, O, B, G, L, C



43658

**43658 Remote Sensor** (Sold Separately)



43665

**43665** ●  
7 Day Programming,  
4 Programs Per Day &  
Optional Remote Sensing



**Additional Features:**

- Pre-programmed with easy-to-change presets
- Programmable fan
- Keyboard lock
- Energy and filter use monitors
- Patented Home Today™ temporary override
- Temporary and vacation hold override with programmable hold
- Daylight saving key
- Tri-lingual English, Spanish, French display
- Mechanical low temperature protection

**Also Compatible With Most:**

- Single-stage heat pumps

**Additional Specifications:**

- Terminations: G, W/B, Y/O, R/C, RC1, RH, Y1
- Remote Sensor Terminations: Wireless
- Product Dimensions: 6 1/8"W x 5 1/8"H x 1 1/2"D



**43758**  
Wireless Remote Sensor  
(optional)





A Division of SUPCO

# Wall Thermostats

## Mechanical

All models offer our “quiet switching” mercury bulb design and require no additional sub-base for heating, cooling or heating/cooling installation. All deliver maximum performance at a value price! All Mechanical Thermostats have a one year warranty.



43004 – Horizontal



43005 – Vertical

### Heating/Cooling Thermostats

#### 43004 – Horizontal ●

- For use with most 4 or 5 wire 24 VAC systems and single-stage heat pumps
- Adjustable heat anticipator
- Terminations: RC, RH, W, Y, G, O, B

#### 43005 – Vertical



43320 – Vertical

### Cooling Only Thermostat

#### 43320 – Vertical ●

- For use with most 2 wire 24 VAC systems
- Fixed cooling anticipator
- Terminations: RC, Y



43309 – Horizontal



43359 – Horizontal

### Heating Only Thermostats

#### 43309 – Horizontal ●

- For use with most 2 wire 24 VAC and millivolt systems
- Adjustable heat anticipator
- Terminations: RH, W

#### 43359 – Horizontal

- 3 wire heat zone control
- Adjustable heat anticipator
- Terminations: R, Y, W

# Wall Thermostat Features



A Division of SUPCO

Mechanical		Adjustable Heat Anticipator	Quiet Switching	Most Gas, Oil or Electric	24 VAC Nominal	Millivolt	Terminals
43320	Vertical Cool Only		●		●		RC, Y
43309	Horizontal Heat Only	●	●	●	●	●	RH, W
43359	Horizontal Heat Zone Control		●	●	●	●	R, Y, W
43004	Horizontal Heat Cool	●	●	●	●		RH, RC, G,
43005	Vertical Heat Cool	●	●	●	●		RH, RC, G,

Y, W, O, B

Y, W, O, B

Digital		Large LCD Digital Accuracy	Easy to Read Display	Filter Change Indicator	Low °F/°C Readout	No Battery Powered	Heat/Cool & Battery Indicator	Leveling Required	Heat Only Systems	Terminals	Remote Sensor Terminals
43054	Electronic w/Blue Night-Light	●	●	●	●	●	●	●	●	RC/O, RH/B, Y, W, G, R	
43055	Electronic w/Blue Night-Light w/Remote	●	●	●	●	●	●	●	●	RC/O, RH/B, Y, W, G, R	
43057	Digital Multi-Stage Heat Pump/Conventional	●	●	●	●		●	●	●	R, B, W2, E, G, O, Y2, Y1, L, C	RS1+ RS1- RS2+ RS2-
43058	Digital Multi-Stage	●	●	●	●	Battery Backup	●	●	●	R, Y1, Y2, W1, W2,	RS1+ RS1-

Programmable		Program Flexibility	Programs Per Day	Pre Programmed	Auto Recovery	Filter Change Indicator	°F/°C Readout	Temporary & Vacation Overrides	Home Today Override	Energy Monitor	Battery Powered	Auto Changeover	Keyboard Lock	Single-Stage Heat Heat Pump	Terminals	Remote Sensor Terminals
43154	Programmable w/Blue Night-Light	5+2	4	●	●	●	●	●		●	●			●	RC, RH, Y/O, W/B, Y1, G	
43168	Programmable Multi-Stage Heat Pump	5+2 5+1+1 7	4	●	●	●	●	●	●	●			●	●	R, B, W2, W, G, O, Y2, Y1, L, C	
43355	Programmable w/Blue Night-Light	7	4	●	●	●	●	●	●	●	●			●	RC, RH, Y/O, W/B, Y1, G	
43503	Programmable w/AutoSeason Changeover	7	4	●	●	●	●	●	●	●	●	●	●	●	W, RH, RC, G, Y/Y1, O/B	
43558	Programmable Multi-Stage Heat Pump/Conventional	7	4	●	●	●	●	●	●	●	Battery Backup	●	●	●	R, Y1, Y2, W1, W2, E, O, B, G, L, C	RS1+ RS1- RS2+ RS2-
43665	Programmable w/AutoSeason Changeover			●	●	●	●	●	●	●	●	●	●	●	G, W/B, Y/O, RC, RCI, RH, Y1	WIRELESS
43855	Touchscreen Programmable 3H/2C Conventional Heat Pump			●	●	●	●	●	●	●	●	●	●	●	RH, RC/R, C, Y1, Y2, W1, W2, W3, E, O, B, G, L, H	

# Thermostats Guards

SUPCO offers a complete line of metal and plastic thermostat guards for the HVAC industry. Manufactured with the highest quality materials and production standards to ensure rugged dependability and attractive appearance.

## Metal Thermostat Guards

- 18-22 Gauge Steel
- Baked Enamel Finish
- Louvered Cover
- Maximum Protection

## Plastic Thermostat Guards

- Hi-Impact Plastic
- Clear
- Opaque
- Bronze

## All Models

- Locking Key
- Mounting hardware
- Vertical or Horizontal Mounting



Designer Series  
BTG-DK



Universal Series  
BTG-U02

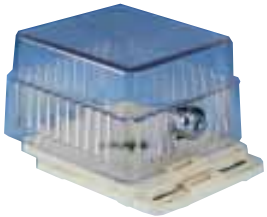

Elite Series  
BTG-EK



Classic Series  
BTG-O



Regal Series  
BTG-RK



Sentinal Series  
BTG-54VL

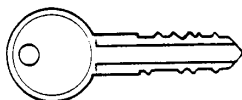

F336

PART NO.	DESCRIPTION	INSIDE DIMENSIONS	
		SOLID BASE (H x W x D)	RING BASE (H x W x D)
<b>Designer</b>			
BTG-DK	Clear Plastic	4 1/4" x 7 5/8" x 2 1/8"	4 1/8" x 7-1/16" x 2-1/4"
BTG-DB2	Bronze Plastic	4 1/4" x 7 5/8" x 2 1/8"	4 1/8" x 7-1/16" x 2-1/4"
BTG-DO	Opaque Plastic	4 1/4" x 7 5/8" x 2 1/8"	4 1/8" x 7-1/16" x 2-1/4"
<b>Universal</b>			
BTG-UK2	Clear Plastic	8 1/4" x 5 3/8" x 3 1/2"	8 1/8" x 4 5/8" x 3-5/8"
BTG-UB2	Bronze Plastic	8 1/4" x 5 3/8" x 3 1/2"	8 1/8" x 4 5/8" x 3-5/8"
BTG-U02	Opaque Plastic	8 1/4" x 5 3/8" x 3 1/2"	8 1/8" x 4 5/8" x 3-5/8"
BTG-UM	Metal	8 1/4" x 5 3/8" x 3 1/2"	-
BTG-UWM	Metal	-	6 3/4" x 4 1/2" x 3 9/16"
<b>Elite</b>			
BTG-EK	Clear Plastic	3 7/8" x 3 1/2" x 2 1/2"	-
BTG-EO	Opaque Plastic	3 7/8" x 3 1/2" x 2 1/2"	-
BTG-EM	Metal	3 7/8" x 3 1/2" x 2 1/2"	-
<b>Classic</b>			
BTG-K	Clear Plastic	5 1/4" x 4 3/8" x 3"	5 1/4" x 4 5/8" x 3 1/4"
BTG-O	Opaque Plastic	5 1/4" x 4 3/8" x 3"	5 1/4" x 4 5/8" x 3 1/4"
BTG-KM	Metal	5 1/4" x 4 3/8" x 3"	-
BTG-KWM	Metal	-	5 1/4" x 4 5/8" x 3 1/4"
<b>Regal</b>			
BTG-RK	Clear Plastic	6 3/8" x 3 1/2" x 3"	6 3/8" x 3 1/2" x 3 1/4"
BTG-RB2	Bronze Plastic	6 3/8" x 3 1/2" x 3"	6 3/8" x 3 1/2" x 3 1/4"
BTG-RO	Opaque Plastic	6 3/8" x 3 1/2" x 3"	6 3/8" x 3 1/2" x 3 1/4"
BTG-RM	Metal	6 3/8" x 3 1/2" x 3"	-
BTG-RWM	Metal	-	6 3/8" x 3 1/2" x 3 1/4"
<b>Sentinal</b>			
BTG-54VL	Metal Hinged	6 1/4" x 4 1/4" x 3 1/8"	-
BTG-54VLW	Metal Hinged	-	6" x 3 3/4" x 3 1/8"
F336	Replacement Key	Fits All Models	

# Service & Installation Products

## Li'L Popper Control Board Circuit Breaker

The POP3 or POP5 provide a temporary emergency fix for control boards that continue to blow fuses or that are shorted out.



### Features/Benefits

- Two common sizes to choose from: 3 or 5 amp
- Includes quick setting thermal cut out.
- Self-adhesive backing for easy temporary installation
- Keeps homeowner and or building owner up and running with no inconvenient down time until the original control board can be replaced.

### Applications

- Gas Fired Equipment
- Furnaces
- Roof Top Units
- Boilers
- Unit Heaters
- Water Heaters
- Pool Heaters
- Hot Tubs
- Fireplaces

### Product Information

PART NO.	Voltage	DESCRIPTION
POP3	24	3 amp control board circuit breaker
POP5	120/240	5 amp control board circuit breaker

### Tech Tip

- SUPCO recommends using the Li'L Popper as a **"temporary fix"** only, until the original control board can be replaced.

## ECAP321 High Efficiency PVC Flue Cap

The affordable approach to flue pipe problems starts at the TOP! The ECAP321 PVC Flue Cap protects today's high efficiency furnaces from dirt, moisture and other debris.



### Features/Benefits

- Protection for high efficiency furnaces
- Universal flue cap fits 1.5", 2" and 3" PVC pipe
- Reduces draft inducer motor rust
- Helps to eliminate pressure switch service calls
- Resistant to UV radiation and oxidative degradation
- CSA approved for use in 90% AFUE heating applications

### Applications

- 90% high efficiency furnaces with a PVC flue pipe
- Used for vertical or horizontal venting applications



## Anti-Vibration Pads

SUPCO offers four different types of Anti Vibration Pads that provide vibration dampening and leveling of HVAC/R, Appliance and Industrial equipment.



ISO Cube

### Features/Benefits

- Three different types include Rubber & Cork, All Rubber and ISO Cube.
- Made of the highest quality elastomeric materials.
- Oil, chemical & age resistant padding.
- Maximum load capacity
  - 50 psi for Rubber & Cork and All Rubber.
  - 180 psi for the ISO Cube.



### Applications

- Air Conditioners
- Heat Pumps
- Furnaces
- Boilers
- Air Handlers
- Compressors
- Ice Machines
- Refrigerators
- Washers
- Dryers
- Dishwashers
- Stoves & Ovens
- Presses
- Machinery
- Shelving



All Rubber

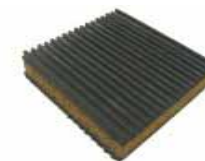

Rubber & Cork

### General Description

PART NO.	DESCRIPTION	CARTON QTY.
SP2C	2" x 2" x 7/8" Rubber/Cork Pad	48
SP3C	3" x 3" x 7/8" Rubber/Cork Pad	36
SP4C	4" x 4" x 7/8" Rubber/Cork Pad	24
SP6C	6" x 6" x 7/8" Rubber/Cork Pad	24
SP12C	12" x 12" x 7/8" Rubber/Cork Pad	12
SP18C	18" x 18" x 7/8" Rubber/Cork Pad	6
<b>ALL RUBBER ANTI VIBRATION PADad</b>		
SP2	2" x 2" x 3/8" All Rubber Pad	48
SP3	3" x 3" x 3/8" All Rubber Pad	36
SP4	4" x 4" x 3/8" All Rubber Pad	24
SP6	6" x 6" x 3/8" All Rubber Pad	24
SP18	18" x 18" x 3/8" All Rubber Pad	6
<b>ISO CUBE ANTI VIBRATION PAD</b>		
SIS018	18" x 18" x 3/4" ISO Cube	6

### Specifications

- Pull Strength: 6.5 Mpa
- Extension Rate Until Broken: 310%
- Permanent Distortion Rate Until Broken: 12%

# The Hard Start Pioneer...

## Your Source For All Hard Starts

With the constant changes in compressor technologies, hard start development has evolved from simple Positive Temperature Coefficient (PTC) Technology through 2 and 3 wire Potential Relay Technology. Trust **SUPCO-the Hard Start-Pioneer**-to provide the choice that fits your application.



### SPP Series

The first 2-wire Hard Start utilizing PTC Technology, still provides field proven reliability.

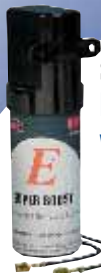

SPPE "E Class" Series

Economical Potential Relay Technology, with the comfort of a backup safety.



### SK3W Series

3-Wire Potential Relay Technology, for the closest OEM equivalent, with easy installation.

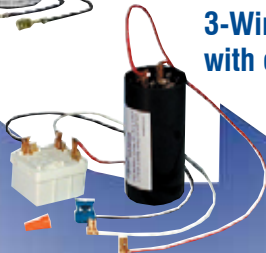

High Torque Series

SUPCO's Ultimate Hard Start, combining unequalled current handling ability and high energy capacity.



40 Amp electronic potential relay (EPR) provides superior performance for low voltage applications.

See Pages 2-3 for more details

### URCO Ultimate Series

Newly Designed for Systems with or without Run Capacitors, the URCO Series provides the **ULTIMATE** in protection for all SUPCO's Ultimate Hard Start, combining unequalled current handling ability and high energy capacity.



- Pre-wired to work in systems with or without a run capacitor
- Provides High Torque Start
- Reduces Truck Stock - This is the only one you need!
- 1/4" push-on terminals for run capacitor
- 90° Fusite connector for compressor
- Including wiring diagram
- Includes wire nuts

See Page 59 for more details

# Refrigeration Relays, Overloads & Hard Starts

## For Refrigeration Systems Without Run Capacitors

SUPCO offers the most complete line of refrigeration relays, overloads and hard starts in the industry. For refrigeration systems with and without run capacitors, just choose the right combination for your application. All combinations are pre-wired for fast installation.



### ICG and PO Series Relays

#### Features/Benefits

- ICG Series features a “snap-on” bracket
- PO Series installs on compressors with “pin-type” terminals.
- Fastest cool down time of any solid state relays
- Can be used with and without start capacitor.

#### Applications

- One size for all compressors from 1/12 hp through 1/2 hp.
- Replaces all current type relays.

### Selection Table For Refrigeration Systems Without Run Capacitors

PART NO.	RELAY OVERLOAD		START CAPACITOR	MOUNTING	hp RATING	VOLTAGE (VAC)
	RELAY	OVERLOAD	CAPACITOR	MOUNTING	hp RATING	VOLTAGE (VAC)
ICG1	*			Quick Connect	1/12 - 1/2	115
ICG-220	*			Quick Connect	1/12 - 1/2	230
PO115	*			Push - on	1/12 - 1/2	115
PO230	*			Push - on	1/12 - 1/2	230
R081	*	*		Quick Connect	1/12 - 1/5	115
R041	*	*		Quick Connect	1/4 - 1/3	115
R082	*	*		Quick Connect	1/12 - 1/8	230
R062	*	*		Quick Connect	1/6 - 1/5	230
R042	*	*		Quick Connect	1/4 - 1/3	230
PRO81	*	*		Push - on	1/12 - 1/5	115
PRO41	*	*		Push - on	1/4 - 1/3	115
PRO21	*	*		Push - on	1/2	115
PRO82	*	*		Push - on	1/12 - 1/8	230
PRO62	*	*		Push - on	1/6 - 1/5	230
PRO42	*	*		Push - on	1/4 - 1/3	230
PRO22	*	*		Push - on	1/2 - 2/3	230
RSC20	*		*	Quick Connect	1/12 - 1/2	230
RC0810	*	*	*	Quick Connect	1/12 - 1/5	115
RC0410	*	*	*	Quick Connect	1/4 - 1/3	115
RC0210	*	*	*	Quick Connect	1/2	115
RC0820	*	*	*	Quick Connect	1/12 - 1/8	230
RC0620	*	*	*	Quick Connect	1/6 - 1/5	230
RC0420	*	*	*	Quick Connect	1/4 - 1/3	230
RC0220	*	*	*	Quick Connect	1/2	230
SS410	*	*	*	Quick Connect	1/4 - 1/3	115



### RO & PRO Series Relay and Overload Combinations

- RO Series features “snap-on” bracket
- PRO Series installs on “pin-type” terminal.
- Locked rotor protection eliminates start winding overheating
- Can be used with and without start capacitor motors from 1/4 to 1/3 hp.

#### Applications

- Select the right match to replace refrigerator compressor relay and overload units from 1/12 through 1/2 hp, 115 – 230 VAC.



### RSC Series Relay and Start Capacitor Combination

- Select the right match to replace refrigerator compressor relay and overload units from 1/12 through 1/2 hp, 115 – 230 VAC.



### RCO Series 3 N' 1 Relay, Overload and Start Capacitor Combination

- Replaces current-type relays
  - Provides a boost for hard start and unbalanced systems
  - Prevents low voltage starting problems
- Applications**
- One size for all compressors from 1/12 hp through 1/2 hp.
  - For domestic and commercial refrigeration systems and freezers



### SS410 Super Start Relay Overload Combination

- Replaces relay, overload and provides a boost for hard start and unbalanced systems
- Prevents low voltage starting problems

### SS410 Super Start Relay Overload Combination

- Equipped with an electro-mechanical relay, locked rotor protector and a 255  $\mu$ F start capacitor.
- Increases torque to its maximum capacity

### RCO/URCO/PRO/URPO/RO/URO Current Ratings

PART NO.	FULL LOAD	TRIP IN
	AMPS	CURRENT AFTER 6-16 SEC.
RC0810/URCO810/PRO81/URPO81/R081/URO81	4.05Amps	12 Amps
RC0410/URCO410/PRO41/URPO41/R041/URO41	7.5 Amps	22 Amps
RC0210/URCO210	13.3 Amps	40 Amps
RC0820/URCO82/PRO82/URP082/R082/URO82	1.66 Amps	6 Amps
RC0420/URCO42/PRO42/URP042/R042/URO42	4.05 Amps	12 Amps
RC0620/URCO62/PRO62/URP062/R062/URO62	1.66 Amps	6 Amps
RC0220/PRO22/UPRO22/URO22	7.5 Amps	22 Amps

#### Applications

- Select the right match to replace refrigerator compressor relay and overload units from 1/12 through 1/2 hp, 115 – 230 VAC.
- For all capillary systems

#### Applications

- For all motors including high starting torque motors from 1/4 to 1/3 hp.

#### Features/Benefits

# Refrigeration Relays, Overloads & Hard Starts

For Refrigeration Systems **WITH OR WITHOUT RUN** Capacitors Maintain a high efficiency system or save an old system with SUPCO's Ultimate Series.



## URCO Series Ultimate Relay Capacitor Overload

### Features/Benefits

- Replaces relay, capacitor and overload
- Available in popular sizes, ranging from 1/12 hp to 1/2 hp
  - "Push-on" compressor terminals, and 1/4" capacitor terminals
- Designed for modern high efficiency compressors
- Helps older compressors to start and run cooler
- Easy mount clip for quick installation
- Easy to read instructions
- Prevents low voltage starting problems

### Applications

- Domestic Refrigerator Compressors to 1/2 hp
- Light Commercial Refrigeration Compressors to 1/2 hp.

- Works on "RSIR", "CSIR", "PSC", & "CSR" compressors

**3 N' 1 for High torque starts**  
Run Capacitor Wiring for high efficiency systems

PART NO.	hp RATING	VOLTS
URCO210	1/3 to 1/2	115
URCO410	1/4 to 1/3	115
URCO810	1/12 to 1/5	115



## URCORC Series 4 N' 1 Ultimate Relay, Capacitor, Overload and Run Capacitor

### Features/Benefits

- Same Features and Benefits of the Ultimate URCO Series
- Adds a closely matches system Run Capacitor

Replaces current-type relays

PART NO.	hp RATING	RUN CAPACITOR	
		Size $\mu$ Fd	VOLTS
URCO810RC	1/12 to 1/5	12.5	115
URCO410RC	1/4 to 1/3	15	115
URCO210RC	1/3 to 1/2	20	115



## URO Ultimate Relay Overload

### Features/Benefits

- Replaces relay and overload
- Locked rotor protection, eliminates start winding overheating
- Available in popular sizes, ranging from 1/12 hp to 1/2 hp
- "Snap -on" bracket for easy mounting
- Quick and easy installation
- Wiring instructions on the package
- Instructions on adding a start capacitor and/or run capacitor
- Wire leads for those odd installations, Wire nuts included

### Applications

- Domestic Refrigerator Compressors to 1/2 hp
- Light Commercial Refrigeration Compressors to 1/2 hp.

- Works on "RSIR", "CSIR", "PSC", & "CSR" compressors

Replaces relay & overload

PART NO.	hp RATING	VOLTS
URO41	1/4 to 1/3	115
URO81	1/12 to 1/5	115



## UPRO Ultimate Push-on Relay

### Features/Benefits

- Replaces relay and overload
- Available in popular sizes, ranging from 1/12 hp to 1/2 hp
- "Push-on" relay overload
- Quick connect push-on terminals for run and/or start capacitor
- Wiring instructions on the package
- Instructions for adding a start capacitor and/or run capacitor

### Applications

- Domestic Refrigerator Compressors to 1/2 hp
- Light Commercial Refrigeration Compressors to 1/2 hp.

- Works on "RSIR", "CSIR", "PSC", & "CSR" compressors

Replaces relay & overload

PART NO.	hp RATING	VOLTS
UPRO21	1/3 to 1/2	115
UPRO41	1/4 to 1/3	115
UPRO81	1/12 to 1/5	115



## URSC10/URSC20 Ultimate Relay Start Capacitor

### Features/Benefits

- Replaces current-type relays
- Provides a boost for hard start and unbalanced systems
- No additional wires required

### Applications

- One size for all compressors from 1/20 hp to 1/2 hp
- For domestic and commercial refrigeration systems and freezers
- Works on "RSIR", "CSIR", "PSC", & "CSR" compressors

Replaces current-type relays

PART NO.	hp RATING	VOLTS
URSC10	1/20 to 1/2	120
URSC20	1/20 to 1/2	240



# Refrigeration Relays, Overloads & Hard Starts

## OV Series Universal Replacement Motor Protectors

### Features/Benefits

- Built in temperature activated disc opens and closes the motor overload protector's contacts.
- Excessive heat generated by the compressor, motor or crankcase heater will open the contacts to help protect the equipment from serious damage or burnout.
- UL and CSA Approved

### Applications

- Used in heat pumps, air conditioners, motors, refrigerators, freezers, pumps, water coolers, and heating applications.



### OVKIT Overload Kit

- Contains one of each overload (10 total)

PART NO.	LOCKED ROTOR		HORSEPOWER AT 120 VOLTS										GEM NO.	MARS NO.		
	AMPS	AMPS	1/20	1/1	1/10	1/8	1/6	1/5	1/4	1/3	1/2	3/4				
OV32	12.0	13.5	•	•											MP359	35004
OV34	14.0	15.5		•	•	•	•	•							MP358	35007
OV36	16.0	18.0			•	•	•	•							MP357	35009
OV38	18.5	22.0			•	•	•	•	•						MP354	35010
OV40	22.5	26.5					•	•	•						MP360	35011
OV42	27.0	31.0						•	•	•					MP355	35012
OV44	31.5	35.5								•	•				MP361	35017
OV46	36.0	40.0									•	•			MP352	35018
OV48	40.5	44.5										•	•		MP351	35019
OV50	45.0	49.0											•		MP362	35020

PART NO.	LOCKED ROTOR		HORSEPOWER AT 120 VOLTS											GEM NO.	MARS NO.		
	AMPS	AMPS	1/10	1/8	1/6	1/5	1/4	1/4+	1/3	1/3+	1/2	1/2+	3/4			1	
OV32	12.0	13.5	•	•	•	•	•	•	•							MP359	35004
OV34	14.0	15.5	•	•	•	•	•	•	•							MP358	35007
OV36	16.0	18.0				•	•	•	•	•						MP357	35009
OV38	18.5	22.0				•	•	•	•	•	•					MP354	35010
OV40	22.5	26.5						•	•	•	•	•	•			MP360	35011
OV42	27.0	31.0							•	•	•	•	•	•		MP355	35012
OV44	31.5	35.5										•	•	•		MP361	35017
OV46	36.0	40.0											•	•		MP352	35018
OV48	40.5	44.5												•		MP351	35019
OV50	45.0	49.0													•	MP362	35020

This application guide is offered as a guide only when no other information is available.

The application will vary with compressor manufacturer's systems and condenser applications (static, fan, and water cooled, etc.)

Other factors include refrigerant, motor type, and efficiency.



### Application Note: Locked Rotor Amperage Measurement. To determine the locked rotor amperage use the following procedure:

1. Disconnect source of electrical supply.
2. By-pass defective overload with jumper.
3. Remove wire from start terminal of compressor.
4. Place hook-on ammeter on wire going to common or run terminal of compressor.
5. Connect plug to source of current and read ammeter.
6. If unit does not have a start capacitor, add 1/2 of ampere reading to obtain the locked rotor amps.  
Example: If ampere reading is 21, add 1/2 (+11.5) = 32.5 locked rotor amps.
7. If unit has a start capacitor, add 10% of ampere reading. Example: If ampere reading is 21, add 10% (+2.1) = 23.1 locked rotor amps.
8. Replace defective overload and replace wire removed from start terminal.

**NOTE:** The above procedure should only be used when the motor winding is at ambient temperature.

### Direct Replacement Solid State Relays, Overloads and Relay/Overload Combinations

- Direct Replacements for numerous OEM's
- Use OL Series Overloads with IC Series, PO Series and UR115



PART NO.	RELAY OVERLOAD	HORSEPOWER	VAC	# OF TERMINALS	COMPRESSOR CONNECTIONS	CAPATIBLE	CAPACITOR REPLACES OEM NO.
IC100	*	---	1/12 to 1/3	120	2	Yes	216594300, WR7X194, WR7X214, 4318083
IC102	*	---	1/2 to 1/3	120	3	Yes	5303007173, WR7X240, WR7X5142, 68857-1
OL1	---	*	1/5 to 1/4	120/240	1	---	5303299560, 216100110
OL2	---	*	1/4 to 1/3+	120/240	1	---	5303270406, WR8X122
OL3	---	*	1/6 to 1/5	120/240	1	---	5303276514
OL4	---	*	1/4 to 1/3+	120/240	1	---	5303206885, 2154945

\* IC100, IC102 replaces PON

# Refrigeration Relays, Overloads & Hard Starts

## Motor Protector Cross Reference

HP/TYPE	SUPCO OV	TECUMSEH O/L	HP/TYPE	SUPCO OV	TECUMSEH O/L	HP/TYPE	SUPCO OV	TECUMSEH O/L	HP/TYPE	SUPCO OV	TECUMSEH O/L		
1/8 Fan	<b>OV34</b>	83281 / 83282	1/5 Fan	<b>OV38</b>	83030 / 83131	1/4 Static	<b>OV44</b>	83013 / 83017	1/3 Fan	<b>OV46</b>	83031 / 83074		
		83316 / 83438			83183 / 83183-1			83036 / 83063			83168 / 83168-1		
		83441 / 83461			83290 / 83426			83145-1 / 83172			83257 / 83257-1		
		83473 / 83606			83439 / 83448			83172 / 83172-1			83257-2 / 83293		
		83628 / 83711			83743 / 83743-1			83192 / 83192 -1			83307 / 83332		
1/6 Fan	<b>OV36</b>	83018 / 83021	1/6 Static		83746 / 83746-1			83321 / 83373			83390 / 83413		
		83042 / 83077			83771			83376-1 / 83378			83413-1 / 83415		
		83091 / 83160			1/5 Static			<b>OV40</b>			83400 / 83435	83429 / 83430	
		83160-1 / 83165									8300MRT58	83453 / 83454	
		83165-1 / 83191									83047 / 83171	83464 / 83498	
		8191-1 / 83287						83171-1 / 83291			83681 / 83694	83498-1 / 83625	
		83463 / 83691						83366 / 83391			83736-1 / 83766	83631 / 83637	
83006		83392	83376-1 / 83378	83640 / 83708									
			83789	83713 / 83714 / 83754									
			1/4 Fan	<b>OV42</b>	83011 / 83139						1/3 Static	<b>OV48</b>	8300MRT26
					83161 / 83161-1								8300MRT60
					83163 / 83163-1								83219
					83259 / 83289								83434
					83292 / 83323								83673
													83765

## Valves & Fittings



### BPV Series Bullet® Piercing Valves

The *ONLY* valve with a permanent type, patented gasket application!



SUPCO's "Bullet® Piercing Valve" utilizes the same type of gasket found under the head plate of most air conditioning compressors. When installed, the gasket actually compresses the copper tubing .020" creating a permanent, leakproof seal that will withstand any pressure and temperature for the life of the unit.

#### Features

- Patented valve gasket application provides 50 times more sealing area than competitive "O" ring types
- A sealing force of over 180 inch lbs., torque tested with 500 lbs., pressure tested at 250°F
- Precision piercing needle is engineered for concentricity and hardness to insure perfect seating every time
- Nonpositional mounting — No adapter valve required
- Requires only a 2" clearance area for installation and operation
- Hex key wrench included — No additional tools required
- Corrosion resistant plated

#### Applications

- Install on the high side as a permanent valve on the job
- Install on round suction lines or uneven tubing

PART NO.	O.D. TUBING SIZE	PACKAGING
<b>BPV31*</b>	1/4", 5/16", 3/8"	12/Box
<b>BPV31D*</b>	1/4", 5/16", 3/8"	48/Box
<b>BPV21*</b>	1/2", 5/8"	8/Box
<b>BPV36</b>	3/16"	12/Box
<b>BPV14</b>	1/4"	12/Box
<b>BPV56</b>	5/16"	12/Box
<b>BPV38</b>	3/8"	12/Box
<b>BPV12</b>	1/2"	8/Box
<b>BPV58</b>	5/8"	8/Box
<b>BPV34</b>	3/4"	1/Box
<b>BPV78</b>	7/8"	1/Box

\*NOTE: BPV31 and BPV21 are furnished with adapter sleeves for indicated multiple use applications.

## Gasket "O" Rings



PART NO.	ID SIZE	DESCRIPTION	PART NO.	ID SIZE	DESCRIPTION
<b>SF0099</b>	5/32"	Used for SF5050 Valve	<b>SF1060</b>	3/16"	Used in brass caps.
<b>SF0101</b>	1/4"	—	<b>SF1090</b>	5/16"	Black rubber (used for SF2070)
<b>SF0111</b>	5/16"	Black rubber (used for SF3900)	<b>SF5501</b>	1/4"	White teflon (used for SF5500 Series)

# Valves & Fittings



## SA Series Adjustable Line Tap Valves

### Features

- Available in two sizes to accommodate five different OD tube sizes.
- Depressor valve action
- Can be mounted in any position
- Retracting needle ensures no restriction
- Throw away depressor pin simplifies line piercing
- Hex wrench included
- Adapter sleeves included
- Can be used with all refrigerants including R410A
- Maximum operating pressure 800 PSI
- Sold in 12 packs

### Applications

- Used to provide access fitting without having to remove refrigerant from air conditioning, refrigeration and heat pump systems.

PART NO.	TUBE SIZE OD	REPLACES
SA1	1/4", 5/16", 3/8"	A1 Watsco, A1 Diversitech, QTM1
SA2	1/2", 5/8"	A2 Watsco, A2 Diversitech, QTM2

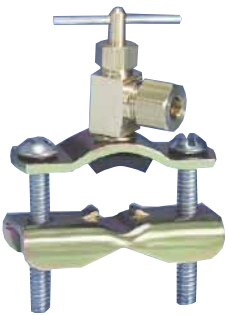

## STV Series Self-Tapping Water Valves

### Features

- Self piercing on copper tubing or 0.035" wall hard PVC
- Fits 3/8" O.D. through 1 3/8" O.D. tubing or pipe
- Can be installed on pipe with existing hole
- Stainless steel piercing needle
- Molded gasket has a two stage seal on both tubing and valve
- Threaded bottom bracket for easy installation
- Includes all fittings for copper and plastic tubing
- Maximum water temperature 180°F/82°C

PART NO.	FLOW RATE	OUTLET	PIERCING NEEDLE	APPLICATION	COMMENTS
STV2	1 GPM	1/4" Comp.	1/8" Dia. (Hollow)	Ice Maker Kits	Reversible lower bracket
STV3	1 GPM	1/4" Comp.	1/8" Dia. (Hollow)	Humidifier Kits	
STV4	1 GPM	1/4" Comp.	3/32" Dia. (Solid, retractable)	Humidifier Kits	1/8" M.P.T. on body valve included



## STV2D Conventional "Drill" Type Valve

### Features

- Must pre-drill 1/4" hole in pipe or tubing
- Increased water flow from standard water valve
- Fits up to 1 3/8" O.D. Copper tubing
- Fits 1/2" or 3/4" galvanized iron water pipe
- Flow rate: 1 GPM
- Maximum water temperature 180°F/82°C
- Includes all fittings for 1/4" O.D. copper and plastic tubing

**Tech Tip:** Designed to be used on city water pressure only 30-40 psi.



## FTV Series Self-Tapping Valves

TAP INTO ANY TUBE OR PIPE WITHOUT SHUTTING DOWN, DRILLING OR CUTTING!

### Applications

Humidifiers, water coolers, vending machines, oil lines and steam systems.

- Maximum operating pressure 500 psi

PART NO.	BRANCH TAP FITTING	APPLICATION
FTV12	3/8" SAE Flare	1/2" Steel or brass pipe approx. 7/8" O.D.

Not intended for gas applications.

## Line Service Valves



PART NO.	DESCRIPTION	PIPE THREAD	PART NO.	DESCRIPTION	PIPE THREAD
SF1010	1/8" copper tubing, wrench cap and core	—	SF3603	3/16" copper tubing, wrench cap and core	1/8" m.
SF2525	1/4" copper tubing, wrench cap and core	—	SF3604	1/4" copper tubing, wrench cap and core	1/8" m.
SF3600	1/8" ID hole, 3/16", 1/4", 5/16" steps, 1/8" MPT below hex wrench cap and core	—	SF3605	5/16" copper tubing, wrench cap and core	—
SF3602	1/4" copper tubing, 3/16" & 1/8" copper bushings, wrench cap and core	1/8" m.	SF3606	3/8" copper tubing, wrench cap and core	—
			SF3608	1/8" copper tubing, wrench cap and core	1/8" m.



## SF5421 Tee Fitting Service Valve

SF5421 is a copper tee with the body brazed on. Furnished complete with core and wrench cap. The 1/4" I.D. x 5/16" O.D. will service 1/4", 5/16", and 3/8" tubing.

# Valves & Fittings

## SF5000 Series Saddle Valve Copper to Copper



Completely self tapping. Steel pin with core penetrates line and is locked into valve body in one operation, simply by tightening cap.

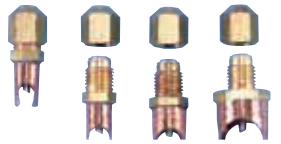

SF5514 SF5516 SF5538 SF5558



SF5518 SF5534 SF5578

PART NO.	TUBING	PART NO.	TUBING
SF5512	1/2" O.D.	SF5534	3/4" O.D.
SF5514	1/4" O.D.	SF5538	3/8" O.D.
SF5516	5/16" O.D.	SF5558	5/8" O.D.
SF5518	1 1/8" O.D.	SF5578	7/8" O.D.

## Replacement Gasket

PART NO.	DESCRIPTION
SF5501	25 per pack

## SF8400 Series Economy Service Valves

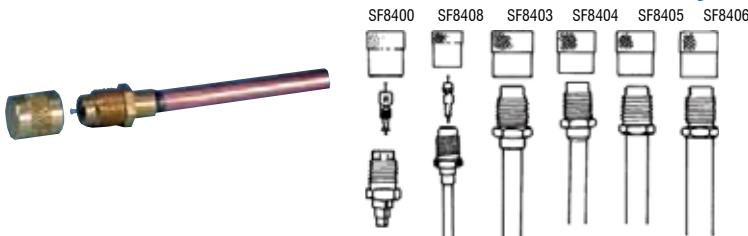

PART NO.	TUBING	DESCRIPTION
SF8400	1/8"	3/16", 1/4", 5/16" Step
SF8408	1/8" Tube	3/16", 1/4", 5/16" Step
SF8403	3/16" Tube	1/4" Step
SF8404	1/4" Tube	
SF8405	5/16" Tube	
SF8406	3/8" Tube	

Braze Only with SF4450 Core

## SF8000 Series Universal Line Valves

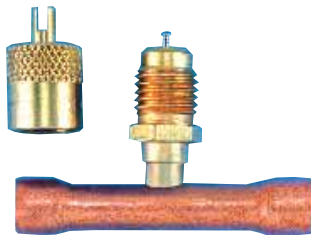

Available in various sizes. Copper Tee with the body brazed on. Two styles - a flared or straight end copper piece. (See chart below for exact size.)

### Straight Copper Piece

PART NO.	LENGTH	I.D.	O.D.
SF8418	1 7/8"	1 1/8"	1 1/4"
SF8434	1 5/16"	3/4"	13/16"
SF8478	1 9/16"	7/8"	1"

### Flared Copper Piece

PART NO.	LENGTH	I.D.	O.D.
SF8412	1 3/4"	1/2"	9/16"
SF8414	2 9/32"	1/4"	5/16"
SF8416	2"	5/16"	3/8"
SF8458	2"	5/8"	11/16"

## SF4040 Charging Hose Flow-Control Valve



- Reliable and easy to use
- Install on the end of a charging hose and minimize refrigerant loss during servicing
- A quarter turn of the handle makes quick work of turning on and off
- Straight flow through design offers maximum flow rate
- Brass depressor tip fully engages valve core

## SF1818 and SF1414 Brass Bodies



- Both bodies complete with neoprene seal, core and cap.
- Each is a quarter male flare above the hex.



## Valve Replacement Parts



PART NO.	DESCRIPTION
SF2235	Heavy duty hex brass cap with dual neoprene or metal seal
SF2245	Heavy duty round brass cap with neoprene seal
SF2250	Heavy duty round brass cap with handy core wrench on top and neoprene seal
SF4450	Valve core with neoprene seal compatible with most refrigerants (Replaces SF1515)
SF5161	5/16" OD neoprene hose gasket for charging hoses

# Valves & Fittings

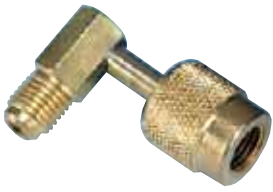

## Adapters/Couplers

Quick coupler valve depressors complete with leakproof neoprene seal and depressor tips. Use to make connection between equipment with unlike threads. Made of CDA 360 brass. Available in straight and 90° configuration.

PART NO.	DESCRIPTION
SF2010	1/4" female flare swivel x 1/4" male flare access, 90° configuration. Depressor tip and seal, no valve core.
SF2012	1/4" female flare swivel x 1/2" Acme male, depressor tip and seal
SF2020	1/4" female flare hex x 1/2" Acme male
SF2028	1/4" male flare x 1/2" Acme female swivel, depressor tip seal



## SF2035 Hose Gas Retaining Coupler

- 1/4" female flare retainer Sure-seal x 1/4" male flare

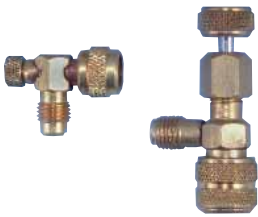

## SF2060 & SF5050 Thumbscrew Core Depressors

For use on a 1/4" male flare to allow the core to be opened to the degree of flow desired. Solid brass construction. Compact design makes it ideal in close quarters.

PART NO.	DESCRIPTION
SF2060	For 1/4" male flares.
SF5050	For 1/4" male flares. Made small for use in close quarters



## SF2070 Hose Gas Retainer and Core Depressor Tool

This tool is attached to a charging hose, then it is coupled to an access fitting. Thumb screw the depressor tip down to depress the core and allow gas to flow through the hose. Thumb screw back to allow the core to shut off. The depressor tip rod will back seat in a Teflon gasket to retain the gas in the hose. There will be no loss of the gas in the hose when you disconnect from the access fitting.



## SF2090 Hose Gas Retaining Coupler

- 90° 1/4" female flare retainer x 1/4" male flare



## SF2595 and SF2597 Gauge Adapter

**SF2595** A 1 1/4" piece of 1/4" copper tubing, double flared on one end with a 1/4" female flare nut and a depressor tip. The end of the copper tube opposite the female flare has been swaged to allow 1/4" copper tube to enter for brazing.

**SF2597** A 1 1/4" piece of 1/4" copper tubing, double flared on one end with a 1/4" female flare and a depressor tip. The other end has a 1/4" male flare that has been brazed on. A core may be inserted in the 1/4" male flare, but is not provided.



## Gauge Adapters

PART NO.	DESCRIPTION
SF5014	1/4" male flare to 3/16" fittings. Contains depressor pin.



## SF8725 Connector

The SF8725 has a gasket in the 1/4" hex nut. The valve body is stationary. When threads of existing system fittings are stripped and a new core won't go in, use this. It has a core and no depressor tip.

## Tee Connectors

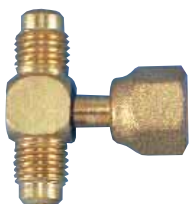

PART NO.	DESCRIPTION
SF9601	1/4" m. flare x 1/4" flare nut with depressor tip x 1/4" m. flare on the branch with one valve core
SF9602	1/4" m. flare with valve core x 1/4" m. flare x 1/4" f. flare nut with depressor tip on the branch
SF9603	All brass connector tee. 1/4" m. flare with valve core and cap x 1/4" m. flare x 1/4" f. flare nut with depressor tip on the branch

# Valves & Fittings

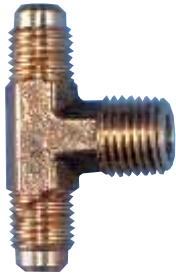

## SF9600 Series 1/4" Flare Forged Access Tees

- Forged brass tee
- All 1/4" flares are threaded for valve cores

PART NO.	SIZE	MPT END I.D.
SF9613	1/4" m. flare x 1/4" m. flare x 1/4" m. flare, two valve cores, no caps	
SF9614	1/4" m. flare x 1/4" MPT x 1/4" m. flare access on branch, one cap and one valve core	5/16" for brazing a copper tube
SF9615	1/4" m. flare x 1/4" m. flare x 1/4" MPT on branch, one cap and one valve core	5/16" for brazing a copper tube
SF9616	1/4" m. flare x 1/8" MPT x 1/4" m. flare access on branch, one cap and valve core	1/4" for brazing a copper tube
SF9620	1/4" m. flare x 1/4" m. flare x 1/8" MPT on branch, one cap and valve core	1/4" for brazing a copper tube



## SF9644 Connector

2 - 1/4" male flares, one with core and cap, in a "U" shape. At the side is a 1/4" female flare with depressor tip and opposite that is an additional 1/4" male flare

## Valve Tools



## SF3800 Chaser

- Two tools, a core wrench and thread chaser, complete with a core carrying case and six cores
- Length with core wrench lid 3 1/2"



## SF3813 Valve Core Remover/Container

- Heavy-duty, all brass
- Length is 3"
- Includes 3 valve cores



## Core Removal Tools\*

PART NO.	DESCRIPTION
SF3900	Designed for removing and replacing a "Schrader" type core, without losing the charge. All brass construction.
SF3910	Same as above with an additional side port (1/4" male flare) with core.

\* Not compatible with R-410A

## Core Removal Tools (with Ball Valve)\*



PART NO.	DESCRIPTION
SF3920	Removes a valve core from a 1/4" male flare access fitting without loss of refrigerant. Because it has a ball valve inside rather than a stem-type valve, the tool can be closed with just a quarter turn.
SF3930	Same as above with an additional port
SF5555	CRT repair kit (o-rings)

\* Not compatible with R-410A



## SF3970 Internal Temperature Reading Tool\*

(Measures -58°F to +302°F)

This two piece tool provides a better way of obtaining a temperature reading inside the system. It allows you to insert the digital thermometer through an access fitting, and you can adjust for superheat while you're inside. Furnished complete with core extractor tool and digital thermometer. Easy to follow instructions included.

Replaces SF3940 and SF3960

\* Not compatible with R-410A



## SF4311 "FasTap" Tube Piercing Pliers

Fast refrigerant recovery with pliers that clamp on and pierce tube. Pliers work on copper tubing sizes ranging from 1/4" to 7/8" OD. They are simple to use and light weight. Adjust pliers to proper size, align tip to the center of tube, clamp down and pierce with quick action. Piercing tip is self-sharpening, but also easily replaceable.



## SF4314 Tube Piercing Pliers Replacement Tip

# Condensate Drain Pans



## Commercial Condensate Evaporator Pans

For condensate applications where no drain is available, choose from these popular, large capacity sized pans. SUPCO commercial refrigeration condensate evaporator pans are made from top quality materials for durable, long life.

### Features/Benefits:

- CP804-HD 20 gauge stainless steel. All others use 22 gauge.
- Corrosion resistant stainless steel construction.
- Made from top quality materials and components for longer more durable use.
- Positive evaporation
- High limit safety and float switch operation
- Available In 120 volts, 208 volts and 240 volts
- Warranty-One Year from date of installation
- Space saving

### Applications:

- Evaporates defrost and condensation where no drain is available.
- Used in supermarket refrigeration systems and elevators.
- These pans are used for water dissipation **ONLY! DO NOT OPERATE "DRY"**.
- Clean the pan and check the float every 30 days for optimum performance and operation.



### Specifications

PART NO.	CAPACITY	VOLTS	WATTS	AMPS	DIMENSIONS		DISSIPATION RATE	
					L x W x H	PER DAY	REPLACES	
CP801	1 3/4 qt	120	400	3.3	10" x 7" x 2 1/2"	3 Gallon	DM04T1S	
CP802	2 1/2 qt	120	800	6.6	13" x 7" x 2 1/2"	6 Gallon	DM08S1S	
CP802-240	2 1/2 qt	240	800	3.3	13" x 7" x 2 1/2"	6 Gallon		
CP804	4 1/2 qt	120	1000	8.34	13" x 7" x 4"	10 Gallon	DM10MS1	
CP804-240	4 1/2 qt	240	1000	4.17	13" x 7" x 4"	6 Gallon		
CP804HD	7 1/2 qt	120	1000	8.34	13" x 10" x 4"	6 Gallon	DM10W1D	
CP804HD-240	7 1/2 qt	240	1000	4.17	13" x 10" x 4"	6 Gallon		
CP807	7 1/2 qt	120	1000	8.34	13" x 10" x 4"	10 Gallon	DM10W1S	
CP807-240	7 1/2 qt	240	1000	4.8	13" x 10" x 4"	10 Gallon	DM10W3	
CP815	15 qt	120	1440	12	21" x 13" x 4"	12 Gallon	DM15WW1D	
CP815-240	15 qt	240	1500	6.28	21" x 13" x 4"	12 Gallon	DM15WW3	
CP816	7 qt	120	500	4.17	13" x 10" x 4"	4.5 Gallon	DM05W1D	
CP817	7 qt	208	1000	4.81	13" x 10" x 4"	8 Gallon	DM10W2D	
CP818	7 qt	208	1000	4.81	13" x 10" x 4"	8 Gallon	DM10W2S	
CP819	7 qt	120	1500	12.5	13" x 10" x 4"	12 Gallon	DM15W1D	
CP820	7 qt	208	1500	7.21	13" x 10" x 4"	12 Gallon	DM15W2D	
CP821	7 qt	208	1500	7.21	21" x 10" x 4"	12 Gallon	DM15WW2D	

### Replacement Parts

PART NO.	FLOAT PART NO.	HEATER PART NO.	MICROSWITCH PART NO.	THERMOSTAT PART NO.
CP801	CPFLOAT	CPH801	CPS800	CPT800
CP802	CPFLOAT	CPH802	CPS800	CPT800
CP802-240	CPFLOAT	CPH802-240	CPS800	CPT800
CP804	CPFLOAT4	CPH8047	CPS800	CPT800
CP804-240	CPFLOAT4	CPH804-240	CPS800	CPT800
CP804HD	CPFLOAT4	CPH804HD	CPS800	CPT800
CP804HD-240	CPFLOAT4	CPH804HD-240	CPS800	CPT800
CP807	CPFLOAT4	CPH8047	CPS800	CPT800
CP807-240	CPFLOAT4	CPH807-240	CPS800	CPT800
CP815	CPFLOAT4	CPH815	CPS800	CPT800
CP815-240	CPFLOAT4	CPH815-240	CPS800	CPT800
CP816	CPFLOAT	CPH816	CPS800	CPT800
CP817	CPFLOAT	CPH817	CPS800	CPT800
CP818	CPFLOAT	CPH818	CPS800	CPT800
CP819	CPFLOAT	CPH819	CPS800	CPT800
CP820	CPFLOAT	CPH820	CPS800	CPT800
CP821	CPFLOAT	CPH821	CPS800	CPT800

Cross Reference on page 129

## 70 Condensate Drain

Authorized, cost effective replacement drain for most commercial refrigerators and freezers.

### Features/Benefits:

- PTC Control supplies only required heat to evaporate water.
- Thermostat and float NOT required
- Self regulating
- Uniform heating
- Die cast aluminum eliminates corrosion
- Removable cord set for easy cleaning
- Die cast aluminum eliminates corrosion
- Removable cord set for easy cleaning
- Low Profile(3") to fit tight spaces
- NSF, UL and CSA(wher noted) approved



PART NO.	CAPACITY	VOLTS	WATTS	AMPS	EVAPORATE. RATE	SIZE
70	50 oz	115	300	2.61	6 oz/hr	12 1/4" x 4 3/4" x 3"
70-220	50 oz	220	300	1.36	6 oz/hr	12 1/4" x 4 3/4" x 3"
70CSA*	50 oz	115	190	1.65	6 oz/hr	12 1/4" x 4 3/4" x 3"
70CSA220*	50 oz	220	190	.86	6 oz/hr	12 1/4" x 4 3/4" x 3"

\*CSA indicates CSA approval. \*\* All are 50/60 HZ

## 30-OS, 31 & 75 Condensate Drains

- Standard cast aluminum condensate drains complete with long life heating element and mounting legs.
- Designed for continuous use.



PART NO.	CAPACITY	VOLTS	WATTS	AMPS	EVAPORATE. RATE	SIZE
30-OS*	38 oz	120	160	1.33	8 oz/hr	10" x 4" x 2 7/8"
30-220-OS*	38 oz	220	160	.73	8 oz/hr	10" x 4" x 2 7/8"
31	50 oz	120	160	1.33	6 oz/hr	10" x 4 1/2" x 3 3/8"
31-220	50 oz	220	160	.73	6 oz/hr	10" x 4 1/2" x 3 3/8"
75	75 oz	120	320	2.67	14 oz/hr	10" x 9" x 2 3/4"
75-220	75 oz	220	320	1.45	14 oz/hr	10" x 9" x 2 3/4"

\* Indicates NSF listing \*\* All are 50/60 HZ

## Wall Mount Brackets

PART NO.	CONDENSATE DRAIN NO.
30WM	30-OS Series, 75 Series
31WM	31 Series

# Condensate Drain Pans

## DP34 Drain Plus HVAC Condensate Drain [Visit www.drainplus.com for complete information.](http://www.drainplus.com)

A drain solution defined for HVAC condensate lines. Negative coil pressure needs some type of drain trap. Drain Plus was developed specifically for this purpose.



### Features/Benefits

- Lifetime Warranty
- Prevents Dry Trap Syndrome
- Easy installation
- Removable cap for easy cleaning and inspection of the condensate line.
- Replaces conventional PVC P-Traps.

### Specifications

- 3/4" PVC
- Durable Schedule 40 PVC material.



## Drain Heaters

All SUPCO Drain and Door Heaters are designed for continuous use to protect drains against ice build up which leads to clogging. All of these heaters cannot be cut, spliced, extended or altered in any way.

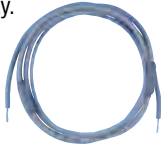

## SH200 Series Flexible Braided Aluminum Drain Heaters

### Features/Benefits

- Aluminum Construction
- Variety of Lengths and Wattage's Available

### Applications

- Domestic and Commercial Refrigeration
- Air Conditioner & Heat Pump Systems
- Condensate Drain Pans, Tubes and Troughs

Part numbers SH201 thru SH207

- Available in 220 Volts (Special Order)

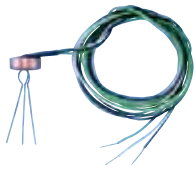

## SH250 Universal Drain Heater

### Features/Benefits

- Used With Existing Heater or Where No Heater Exists
- Available in 220 Volts (Special Order)

### Tech Tip

- The SH250 Universal Drain Heater is designed for "series wiring connection" only.

PART NO.	DIAMETER	PRONG	WIRE
		LENGTH	LEADS
SH250	0.91"	2.25"	56"



## SH250 Series Silicone Drain Heaters

### Features/Benefits

- Silicone Construction
- Designed For Waterproof Low Wattage Heat
- GE Serpentine Coil Heater Applications

Part numbers SH251 and SH252

### Tech Tip

- The SH252 Silicone Drain Heater is designed for "series wiring connection" only.
- SH251 replaces GE WR51X72, Frigidaire 6582706
- SH252 replaces Frigidaire 7517924



## SH500 Series Drain Heaters

### Features/Benefits

- Durable Metal Braid
- Available In 220 Volts (Special Order)
- Heater Tip 7/16" Diameter

Part numbers SH500 thru SH505

- Silicone Construction
- Designed For Waterproof Low Wattage Heat

## Foil Heaters



## SH220 Series Aluminum Foil Heaters

### Features/Benefits

- Pressure Sensitive Adhesive Backing For Easy Installation
- Six Assorted Shapes and Wattage's
- Available in 220 Volts (Special Order)

### Heater Specifications

PART NO.	VOLTS	WATTS	SIZE	PART NO.	VOLTS	WATTS	SIZE
SH201	115	15	18" 23"	SH250	120	3	
SH202	115	45	29" 23"	SH251	115	8	heater tip - 3"
SH203	115	55	44" 23"	SH281	120	3	36 1/2' ft.
SH204	115	75	48" 23"	SH282	120	3	18' ft.
SH205	115	65	56" 23"	SH283	220	3	36' ft.
SH206	115	80	70" 23"	SH284	220	3	18' ft.
SH207	115	110	86" 23"	SH500	120	11	9" 18"
SH221	115	6	10" x 1"	SH502	120	15	13" 18"
SH222	115	10	24" x 1 1/4"	SH503	240	15	13" 18"
SH223	115	10	14 1/2" x 5 1/2"	SH504	120	25	21" 18"
SH225	115	15	10 1/2" x 10 1/2"	SH505	240	25	21" 18"
SH226	115	40	10 1/2" x 10 1/2"				

### Applications

- Commercial & Domestic Refrigeration
- Mullions
- Drain Troughs
- Drain Pans
- Spot Heating

## Door Heaters



## SH280 Series Door Heaters Mullion & Dew Point

Part numbers SH281 thru SH284

### Features/Benefits

- Prevents Moisture on Glass Display Doors
- Eliminates Frost Build Up On Doors & Cabinet Fronts

### Applications

- Commercial & Domestic Refrigerators & Freezers

**Tech Tip** - These heaters are water resistant only, not water proof. These heaters can get wet, but they cannot sit in water for any period of time.

# Vacuum & Pressure Gauges



## VG64 Digital Vacuum Gauge

Suitable for field or laboratory use, the VG64 delivers high precision at a low price.

### Features/Benefits

- Ultra fine resolution: (1 Micron when vacuum  $\leq$  200 Microns)
- Reads vacuum in 7 international units
- Display updates every 1/2 second
- Convenient built in hanger
- Cleaning port provides quick cleaning and drying of sensor
- Low battery Indicator



### Accessories

#### PART NO.

10475 120 V Power Adapter

MFDCASE Soft Pouch

VGCVacuum Gauge Coupler



## VGC Vacuum Gauge Coupler

- Eliminates leaks during service



## VG64S Single Port Digital Vacuum Gauge

Same great features and specifications with single port connection.



See page 129 for Connection Application Note



## VG60 Electronic Vacuum Gauge

10 segment color coded LED readout provides fast response of vacuum measurements.

### Features/Benefits

- Pocket size—only 5 1/2" x 1 3/4" x 1 1/2"
- Cleanable sensor
- Single switch operation
- Low battery indication
- Color coded LED display
- Built-in hanger
- Soft case included (MFDCASE)



### Accessories

#### PART NO.

DPGT 120 V Power Adapter



## VG61 Electronic Vacuum Gauge

Enjoy the same features as the VG60 in a durable hard case. Sensor cord extends to 5 feet.

### Features/Benefits

- Cleanable sensor
- Single switch operation
- Low battery indication
- Color coded LED display



## VG65 Professional Series Digital Vacuum Gauge

Same great specifications as the VG64 in a rugged service case.

### Features/Benefits

- Extendable service card



## VG66 Professional Series Analog Vacuum Gauge

### Features/Benefits

- Vacuum range 50 – 5000 microns
- 5 inch Analog meter
- Cleanable Vacuum Sensor
- 500 psi maximum overpressure
- Low battery indicator
- Expandable sensor cord (up to 6 feet)
- Sensor cord extendable using standard telephone cord
- Rugged Service case



# Vacuum & Pressure Gauges

## Vacuum Gauge Specifications

	VG64/VG64S	VG60	VG61	VG65	VG66
Sensor Type	Thermistor	Thermistor	Thermistor	Thermistor	Thermistor
Connector Type	Standard 1/4" male flare fitting.	Standard 1/4" male flare fitting.	Standard 1/4" male flare fitting.	Standard 1/4" male flare fitting.	Standard 1/4" male flare fitting.
Vacuum Range	0 – 12,000 Microns (0 – 1,600 Pascals)	50 – 5,000 Microns	50 – 5,000 Microns	0 – 12,000 Microns (0 – 1,600 Pascals)	10 – 5,000 Microns
Scale	Microns, PSI, InHg, milliBars, Pascals, Torr, milliTorr	Microns - 10 LED segments atmosphere to 50 Microns	Microns - 10 LED segments atmosphere to 50 Microns	Microns, PSI, InHg, milliBars, Pascals, Torr, milliTorr	Microns, Torr
Resolution	0-200: 1 Micron 201-500: 5 Microns 501-1,000: 10 Microns 1,001-2,000: 50 Microns 2,001-5,000: 250 Microns 5,001-8,000: 500 Microns 8,001-12,000: 1,000 Microns			0-200: 1 Micron 201-500: 5 Microns 501-1,000: 10 Microns 1,001-2,000: 50 Microns 2,001-5,000: 250 Microns 5,001-8,000: 500 Microns	
Operating Temperature Range	35°F to 125°F ( 2°C to 52°C)		35°F to 125°F ( 2°C to 52°C)		
Overpressure	500 PSI Max (20 Bar)	500 PSI Max (20 BAR)	500 PSI Max (20 BAR)	500 PSI Max (20 BAR)	500 PSI Max (20 BAR)
Accuracy	±10% (100-1000 Microns)			±10% (100-1000 Microns)	
Power Source	9 V Battery (not included)	9 V battery (not included)	9 V battery (not included)	9 V battery (not included)	9 V battery (not included)
Auto Shutoff	Yes	No	No	Yes	N/A
Dimensions	5 1/2" x 3" x 1 1/4"	5 1/2" x 1 3/4" x 1 1/2"	9 1/2" x 6 3/4" x 2 3/4"	5 1/2" x 3" x 1 1/4"	9 1/4" x 7 1/2" x 2 3/4"
Weight	6.7 oz	6.8 oz	1.8 lbs.	1 lb 11 oz	2 lbs 6 oz

## DPG25V/DPG100/DPG1000 - Digital Pressure Gauges



MADE IN THE USA



The DPG Series are digital pressure gauges featuring multiple units, selectable zero reference and automatic power off to conserve battery power. The DPG100/DPG1000 can be used with any media compatible with 17-4PH stainless steel.

### Features/Benefits

- High Accuracy
- Measurement Units PSI, Bar, Kg/cm , ATM
- Easy To Use
- Stainless Steel Sensor
- No Welds or "O" Rings
- 1/8 NPT Female Connection
- Long Battery Life
- 1 Hour Auto Off

### Applications

- HVAC Refrigerant Lines
- Steam Pipes
- Process Piping
- Compressed Air Lines
- Specialty Gas Piping

### Product Specifications

	DPG25V	DPG100	DPG1000
Pressure Range	-14.7 to 25 PSI	-14 to + 100 PSI	-14 to + 1000 PSI
Measurement Units	InHg PSI Kg/cm, ATM	PSI, BAR, Kg/cm, ATM	PSI, BAR,
Resolution PSI	0.1	0.1	1.0
InHg	0.01	*	*
BAR	*	0.01	0.1
Kg/cm	*	0.01	0.1
Atm	*	0.01	0.1
Accuracy	< ± 0.5% BFSL (includes Non-linearity, Hysteresis and Non-repeatability)		
Stability (1 year)	±0.25% FS (typ)		
Overrange Protection	2X Rated Pressure		
Burst Pressure	5X or 20,000 psi whichever is less.		
Pressure Cycles	>100 Million		
Operating Temperature Range	32°F to 130°F (0°C to 55°C)		
Storage Temperature Range	-40°F to 150°F (-40°C to 65°C)		
Compensated Temperature Range	32°F to 130°F (0°C to 55°C)		
Temperature Compensation Zero	< ±1.5% of FS		
Temperature Compensation Span	< ±1.5% of FS		
Pressure Sensor Connection	1/8 NPT Female		
Update Rate	3 Samples per Second (typ)		
Power	9 Volt Alkaline Battery		
Automatic Power Off	1 Hour		
Battery Life 100 Hours Continuous Operation (typ)			

# Temperature, Humidity Testers & Thermometers

## Infrared Thermometers



### PIT1

- 1:1 Optical Ratio
- Pocket Size
- Min/Max Measurements



### LIT6

- 6:1 Optical Ratio
- Laser Pointer
- Backlight



### LIT8B

- 8:1 Optical Ratio
- Laser Pointer
- Trigger Style
- Backlight
- Minimum/Maximum Measurements



### LIT11TC

- 11:1 Optical Ratio
- Laser Pointer
- High & Low Temperature Range
- Backlight
- Carrying Case Included
- K-Type Thermocouple (probe included)
  - Temperature Range 58°F to 482°F (14°C to 250°C)
  - Full range: -83.2°F to 1999°F (-64°C to 1400°C)
  - Temperature Accuracy  $\pm 1\%$  of reading or 2°F

Laser Infrared Thermometers offer precise, non-contact measurement in a lightweight, hand held instrument. With one hand operation, they are ideal for a wide variety of applications.

### Applications

- Refrigeration Systems
- Heating Systems
- Supply and Return Registers
- Circuit Breaker Panels
- Motors/Bearings
- Transformers
- Ducts
- And More

### Application Note:

#### What is Distance to Spot Ratio (D:S)?

This is the size of the measurement field that a non-contact infrared thermometer uses to provide a temperature reading. The infrared thermometer averages the temperature of that field to calculate the temperature reading. For example, a D:S ratio of 8:1 means that the measurement field measures approximately 1 foot in diameter when the target is approximately 8 feet away.

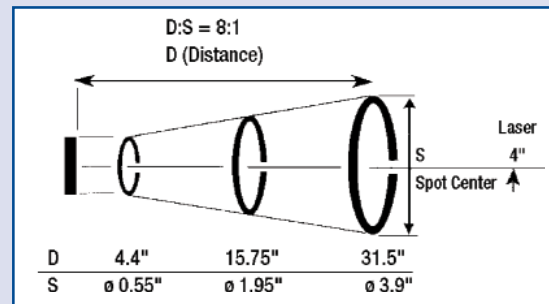

### Emissivity:

The ability of a surface to reflect the infrared radiation relative to an ideal surface. A flat black surface is as close to ideal as you can get. Most infrared thermometers have a fixed emissivity of .95. The more reflective the surface the lower the emissivity adjustment should be.

## Infrared Specifications

	PIT1	LIT6	LIT8B	LIT11TC
Optical Ratio	1:1	6:1	8:1	11:1
Temperature Range	-27°F to 428°F (-33°C to +220°C)	0°F to 500°F (-18°C to 260°C)	-4°F to 662°F (-20°C to 350°C)	-76 °F to 932°F (-60°C to 500°C)
Best Resolution	.1°F (.1°C)	.1°F (.1°C)	1°F (1°C)	.1°F (.1°C)
Accuracy	$\pm 2\%$ of reading or +4°F (2°C)	$\pm 2\%$ of reading or +4°F (2°C)	$\pm 2\%$ of reading or $\pm 4\text{°F}$ (2°C)	$\pm 2\text{°F}$ ( $\pm 1\text{°C}$ )
Emissivity	0.95 adjustable	0.95 fixed	0.95 fixed	0.95 adjustable
Automatic shut off	Yes	Yes	Yes	Yes
Power Supply	CR2032 (Included)	9V Battery (Not Included)	9V Battery (Included)	2 AAA Batteries (Included)
Weight	1.3 oz. (32g)	5.3 oz. (150g)	5.8 oz. (180g)	6.3 oz. (179g)
Dimensions	.7" X 1.5" X 2.7" (18mm X 37mm X 68mm)	5.1" X 2" X 1.25" (18mm X 50mm X 42mm)	6.4" X 3.2" X 2.4" (159mm X 79mm X 57mm)	6.9" X 1.5" X 2.8" (175 X 39 X 71mm)

# Temperature, Humidity Testers & Thermometers



## DSP1000 Digital Psychrometer

The DSP1000 provides fast, accurate measurements for analysis of critical environmental conditions.

- Temperature
- Humidity
- Fast Response
- Dual Display
- Max Hold
- No Twirling
- No Reading Charts
- No Water Necessary

### Features

- Fast Response Time
- High Accuracy
- Temperature
- Humidity
- Dewpoint Temperature
- Wet Bulb Temperature
- Max Hold
- Data Hold Function
- Micro Processor-based Design
- Dual Display Temperature & Humidity
- Auto Power Off (Disable Sleep Mode)
- Backlight
- 1 Year Warranty

### Applications

- Cellophane
- Chemical
- Laboratory
- Pharmaceuticals
- Textile
- Paper
- Photographic
- Printing
- Snowmaking
- Tobacco
- Indoor Air Quality
- Wine Storage
- Floral
- Meat

### Specifications

RANGE	
Humidity	0-100% RH (Non-Condensing)
Temperature	-22°F to 212°F (-30°C to 100°C)
Dewpoint Temperature	-22°F to 212°F (-30°C to 100°C)
Wet Bulb Temperature	32°F to 176°F (0°C to 80°C)
ACCURACY	
Humidity	±2% RH (20% RH to 80% RH) ±2.5% RH (all other ranges)
Temperature	±0.9°F/±0.5°C (at 77°F/25°C) ±1.5°F/±0.8°C (all other ranges)
Resolution	0.01% RH, 0.01°F/0.01°C
Response Time	10s (90% at +77°F (+25°C) still air)
Battery Type	9V Battery NEDA 1604, IEC 6F22 (included)
Operation Temperature	32°F to 104°F/0°C to 40°C (<80%RH)
Storage Temperature	14°F to 140°F/-10°C to 60°C (<70%RH)
Size (H X W X D)	8.86" X 1.77" X 1.34" (225mm X 45mm X 34mm)
Weight	7.05oz (200g)



## DDT2 Digital Differential Thermometer

With its Dual Display, the DDT2 provides instant measurements for two Temperature points (T1,T2) and their difference (T1-T2).

### Features/Benefits

- Dual K-Type Thermocouple Inputs
- Temperature Differential Measurement (T1-T2)
- Records Up to 8 Min/Max/Avg Measurements
- Relative Function provides instant Temperature Difference between successive measurements
- Dual Display
- Auto-Ranging
- Data Hold
- Auto Power Off
- Vinyl Case Included

### Applications

- Superheat Measurements (T1-T2)
- Ambient Temperature Measurements
- Food Service
- Oven Temperature measurements
- Surface Temperature Measurements
- Measure HVAC and Refrigeration System Temperatures

## PT100 Digital Pocket Surface Thermometer



### Features/Benefits

- Ultra sensitive air and surface reading probe
- Provides fast response—within seconds
- Temperature "HOLD" switch—keeps readings fixed

### Applications

- Speedy recovery - reclaim temperature measurement
- Measures evaporator plate and condensing temperatures
- Air inlet, outlet and surrounding air

PART NO.	DESCRIPTION
PT100	Fahrenheit Model
PT100C	Celsius Model
PT100H	High Temp. Fahrenheit
PT100HC	High Temp. Celsius

# Temperature, Humidity Testers & Thermometers

## Temperature and Humidity Tester Specifications

	DDT2	PT100	TPM110	THP2	THC120	STD5-105
# of inputs	2	1	1	1 Temp./1 Hum.	1 Temp./1 Hum.	1
Thermo - couple Type	K		J			
Differential	*					
Data Hold	*	*				
Min/ Max	*				*	
Dual Display	*				Triple Display	
Auto-Off	*					
Temp. Range	-328°F to 2498°F -200°C to 1370°C	PT100/PT100C -40°F to 199.9°F -40°C to 93.28°C PT100H/PT100HC -40°F to 250°F -40°C to 120°C	-70°F to 199°F -56.67°C to 93.28°C	-4°F to 122°F -20°C to 50°C	+32°F to 120°F 0°C to 50°C	-60°F to +160°F -51°C to 107°C
Temp. Resolution	0.1°F -200°F to 200°F 1°F otherwise	0.1°F -40°F to 199.9°F 1.0°F (-40° to 250°F)	1.0°F	0.1°F	0.1°F	0.1°F
Temp. Accuracy	±0.5% Rdg+2°F	0.2 Surface 1.0 Air	±1°F	±2°F	±1.8°F or 1.0°C	
Humidity Range				10% to 90% RH	+10% to 9% RH	
Humidity Resolution				1% RH	1% RH	
Humidity Accuracy				±5% for -40% to 80% RH otherwise	±5% RH ±8%	
Power	9V Alkaline	9V Alkaline	120/240V 50/60 Hz	Button cell (1) LR44	AAA (1) Batteries	Solar
Size (HxLxW)	7.25" X 2.5" X 1.4"	1.5" X 6.75" X 0.8"	3.38" X 3.38"	6.5" X 1.75" X .6"	3.75" X 4 1/8" X 7/8"	4 1/2" X 1 1/8" X 9/16"
Weight	7.2 oz	7.2 oz	7.4 oz	2 oz	3 oz	2 oz
Warranty	1 year	1 year	1 year	1 year	1 year	1 year

## K-Type Thermocouple Probes



TPFDA



TPP



TPS

### Temperature Probe Specifications

	TPFDA	TPP PIERCING	TPS SURFACE
Temp. Range:	-40°F to 550°F -40°C to 288°C	-58°F to 482°F -50°C to 250°C	-58°F to 1202°F -50°C to 650°C
Subminiature connector	*	*	*
4' bead tip probe with FDA approved insulation	*		
3.7" heavy duty chisel tip insertion probe with handle and 4' cord			
4" heavy duty spring loaded tip surface probe with handle and 4' cord		*	

## STD5-105 Solar Powered Digital Thermometer



### Features/Benefits

- -60°F to +160°F
- -51°C to 107°C
- 36" Probe Length
- Selector Switch for °F or °C
- 4 1/2" W x 1 1/8" H x 9/16" D
- 3/8" High LCD Display
- 10 Second Update

### Applications

- Refrigerator/Freezer
- Food Processing
- Environmental Temperature Measurement



# Temperature, Humidity Testers & Thermometers



## THP2 Thermo-Hygrometer Pen

### Features/Benefits

- Measures Temperature & Humidity, Simultaneously
- Dual Display
- Temperature in °F or °C
- Pocket Clip
- Battery Included
- Min/Max Memory



## THC120 Indoor Digital Thermo-Hygrometer w/ Clock

### Features/Benefits

- Table top or wall mount
- Measure Temperature and Humidity Simultaneously
- Real Time Clock
- Large Display
- Temperature Range: 32°F to 120°F (0°C to 50°C)
- Humidity Range: 10% to 90%
- °F/°C Switchable
- Min/Max Temperature and Humidity memory function



## TPM110 Temperature Indicator

A highly reliable, extremely accurate temperature indicator. Custom designed faceplates with your company name or logo are available with quantity orders.

### Features/Benefits

- Large LCD display
- Easy installation
- Thermocouple wire can be extended to 500'
- Can calibrate in the field

### Applications

- Direct replacement for old style 2 1/4" and 2 1/2" dial gauges
- Commercial Refrigeration/Freezer Panels
- Hospital/Laboratory Control Panels

### PART NO.

TPM110 110 VAC Fahrenheit Model

### Specifications

Ambient Operating Range	32°F to 150°F
Line Voltage	120 VAC
Probe	Encapsulated Sensor w/6' long cord
Case	High Impact Thermoplastic
Scale	-40°F to 199°F (-40°C to 93.28°C)

## Pocket Digital Thermometers

### ST09



- -40°F to 392°F (-40°C to 200°C)
- Accuracy:  $\pm 2^\circ\text{F}$  Full Scale
- Min/Max
- °F/°C Switch
- Protective Sheath
- Data Hold

- ON/OFF Switch
- Pocket Clip
- Battery Included (STBAT)
- Drop Resistant
- Waterproof
- 2 1/2" Long Stem
- Auto Off (20 min.)

### Applications

- Refrigerators/Freezers
- Food Processing/Prep.
- Heating/Ventilating

### ST10



- -50°F to 392°F (-45°C to 200°C)
- Accuracy:  $\pm 2^\circ\text{F}$  or  $\pm 1^\circ\text{C}$
- °F/°C Switch
- Large LCD
- Display updates every second

- Battery included. Free Spare Battery (STBAT)
- Pocket Clip
- 4 23/32" (12cm) Stainless Steel Stem

### Applications

- Refrigerators/Freezers
- Food Processing/Prep.
- Heating/Ventilating

## Pocket Dial Thermometers

### ST01/ST02

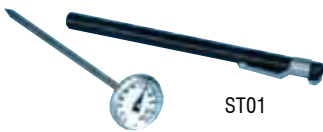

- 1" dial
- 5" stem
- °F only
- Recalibration adjustment

- Temperature Range:  
**ST01** -40°F to 160°F  
**ST02** 0°F to 220°F

### Application

- Refrigerators/Freezers
- Air Conditioners

### ST07/ST08

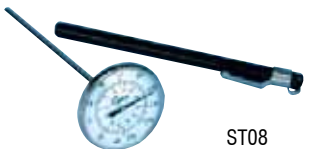

- 1 3/4" dial
- 5" stem
- °F and °C
- Recalibration adjustment

- Temperature Range:  
**ST07** 0°F to 220°F (-18°C to 105°C)  
**ST08** -40°F to 160°F (-40°C to 70°C)

### Application

- Air Conditioners
- Refrigerators/Freezers

## Appliance Thermometers

### ST03/ ST04

- Stainless Steel Construction
- Hangs or stands
- °F and °C
- Unbreakable lens

### ST06

- Horizontal design
- °F and °C

PART NO.	TEMPERATURE RANGE	APPLICATION
ST03	-20°F to 80°F (-30°C to 27°C)	Refrigerators
ST04	100°F to 600°F (38°C to 315°C)	Ovens
ST06	-40° to 80°F (-40° to 27°C)	Refrigerators/Freezers

- Stainless steel wire clips for easy hanging



# Temperature Alarms & Controls

## TA Series Temperature Alarms



All of your temperature sensitive areas are protected with the broadest line of temperature alarms: single and dual set point, wireless remote, battery operated and multi-channel. Select the right one for your application.

### Features/Benefits

- Adjustable alarm temperature ranges
- Audible and visual alarm
- Built-in terminals for remote alarm or telephone dialer connection (except TA7)
- Alarm switch for 'No delay' or '1 hour delay'

### Applications

- Food Markets, Convenience Stores, Supermarkets
- Restaurants, Florists, Greenhouses
- Laboratories, Pharmaceutical Storage Facilities
- Refrigerated Transport, Cold Storage Facilities
- Computer



### TA22

#### Digital Display Single Set Temperature Alarm

The easy to read display features Current Temperature, Alarm Status, Over/Under mode indicator, Alarm Set Point and Temperature Units (°F or °C).

- Adjustable range from -40°F to +160°F (-40°C to +71°C)
- AC Adapter included
- 80 db Audible Alarm



### TA2

#### Single Set Point Temperature Alarm

A reliable, inexpensive alarm for refrigerators and freezers. Just flip a switch to activate alarm on a rise or fall in temperature.

- Adjustable range from -10°F to +80°F (-25°C to +30°C)
- 90 db audible alarm
- AC Adapter included

MODEL NO.	
TA2	120 VAC Fahrenheit Model
TA2C	120 VAC Celsius Model
TA2-220	220 VAC Fahrenheit Model
TA2-220C	220 VAC Celsius Model



### TA6

#### Dual Set Point Temperature Alarm

Alarms on a rise **AND** fall in temperature.

- Adjustable Range from -10°F to +80°F (-25°C to +30°C)
- 90 db Audible Alarm
- AC Adapter included

MODEL NO.	
TA6	120 VAC Fahrenheit Model
TA6C	120 VAC Celsius Model
TA6220	220 VAC Fahrenheit Model
TA6C220	220 VAC Celsius Model



### TA7

#### Battery Operated Temperature Alarm

For sensitive temperature applications in remote areas, this battery operated unit is inexpensive and easy to install. Alarms on rise in temperature only.

- Adjustable Range from -10°F to 80°F (-25°C to 30°C)
- 70 db Audible Alarm

MODEL NO.	
TA7	Fahrenheit Model
TA7C	Celsius Model

### Temperature Alarm Specifications

	TA2	TA6	TA7	TA22
Alarm Channels	1	1	1	1
Alarm Adjustment Range	-10°F to 80°F (-25°C to 30°C, Celsius model)	-10°F to 80°F (-25°C to 30°C, Celsius model)	-10°F to 80°F (-25°C to 30°C, Celsius model)	-40°F to 160°F (-40°C to 71°C)
Probe	Encapsulated sensor with 6 ft. cord	Encapsulated sensor with 15 ft. cord	Encapsulated sensor with 6 ft. cord	Precision thermistor with 6 ft. cord
Sensor Type	Thermistor	Thermistor	Thermistor	Thermistor
Maximum Probe extension	200 ft.	200 ft.	100 ft.	200 ft.
Temperature Accuracy (Display)	±2°F (+/- 1°C)	±2°F (+/- 1°C)	±2°F (+/- 1°C)	±2°F (+/- 1°C)
Remote Alarm Connections	Screw type, 120 VAC, 5 Amp (dry contacts)	Screw type 120 VAC, 5 Amp max., (dry contacts)	None	Screw type, 120 VAC 5 Amp max
Power	120 VAC (220 V optional)	120 VAC (220 V optional)	9 V alkaline battery (not included)	120 VAC (220 V optional)
Case	Hi-impact thermoplastic	Hi-impact thermoplastic	Hi-impact thermoplastic	Hi-impact thermoplastic
Mounting	Surface, external holes provided	Surface, external holes provided	Surface, adhesive pads/ key hole slot	Surface, external holes provided
Dimensions	3" x 4 7/8" x 1 5/8"	3" x 4 7/8" x 1 5/8"	5 3/4" x 1 1/2" x 1"	3" x 5" x 1 1/2"
Weight	13 oz	13 oz	5 oz	13 oz
Warranty	1 year	1 year	1 year	1 year

# Temperature Alarms & Controls



## THA2 Temperature Humidity Alarm with logging capability

The THA2 is a multi-function product that monitors Temperature, Humidity and Dew Point, provides alarms for out of range conditions and continuously logs data. No computer setup is needed.

### Benefits

Measures and Logs

- Temperature
- Humidity
- Dew Point

### Applications

- Food Markets, Convenience Stores, Supermarkets
- Restaurants, Florists, Greenhouses
- Laboratories, Pharmaceutical Storage Facilities
- Refrigerated Transport, Cold Storage Facilities
- Computer Rooms

### Features

- Audible and Visual Alarm for Temperature, Humidity and Dew Point (condensation)
- Digital Display
- Log up to 170 Days of Data
- Relay Contacts for Remote Alarm or Auto Dialer (ADTA)
- PC Software Included
- Serial Port Connection (for USB connection use optional USBS adapter)
- Remote Sensor Up to 300 ft

### REPLACEMENT PROBE

**THA2P** 15' Cable Length

### ACCESSORIES

**19994** 100' Cable Extension

**19955** 300' Cable Extension

## THA2 Specifications

Stand alone front panel operation, with user lockout for security. PC software is provided with the unit for viewing data history.

SENSOR PROBE	
Operating Temperature Range	-40°F to 140°F (-40°C to 60°C)
Operating Humidity Range	0 to 95% RH, non condensing
Temperature Accuracy	±2°F (+/- 1°C)
Temperature Resolution	0.1°F or °C
Humidity Accuracy	±2% RH
Humidity Resolution	0.1% RH
Calibration	User calibration for Temperature and Humidity
Dimensions	3.8"L x 1.1"D
Weight	0.9 oz.
Cable Length 15' Included	300 ft. maximum
BASE UNIT	
Operating Temperature Range	32°F to 130°F (0°C to 54°C)
Storage Temperature	0°F to 130°F (-18°C to 54°C)
Operating Humidity	0% RH to 95% RH, non condensing*
Power Source	12V to 24 VAC/VDC, 0.78W alarm active
Battery Backup	9V alkaline battery for 35 hours operation during power outage
Clock Battery	CR2032, 10 years typical
Relay	N.O and N.C dry contact 5A 250V, resistive load
Dimensions	5.5" x 4.5" x 1.6"
Weight (without battery backup)	8.6 oz.

ALARM SPECIFICATIONS	
Temperature Alarm	High and Low Temperature and Humidity alarms. Condensation alarm
Alarm Delay	User selectable, up to 2 hours
Alarm Indication	Audio, Visual and a relay for remote alarm and phone dialer
LOGGING SPECIFICATIONS	
Sample Rate	1 second to 30 minutes
Data History Storage	2 hours to 170 days, depending on the sample rate
Memory Capacity	8150 samples for Temperature, Humidity and Dew Point

\* The sensor probe is not designed for continuous exposure to high humidity or caustic and or corrosive chemicals such as, but not limited, to concrete or chlorine.



## ADTA Auto Dialer For Temperature Alarms

- Call up to 4 telephone numbers
- 16 second message
- Non-Volatile memory for numbers and voice message
- Internal 9V back up battery (not included)
- LCD display
- 120V power adapter (included)

### Temperature Alarm Accessories

### Temperature Alarm Accessories

		TA2	TAL2	TA4	TA6	TA7	TA3	TAP4		TA2	TAL2	TA4	TA6	TA7	TA3	TAP4
<b>SW25</b>	25' Extension Wire	*	*	*	*	*	*	*	<b>11093</b>	Probe w/ 6' extension wire	*	*				
<b>SW50</b>	50' Extension Wire	*	*	*	*	*	*	*	<b>TA7PROBE</b>	Probe w/ 4' extension wire				*		
<b>SW75</b>	75' Extension Wire	*	*	*	*	*	*	*	<b>14265</b>	Replacement Sensor		*			*	
<b>SW100</b>	100' Extension Wire	*	*	*	*	*	*	*	<b>USBS</b>	USB to Serial Interface		*				
<b>TCW25</b>	25' Type J Thermocouple Wire			*			*		<b>13495</b>	Serial Port Cable		*				
<b>TCW50</b>	50' Type J Thermocouple Wire			*			*		<b>ADTA</b>	Auto Dialer	*	*	*	*	*	
<b>TCW75</b>	75' Type J Thermocouple Wire			*			*		<b>14263</b>	120 V Power Adapter (Supplied)	*		*		*	
<b>TCW100</b>	100' Type J Thermocouple Wire			*			*		<b>20540</b>	Replacement Sensor	*		*			
<b>TA3P</b>	Probe w/ 6' Type J Thermocouple Wire						*			6' new style metal tip (after serial #) 405-099				412-029		

# Temperature Alarms & Controls



## TAP4 Four (4) Probe Temperature Alarm

Set alarms for 4 separate temperature applications. Provides a quick alert for a multitude of temperature problems.



PART NO.	
TAP4	-40°F to 60°F; 0°F to 100°F, 120V
TAP4-220	-40°F to 60°F; 0°F to 100°F, 220V
TAP4C	-18°C to 38°C; -40° C to 16°C, 120V
TAP4C-220	-18°C to 38°C; -40° C to 16°C, 220V

### TAP4 Specifications

TAP4	
Alarm Channels	4
Alarm Adjustment Range	-40°F to 60°F and 0°F to 100°F (-18°C to 38°C and -40°C to 16°C, Celsius model)
Probe (14265)	Encapsulated sensor with 15 ft. cord (4 included)
Sensor Type	Thermistor
Maximum Probe extension	300 ft.
Remote Alarm Connections	Terminal strip screw connection 120VAC, 5 Amp max., (dry contacts)
Power	110V or 220V power adapter supplied
Battery Backup	9V alkaline battery (not included)
Case	NEMA 3 Type
Mounting	Surface, keyhole or recessed screws
Dimensions	6" x 7 1/2" x 3"
Weight	1.9 Lbs (0.86kg)
Warranty	1 year



## TA3 Digital Temperature Alarm

This panel mounted temperature alarm with digital display provides both an audible and visual alarm.

Alarms on rise or fall in temperature.

- Adjustable Range from -50°F to +170°F (-25°C to +96°C)

PART NO.		
TA3	120 VAC	Fahrenheit Model
TA3C	120 VAC	Celsius Model
TA3-220	220 VAC	Fahrenheit Model
TA3C220	220 VAC	Celsius Model

### TA3 Specifications

TA3	
Alarm Channels	1
Alarm Adjustment Range	-50°F to 170°F (-30°C to 96°C, for Celsius model)
Probe	Encapsulated sensor with 6 ft. cord (TA3P)
Sensor Type	J-Type Thermocouple
Maximum Probe extension	2000 ft.
Remote Alarm Connections	Screw type 120 VAC, N.O., 0.1 Amps max., (dry contacts)
Power	120 VAC (220 V optional)
Battery Backup	9V alkaline battery (not included)
Case	Panel Mount (1 3/4" x 3 5/8" cut out required)
Dimensions	1 11/16" x 3 9/16" x 5 3/16"
Weight	24 oz
Warranty	1 year



## TAL2 Dual Temperature Alarm Logger

Set high and low alarms for two (2) temperature sensitive applications, and track their temperature trends, simultaneously.

### Logger Functions

- Programmable interval (1 sec. to 18 hrs.)
- Data rollover
- Store 32,250 (single temp.) or 16,125 (dual temp.) data points
- Battery backup
- Software and cable included
- Minimum System Requirements: 8MB of RAM, 2M of disk space, 800 x 600 resolution, 1 free COM port or a free USB port (optional USB interface is required, p/n USBS)

### Alarm Functions

- Adjustable Range from -50°F to 86°F (-45°C to 30°C)
- Audible alarm & Relay contacts
- Relay contacts can connect to remote alarm dialer
- Programmable alarm delay
- Alarm event storage (up to 45 events)



### TAL2 Specifications

TAL2		TAL2	
Alarm Channels	2	Power	110V or 220VEU power adapter supplied (p/n 14950)
Alarm Adjustment Range	-50°F to 86°F (-45°C to 30°C)	Battery Backup	9V alkaline battery (not included)
Accuracy	±2%	Case	Hi-Impact thermoplastic
Probe (p/n 14265)	Encapsulated sensor with 15 ft. cord	Dimensions	3" x 2.5" x 1.1"
Sensor Type	Thermistor	Weight	2.5 oz
Maximum Probe extension	300 ft.	Warranty	1 year
	48 volts, 100mA maximum	Remote Alarm Connections	Normally Open (N.O.) Closed on alarm.

# Specialty Meters



## M500 Insulation Tester/Electronic Megohmmeter

An inexpensive alternative to expensive taut band (swing needle) megohmmeters, the M500 provides fast and accurate measurements to verify the condition of insulation.



### Features/Benefits

- Measure insulation values up to 1000 megohms @ 500 VAC
- Zone scale to indicate insulation condition
- Hand held
- Test Leads store in case
- Operates on 2 C batteries (not included)
- Impact resistant
- Soft carrying case included

### Applications

- Test motor winding insulation and diagnose heat damaged, deteriorating insulation in...
- Hermetic Refrigeration compressors
  - Appliances
  - Panel boards
  - Relay control circuits
  - Motors

### Specialty Instrument Selection Guide

- Measurement/Function - Insulation Resistance
- Range - 20 to 1000 megohms

### Standard Accessories

#### PART NO.

MCASE Soft Case



## M501 Insulation Tester/Electronic Megohmmeter

Enjoy the same great features of the M500 in a sturdy service case.



### Specialty Instrument Selection Guide

- Measurement/Function - Insulation Resistance
- Range - 20 to 1000 megohms

### Application Note:

#### Testing HVAC and Refrigeration Compressors and Motors

Many HVAC and Refrigeration motors require special test parameters since the winding operates in an oil and refrigerant atmosphere.

In a hermetic motor, under normal conditions the oil and refrigerant have a high electrical resistance. However, when they are contaminated with moisture, the electrical resistance changes and a low megohm reading of the winding terminal to ground may actually be the resistance of the contaminants in the oil and not in the winding insulation.

Newer motors have an insulation resistance value of more than 100 megohms, typically. Measurements of 50 megohms or less indicate a problem. Either the winding insulation is deteriorating or the oil/refrigerant is contaminated.

Installing an oversized drier may clean up the system or another possible solution could be replacing all the compressor oil. In either case, if the megohm tests show even the slightest improvement in resistance values the remedy may have checked a declining condition.

A good 'rule of thumb' is to smell a small sample of the oil. If the motor was ever severely overloaded, it will leave a tell tale trace in the oil that can only be removed by changing all of it.

The odor of burnt insulation is easily recognized and a low resistance value of 20 megohms or less will verify that the motor insulation may be severely damaged.



## MFD10 Digital Capacitor Tester

With one hand operation, the MFD10 provides the fastest measurements for capacitor values.



### Features/Benefits

- Range 0.01 to 10,000 mF
- Accuracy  $\pm 5\%$
- Test clip storage within case
- Alligator clips to capacitor terminals
- LED display
- One button operation
- Operates on one 9V Battery (not included)
- Soft carrying case included

### Applications

- Verification of Start and Run Capacitors
- Checks for open and short capacitors
- Identify unmarked capacitors
- Confirms weak capacitors
- Use as continuity tester

### Specialty Instrument Selection Guide

- Measurement/Function - Capacitance
- Range - 0.01 to 10,000 MFD

### Standard Accessories

#### PART NO.

MFD\_CASE Soft Case

MFD\_FUSE Fuse

# Specialty Meters

## DAVM+ Digital Air Flow/Volume Meter

Measure Air Flow (FPM) and Volume (CFM) in the palm of your hand. Compact and easy to use, the DAVM+ also measures Temperature, Humidity and Light. Ideal for air balancing and other indoor air quality applications.

### Features/Benefits

- Measures Feet per Minute (FPM) and Cubic Feet per Minute (CFM)
- Easy CFM Set-Up Flow Chart with Grille Free Area Chart (Included)
- Measures Temperature and Humidity
- °F/°C Selectable
- Standard K-Type Thermocouple Connector
- Measures Light Levels (LUX)
- Multi-Channel Display
- Data Hold
- One-Hand Operation
- Carrying Case (SCASE) Included

### Applications

- Identify Air Flow Problems
- Air Quality
- Air Balancing
- Measure Light Levels

### General Specifications

Measurement	Anemometer, Humidity, Temperature, Light, Air flow (CFM/CMM).
Operating Humidity	80% RH Max
Operating Temperature	32° to 122°F (0 to 50°C)
Over Input Display	Indication of " - - - "
Power Supply	9V battery (not included)
Power Consumption	Approx. 6.2 mA DC
Weight	5.6 oz (160g)
Dimension	6.14" x 2.36" x 1.29" 156 x 60 x 33 mm

### Measurement Specifications

MEASUREMENT		RANGE	RESOLUTION	ACCURACY
Air Velocity	ft/min	80 to 5,910 ft/min	1 ft/min	≤ 20 m/s : ± 3% F.S. > 20 m/s : ± 4% F.S.
	m/s	0.4 to 30.0 m/s	0.1 m/s	
	km/h	1.4 to 108.0 km/h	0.1 km/h	
	MPH	0.9 to 67.0 mile/h	0.1 MPH	
	knots	0.8 to 58.3 knots	0.1 knots	
Temperature (thermistor)	° F	32° to 122 °F	0.1 °F	± 2.5 °F
	° C	0° to 50 °C	0.1 °C	± 1.2 °C
Air Flow	CFM	1,908,400 CFM	0.001 to 100	0.001 to 1
	(cube feet/min)	CFM		
	CMM (cube meter/min)	CMM	54,000 CMM	
Humidity	% RH	10 to 95 % RH	0.1 % RH	< 70% RH : > 70% RH : : ± (4%rdg + 1.2%RH)
		10 to 95% RH		
		± 4% RH		
Light	Lux	0 to 2,200 Lux	1 Lux	± 5% rdg ± 8 dgt
		1,800 to 20,000 Lux	10 Lux	
		0 to 20,000 Lux		
		0 to 2,000 Fc		
Temperature (Type K)		-148 to 2,372 °F		+ (1% rdg + 2°F)
		-100 to 1,300 °C		+ (1% rdg + 1°C)
*auto range	Ft-cd	0 to 204.0 Fc	1 Ft-cd	
		170 to 2,000 Fc	1 Ft-cd	



### Accessories

#### STANDARD

SCASE Soft Carrying Case

#### OPTIONAL

TPFDA FDA Approved Thermocouple Probe

TPP Thermocouple Piercing Probe

TPS Thermocouple Surface Probe

#### MEASUREMENT AREA SET

CFM 0.01 to 322.92 feet square

CMM 0.001 to 30.000 meter square

## RPT61 Pressure Temperature Chart Master

For instant information, the PT Chart Master eliminates the need for traditional pressure/temperature charts. Accurate and easy to use, the RPT61 provides pressure and temperature correlation for 66 different refrigerants.

### Features/Benefits

- Choose Pressure in PSI, BAR or Mpa
- Choose Temperature in °F or °C.
- 66 Refrigerant Tables
- Large LCD
- Auto off (after 5 min.)
- Pocket size
- Battery Included Power: 3 V (CR2032)
- Soft carrying case included
- 1 year Warranty

### Applications

- For calculating Superheat or Sub-Cooling

### Specifications

PRESSURE UNITS	RANGE
PSI	5.1 to 462.5
BAR	0.35 to 31.88
MPa	0.035 to 3.188
TEMPERATURE UNITS	
Fahrenheit	-40°F to 155°F
Celsius	-40°C to 68°C





## IAQ Series Indoor Air Quality Instruments

SUPCO's IAQ Series measure Carbon Dioxide (CO<sub>2</sub>), Temperature and Humidity with Dew Point and Wet Bulb. Ideal for air quality diagnosis, they can be useful in identifying sick building syndrome due to high levels of CO<sub>2</sub>. Choose from a hand held meter or a wall mounted/ desktop monitor.



IAQ50

### Common Features/ Benefits

- Non-Dispersive Infrared (NDIR) Sensor
- Visible/ Audible (80db) CO<sub>2</sub> Alarm
- Large Triple Function LCD Display
- Min./ Max., Average Recall
- Alarm Output Relay
- Long Time Drift Compensation
- Non-Dispersive Infrared (NDIR) Sensor
- 12 VDC Power Adapter (120 VAC Supplied)
- TWA (Time-Weighted Average) 8 HRS
- STEL (Short-term exposure limit) 15 Minutes

### Applications

- Residential
- Offices
- Restaurants
- Warehouses
- Garages
- Green Houses



IAQ55

### IAQ50 Wall Mounted Indoor Air Quality Monitor

...for continuous monitoring of important IAQ parameters.

- Desktop or Wall Mounting
- Alarm Output Relay
- 12 V Power Adapter (included)

### IAQ55 Handheld Indoor Air Quality Monitor

...for pinpointing IAQ problem areas

- Portable
- Backlight LCD Display Function
- Auto Shut-off

### Specifications

CO2	IAQ55	IAQ50
Range	0-2000ppm 2001-9999 (out of scale)	
Resolution	1ppm	
Accuracy	±75ppm±5%rdg (0-2000 ppm) Not specified for out of scale	±50ppm±5%rdg (0-2000 ppm) Not specified for out of scale
Pressure Dependence	+ 1.6% reading per kPa deviation from normal pressure, 100kPa	

### TEMPERATURE

Range	14 to 140°F (-10.0 to 60.0°C)
Resolution	0.1°F (0.1°C)
Accuracy	±0.9°F (± 0.6°C)

### HUMIDITY

Range	0.0 to 99% Non-Condensing
Resolution	0.1%
Accuracy	+ -3% (10 to 90%) + -5% (others)

### GENERAL

Warm Up	30 seconds
Operating	+32 to 122°F (0 to 50°C) 0-95% RH Non-Condensing
Storage	-4 to 140°F (-20 to 60°C) 0-99% RH Non-Condensing
Power	4 AA batteries (Included)   12V adapter (Included)
Battery Life	24 hours (Alkaline)

## CO1000 Carbon Monoxide Meter

Measure CO quickly and easily in working and living environments.



### Features/Benefits

- Backlit LCD
- Automatic calibration
- Max Hold and Data Hold
- Auto Power Off
- Audible Alarm
- From 35 PPM to 200 PPM, the beeper sounds periodically
- Above 200 PPM, the beeper sounds continuously

### Applications

- Check dangerous CO levels
- Identify malfunctioning equipment

### Specifications

Measurement Range	0 to 1000 PPM
Measurement Resolution	1 PPM
Accuracy	5% or ±10 PPM (0-100 PPM) 10% ± 10 PPM (>100PPM)
Warm Up Period	< 2 Seconds
Operating Temperature	32°F to 122°F (0°C to 50°C)
Storage Temperature	-22°F to 140°F (-30° to 60°C)
Operating Humidity	0-99% Relative Humidity (non-condensing)
Battery	9V (included)
Auto Power Off	After 15 minutes of inactivity
Sensor Type	Stabilized electrochemical Gas-specific (CO)
Typical Sensor Life	3 years

## CL50 Combustible Gas Leak Detector

Detect Combustible Gas quickly and easily. With Audible and Visual alarms, the inexpensive, pocket-size CL50 Provides accurate and instantaneous response in a combustible environment.



### Features/Benefits

- Detects Combustible Gases and Static Electricity
- Audible and Visual Alarms
  - Green LED Indicates Power is On
  - Red LED and Buzzer Indicates Presence of Combustible Gas
  - Yellow LED and Buzzer Indicates Static Electricity is Detected
- Pocket Size • Easy to Use • 1 Year Warranty

### SPECIFICATIONS

Operating Temperature	14°F to 122°F (-10°C to 50°C)
Operating Humidity	95% RH or Lower (non-condensing)
Natural Gas Sensitivity	500 ppm min, 6500 ppm max
Propane Sensitivity	1000 ppm min, 6500 ppm max
Power Consumption	DC 200mA
Battery	1.5V X 2(AAA Size)
Duration of Use	Approximately 4 hours continuously
Dimensions	6.5 in. X 0.08 in. (164 mm X 21mm)
Weight	.88 oz. (25g)

# Specialty Meters

## DDM55 Dual Digital Manometer

Isolate difficult pressure problems in natural gas and propane systems with the DDM55 dual input Digital Manometer. Providing a differential measurement, the DDM55 accurately tests for leaks in low-pressure gas systems and more.



### Features/Benefits

- Dual input
- Range: -55.0 to +55.0 Inches Water Column
- Resolution to 0.01"
- Provides Differential Measurements
- 11 Units of Measure
- Data Hold
- LCD Display w/ Backlight
- Auto Power Off
- 9 V Battery Included
- Soft Carrying Case Included

### Applications

- Confirm Pressure Switch Operation
- Regulator Adjustments
- Set Delivery Pressures
- Leakage Tests

### Specifications

FUNCTION	RANGE	RESOLUTION
InH <sup>2</sup> O	+/-55.40	0.01
psi	+/-2.000	0.001
Mbar	+/-137.8	0.1
kPa	+/-137.9	0.01
inHg	+/-0.407	0.001
mmHg	+/-103.4	0.1
ozin <sup>2</sup>	32.00	0.01
FtH <sup>2</sup> O	4.612	0.001
cmH <sup>2</sup> O	140.6	0.1
Kgcm <sup>2</sup> .140	0.001	
Bar	0.137	0.001

## MTM1028 Moisture Test Meter

Moisture is the #1 reason for mold problems. The MTM1028 provides details to moisture levels in virtually all materials. Use the piercing probes with 3 foot cable to test for moisture anywhere.



### Features/Benefits

- Indicates 10% to 28% moisture levels
- Dual scale for maximum resolution
- Dual piercing probes
- 3 foot coiled cable

### Applications

- Pinpoint areas ideal for mold growth
- Locate water leaks and check for wet rot
- Find out if potentially damaging excess moisture is present
- Detect moisture level in wood, concrete, plaster, carpet and more.



## WA100 Water Alarm w/Remote Sensor

Protect property and valuable possessions. With its 85dB alarm, the WA100 will alert you immediately of the presence of water.



### Features/Benefits

- 85 dB alarm sounds for up to 3 days.
- Remote sensor has 6 foot wire
- Dual position sensor
- Test button
- Wall mountable alarm

### Applications

- Warns of leaks and overflows
- Alerts user when desired water level is reached (i.e. pools)
- Kitchen, laundry, furnace, computer room, pools, aquariums, more...

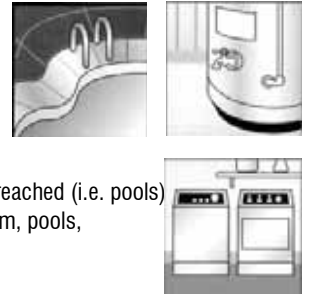

## DHS55 Digital Handheld Scale

This compact handheld scale provides quick measurements for your refrigeration applications.



### Features/Benefits

- 55 lbs max scale
- 2% accuracy
- One button operation
- Lbs/Kgs switchable
- 9 V battery included

### Specialty Instrument Selection Guide

- Measurement/Function - Weight
- Range - 0 to 55 lbs

## CTC3 Cap Tube Computer

Calculate the flow rate of a defective cap tube and duplicate that flow rate with cap tubes that have a different I.D.



### Features/Benefits

- Computes inside diameter, length, refrigerant, horse power, application and flow rate
- Shows temperature/pressure charts for 12 refrigerants
- Compact, light weight & easy to use!
- Converts Cap Tubing used with refrigerants R12, 134A, R22, and R502

### Specialty Instrument Selection Guide

- Measurement/Function - Cap Tube parameters
- Range - Various

**Note:** See Cap Tubing Section pages 29-31 for a complete listing of Cap Tubing Replacements used with alternative refrigerants.

# Multimeter & Current Probes



## DM10T Economy Digital Multimeter with Temperature

The DM10T Digital Multimeter provides an economical solution to your everyday electrical and temperature measurement needs.

### Features/Benefits

- 1000 Volts DC
- Continuity
- 2M W Resistance
- 10 Amps DC
- 750 Volts AC
- Temperature

## Current Probes



## CPH100 HVAC Current Probe

### Features/Benefits

- 400 Amps AC
- DC  $\mu$ Amps
- AC/DC Volts
- Resistance
- Capacitance
- Temperature
- Frequency
- Continuity
- Auto Shut off
- 1 year Warranty
- Includes Test Leads



### Applications

- HVAC Equipment Consumption
- Flame Safeguard circuits (CPH100)
- Branch Circuit Current
- AC Line and Control Voltages
- Continuity Check
- Temperature Testing
- Capacitor Testing



## CP070 Open Jaw Multi Probe

### Features/Benefits

- Simultaneous measurements: 200 Amps AC and one of the following:
  - AC or DC Volts
  - Resistance
  - Capacitance
  - Frequency
- Two LCD displays
- 3 year Warranty

### Digital Multimeters and Current Probe Specifications

	DM10T	CP070	CPH100
Volts AC	750	600	600
Volts AC Best Resolution	1 V	1mV	0.1mV
Volts DC	1000	600	600
Volts DC Best Resolution	0.1 mV	0.1mV	0.1mV
Amps AC	10	200A	400A
Amps AC Best Resolution	0.1mA	100mA	0.1A
Frequency (Hz)		9.999MHz	150.0KHz
Frequency Best Resolution		0.001Hz	0.001Hz
Base Accuracy (DC Volts) (AC Amps)	$\pm 0.5\% \pm 2$ dgts	$\pm 1.2\% \pm 2$ dgts $\pm 3.0\% \pm 3$ dgts	$\pm (1.5\% + 3$ dgts) $\pm (2.0\% + 3$ dgts)
Resistance max. (Ohms)	2 M	40M	40M
Continuity	Yes	Yes	Yes
Capacitance		200 $\mu$ F	100.0 $\mu$ F
Best Resolution		1pF	0.01nF
Temperature	-4 °F to 2498° F (-20° C to 1370 °C)		-50°F to 2372°F -5°C to 1300°C
Temperature Accuracy	$\pm 3 \pm 2$ digits		$\pm (3\% + 5$ digits)
Display (Counts)	2,000	2,000	4,000
Data Hold		Yes	Yes
Sleep Mode			Auto Shut Off
Operating Temperature	32° F to 74° F (0°C to 23°C)	14°F to 122°F (-10°C to 50°C)	14°F to 122°F (-10°C to 50°C)
Storage Temp. Temperature		-22°F to 140°F (-30°C to 60°C)	-22°F to 140°F (-30°C to 60°C)
Relative Humidity	0% to 75% RH	0% to 90% RH	0% to 90% RH
Fuse Protection	mA: 0.2A/ 250V		
Power	9 V Battery (included)	2 AA Batteries (included)	2 1.5V AAA Batteries (included)
Size	5.5"L x 3"W x 1.5"D (140mm x 76mm x 36mm)	8.5"L x 2.0"W x 1.7"D (216mm x 51mm x 43mm)	7.9"L X 2.0W" X 1.4"D (200mm X 50mm X 35mm)
Weight	8 oz (227 g)	16 Oz. (454g)	7.1oz (200g)
Warranty	1 Year		1 Year

## Optional Accessories



## TLA Test Leads

- 1000V AC or DC max
- 10 Amps max
- Includes screw-on alligator clips



## TPFDA FDA Approved Temperature Probe



## SCDM/SCCP Soft Deluxe Cases

- Rugged Cordura Case
- Zippered Case

### Soft Case Dimensions

PART NO.	DIMENSIONS
SCDM	6 1/4" Wide 9 3/4" Long 2 1/2" Deep
SCCP	5 1/4" Wide 7 1/4" Long 2 1/2" Deep

# Data Loggers



## DVTH Data View Data Logger Temperature Humidity Logger with Display



Record and INSTANTLY display trends for temperature, humidity and dew point with the DVTH. Monitor real time measurements for instant environmental conditions. When you're ready, download over 40,000 data points to your PC for further analysis. Data logging has never been this visual!

### Features/ Benefits

- Text Display: Real time temperature, humidity and dew point. Logging summary, sample rate, memory used and memory left
- Graph Display: Shows measurement trends graphically, with scrolling feature.
- Visual over and under alarm indicators for temperature and humidity
- USB connection (cable included)
- Compatible with Windows™ 98SE, ME, 2000, XP, Vista and above
- Calibration through software

### Applications:

- Refrigerators/Freezers
- Commercial Refrigeration Systems
- Wine Storage
- Greenhouses
- Florists
- Museums
- Medical Storage Facilities
- Laboratories

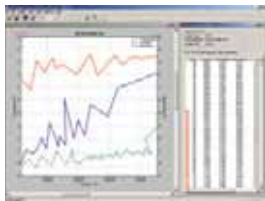

### Logger Specifications

Text Display	Displays real time temperature, humidity and dew point. Displays logging summary, sample rate, memory used and memory left.
Graph Display	Shows measurement trends graphically. Graph can be scrolled through the entire logged data.
Sample Point Capacity	43,344 points for temperature only. 21,672 points for temperature, humidity and dew point.
Alarms	Visual over and under alarm indicator for temperature and humidity. Dew point alarms are not available
Calibration	User single point offset calibration is available through software for both temperature and humidity. Calibration is password protected.
Operating Temperature	15°F to 150°F (-10°C to 65°C)
Storage Temperature	-5°F to 160°F (-20°C to 70°C)
Time Accuracy	±100ppm @75°F
Relative Humidity Range	0% to 99%RH, non condensing.
Relative Humidity Accuracy	± 2%RH, from 10% to 90% RH
Relative Humidity Resolution	0.01%RH
Temperature Accuracy	±1°F (0.5°C)
Temperature Resolution	0.01°F or 0.01°C
Dimensions	4" x 3.05" x 1.5" (10.2cm x 7.7cm x 3.8cm)
Weight	7.0 oz (200g)
Power Source	3 AA Alkaline or Lithium batteries
Battery Life (average use)	2 Years

### Software Specifications

PC Interface	USB port. USB cable is included
Sampling Interval	User selectable from 1 second to 18 hours, in 1 second increments.
Data Security	Unique factory set logger ID. Recording session counter. Password protected calibration.
Operating System Compatibility	Windows 98SE, Windows ME, Windows 2000, Windows XP, Vista and above. <u>Not compatible with Windows NT or Windows 95.</u>
Minimum System Requirements	5MB of free disk space, 800 x 600 screen resolution, 1 free USB port.
Recording Start	On button press, immediate after setup, or at a user specified date and time.
Recording Mode	Stop on memory full, or continuous recording with memory rollover
Real Time Status	Visual indication through the status LED. Software real time status.
User Calibration	Password protected calibration for each channel.
User Information	Up to 30 characters
Logger Channels	User selectable. Disabling channels increases the storage capacity of the other channels.
Units	US and Metric
Data Format	Exportable to text or Excel files.

# Data Loggers

## Super Vision Series - 5 in 1 Temperature and Humidity Printer Logger

The VLT Loggers are feature packed, strip recorder/alarm devices. Models with 1 to 4 channels to monitor temperature, humidity or switches with programmability for each. The Large digital display, PC Interface without additional software, 4 modes of printing and remote alarm dialer contacts give these devices features found on products costing much more.



### VLT Temperature Data Logger Recorder

#### Features/Benefits

- Monitoring, logging, alarms and printing in real time
- Up to 4 input channels of temperature, humidity and switches
- Reading intervals from 1 to 120 minutes, 1 min. increments
- Over and under alarms plus delay setting for each channel
- Operating and setting by means of 6 function keys
- Printed help and instruction messages on request during unit setup
- 1 channel printing in auto scale graph mode, including alarms
- 1 to 4 channel printing full reports in 3 text modes, including alarms
- On line display/minimum or maximum on request
- Exporting real time data thru RS-232 PC port- no software needed
- °F or °C degrees, date format: dd/mm/yy or mm/dd/yy
- Battery back up
- Low battery, chart end and probe error indicators and alarms buzzer
- Remote alarm output via relay contacts of 0.5A, 115V
- Remote probes 33' (10 meters) cable length, extendible up to 100'
- Data and settings retained after power failure
- Base unit operating humidity: 0 to 95% RH, non-condensing



### Specification

Base Unit	
Operating Temperature Range	32°F to +140°F (-0°C to +60°C) with alkaline battery
Operating Humidity	0 to 95% RH, non-condensing
Storage Temperature	-40°F to +150°F (-40°C to +65°C) with lithium battery
Battery Back-up	9 volt
Clock battery	3.6 volt lithium
Dimensions	8.2" X 5.3" X 2.7" (208.6 mm X 135 mm X 69 mm)
Weight	2.6 lbs. (1.8 kg)

PART NO.	INPUT	MEASURING OPTIONS	INCLUDED PROBES 33'	SAMPLE CAPACITY
<b>VLT4-12</b>	12 VAC/DC	Any combination of temperature and switches up to 4 channels	1 "VLT PROBE" (for temperature)	16,200 points of temperature and switches (4 probes)
<b>VLT4-115</b>	115 VAC			
<b>VLT4-230</b>	220 VAC			
<b>VLTH-12</b>	12 VAC/DC	Temp., humidity and switch or 2 channels of temp. and humidity	1 "VLTH PROBE" (temp./humidity)	16,200 points temperature, and humidity (4 channel)
<b>VLTH-115</b>	115 VAC			
<b>VLTH-230</b>	220 VAC			

### Accessories

<b>VLPAPER</b>	2" Thermal chart roll 131'
<b>VLWPCASE</b>	Water proof case + lock
<b>VLSK</b>	Remote alarm silencer
<b>CABLE10H</b>	Sensor extension 10'
<b>CABLE33H</b>	Sensor extension 33'
<b>VPR</b>	Power reducer 24 to 12V
<b>ADTA</b>	Auto phone dialer
<b>VLCEL</b>	Cellular adaptor to internet

PROBE MODEL	WORKING RANGE	RESOLUTION	ACCURACY	REPEATABILITY	RESPONSE
<b>VLT PROBE</b>	-40°/130°C	0.1°C	±0, 3°C	±0.1°C	5-30
Temperature	-40°/266°F	0.2°F	±0.6°F	±0.2°F	Sec.
<b>VLTH PROBE</b>	-40°/85°C	0.1°C	±0, 5°C	±0.1°C	5-30
Temperature	-40°/185°F	0.1°F	±1, 0°F	±0.2°F	Sec.
and Humidity	10.0/89.9% RH	0.1% RH	±2% RH	±0.1% RH	6-10
	0.1-9.9/90-100%	0.1% RH	±4% RH	±0.5% RH	Sec.
<b>VLS CABLE</b>	Recognized dry contacts - for On/Off indication switch				1 Sec.

# Data Loggers

## LOGiT Series

Select the right Logger for your application...

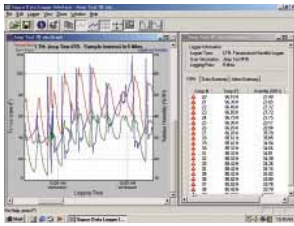

### Features/Benefits

- Stores over 10,000 measurement points
- 1 second to 18 hour sample rate; 1 second increments
- Custom user identification (30 characters)
- Real Time data monitoring
- Over/Under Alarm threshold settings
- Visual alarm indication
- User selectable Recording Start (Specify date & time, immediate after setup or on door close)
- Tamper proof
- 20 month battery life (at 1 minute sample rate)
- Data rollover option
- Unique logger ID
- One PC Software operates with all loggers (LLS not included)
- Graphic or text data
- Zoom capability
- USB interface optional (USBS)
- 1 year warranty

### Application Note:

The LOGiT Series Data Loggers have one common PC Software and Interface Kit (LLS or LLSU).

Choose one or more LOGiT Data Loggers and the appropriate PC Software Interface Kit to complete your Data Logger selection. See page 87 for details.

### For Temperature and Temperature/Humidity Sensitive Applications:

- Refrigerators/Freezers
- Commercial Refrigeration Systems
- Medical Storage Facilities
- Laboratories
- Greenhouses
- Florists
- Museums

### LT2 Temperature Logger (Internal & External)

- One Internal and One External Temperature Measurement, simultaneously

### LTT Dual Temperature Logger

- 2 Independent External Temperature Measurements & Temperature Differential
- 2 DLTP6 Sensors (Included)

### LTC Thermocouple Temperature Logger

- One Internal and One External (J, K, E, T, R, S Thermocouples) Temperature Measurement

### LTH Temperature and Humidity Logger

- Integral Temperature, Humidity and Dew Point Measurements

### LPT Pressure and Temperature Logger

- External Pressure and Temperature Measurements

### For Pressure and Temperature Sensitive Applications:

- Compressor Run Cycles
- Testing New Installations
- Pneumatic air lines
- Tracking Intermittent Problems
- Superheat Measurements

### LCV Current and Voltage Logger

- External Current Probe and Voltage Measurements

### For Simultaneous Single Phase Current and Voltage Monitoring:

- Compressor and Fan Run Cycles
- Verification of Power Conditions
- Use three LCV's for Three Phase Applications

### L420 4 – 20 ma Logger

- Connection for 4 – 20 ma loop measurements

### For Monitoring 4 – 20 ma Process control loops in:

- Manufacturing
- Package Handling
- Automated Test Systems

# Data Loggers

## LT2, LTH, LTC & LTT Data Logger Specifications

	LT2	LTH	LTC	LTT
Sample Point Capacity	21,500 points (Single channel) 10,750 points and differential (Dual channel)	21,500 for temperature only 10,750 points for Temperature, Humidity and Dew Point	10,750 points for external and internal temperature	21,500 temperature points (1 probe) 10,750 temperature points and differential (2 probes)
Sampling Rate	1 second to 18 hours	1 second to 18 hours	1 second to 18 hours	1 second to 18 hours
Alarms	Over and under alarms for each probe.	Over and under alarms for temperature & humidity.	Over and under alarms for each probe	Over and under alarms for each probe.
Temperature Range (Internal Sensor)	32°F to 140°F (0°C to 60°C) w/ Alkaline Battery -40°F to 150°F (-40°C to 65°C) w/ Lithium Battery	32°F to 140°F (0°C to 60°C) w/ Alkaline Battery -40°F to 150°F (-40°C to 65°C) w/ Lithium Battery	32°F to 140°F (0°C to 60°C) w/ Alkaline Battery -40°F to 150°F (-40°C to 65°C) w/ Lithium Battery	
Temperature Range (External Sensor)	-40°F to 150°F (-40°C to 65°C)		Depends on thermocouple J,K,E,T,R,S	-50°F to 300°F (-46°C to 150°C) 2DLTP6
Accuracy	±1.0°F (0.5°C)	±2°F (1°C)	Depends on thermocouple	±2°F (1°C)
Resolution	0.1°F (0.05°C)	0.1°F (0.05°C)	0.1°F (0.05°C)	0.1°F (0.05°C)
Time Accuracy	±100ppm @75°F	±100ppm @75°F	±100ppm @75°F	±100ppm @75°F
Relative Humidity Range		0% to 99.9% RH, Non-condensing.		0% to 95% RH, non-condensing
Relative Humidity Accuracy		±2% full scale, from 0% to 95% RH for temperatures between 32°F and 140°F (0°C to 60°C)		
Relative Humidity Resolution		0.1% RH		
Temperature using Alkaline Battery	32°F to 140°F (0°C to 60°C)	32°F to 140°F (0°C to 60°C)	32°F to 140°F (0°C to 60°C)	32°F to 140°F (0°C to 60°C)
Temperature using Lithium Battery	-40°F to 150°F (-40°C to 65°C)	-40°F to 150°F (-40°C to 65°C)	-40°F to 150°F (-40°C to 65°C)	-40°F to 150°F (-40°C to 65°C)
Operating Range Humidity	0% to 95% RH, Non-condensing	0% to 99.9% RH, Non-condensing		
Storage Temperature	-40°F to 170°F (-40°C to 77°C)	-40°F to 170°F (-40°C to 77°C)	-40°F to 170°F (-40°C to 77°C)	-40°F to 170°F (-40°C to 77°C)
Calibration	Single point offset calibration available through software.	Single point offset calibration available through software. Humidity is factory calibrated.	Single point offset calibration available through software.	Single point offset calibration available through software.
Dimensions	3" x 2.5" x 1.1" (7.6cm x 6.4cm x 2.8cm)	3" x 2.5" x 1.1" (7.6cm x 6.4cm x 2.8cm)	3" x 2.5" x 1.1" (7.6cm x 6.4cm x 2.8cm)	3" x 2.5" x 1.1" (7.6cm x 6.4cm x 2.8cm)
Weight	2.5 oz (71g)	2.5 oz (71g)	2.5 oz (71g)	2.5 oz (71g)
Power Source	9V Alkaline or Lithium battery (not included)	9V Alkaline or Lithium battery (not included)	9V Alkaline or Lithium battery (not included)	9V Alkaline or Lithium battery (not included)
Battery Life (average use)	18 Months using Alkaline Battery 36 Months using Lithium Battery	20 Months using Alkaline Battery 40 Months using Lithium Battery	20 Months using Alkaline Battery 40 Months using Lithium Battery	20 Months using Alkaline Battery 40 Months using Lithium Battery

\*Note: Logger needs optional **LLS** or **LLSU** Software package to program data logger and download data for analysis. It is not included with any LOGiT data logger.

\*Note: The SUPCO LOGiT and DL Series Loggers are NOT compatible.

# Data Loggers

## LPT, LCV & L420 Data Logger Specifications

	LPT	LCV	L420
Sample Point Capacity	10,750 points for Pressure & Temperature 21,500 points for Pressure OR Temperature	10,750 points for Current & Voltage 21,500 points for Current OR Voltage	21,500 points
Sampling Rate	1 second to 18 hours	1 second to 18 hours	1 second to 18 hours
Alarms	Over and under alarms for Pressure & Temperature	Over and under alarms for current and voltage	Over and under alarm
Temperature Range (External Sensor)	-40°F to 150°F (-40°C to 65°C)		
Accuracy	±1°F (0.5°C)		
Resolution	0.1°F (0.05°C)		
Time Accuracy	±100ppm @75°F	±100ppm @75°F	±100ppm @75°F
Pressure Range	0-500 psi		
Pressure Sensor Temperature Range	-4°F to 185°F -20°C to 85°C		
Compensated Temperature Range	32°F to 130°F 0°C to 55°C		
Pressure Accuracy	±3 psi		
Pressure Resolution	0.15 psi		
Pressure Connection	1/4" MPT Pressure Sensor Connection		
Input Current Range		0-300 Amps	0-40 ma
Current Accuracy		±5%	±0.05 ma
Current Resolution		0.1 Amp AC	0.01 ma
Voltage Range		0-500 Volts AC	
Voltage Accuracy		±1 VAC	
Voltage Resolution		0.1 VAC	
Temperature using Alkaline Battery	32°F to 130°F (0°C to 54°C)	32°F to 130°F (0°C to 54°C)	32°F to 140°F (0°C to 60°C)
Temperature using Lithium Battery	-40°F to 150°F (-40°C to 65°C)	-40°F to 150°F (-40°C to 65°C)	-40°F to 150°F (-40°C to 65°C)
Operating Range Humidity	Non-condensing	0% to 95% RH, Non-condensing	0% to 95% RH, 0% to 95%, Non-condensing
Storage Temperature	-40°F to 170°F (-40°C to 77°C)	-40°F to 170°F (-40°C to 77°C)	-40°F to 170°F (-40°C to 77°C)
Calibration	Single point offset calibration available through software. Pressure is factory calibrated.	Single point offset calibration available through software. Current and Voltage are factory calibrated.	Single point offset calibration available through software.
Dimensions	3" x 2.5" x 1.1" (7.6cm x 6.4cm x 2.8cm)	3" x 2.5" x 1.1" (7.6cm x 6.4cm x 2.8cm)	3" x 2.5" x 1.1" (7.6cm x 6.4cm x 2.8cm)
Weight	2.5 oz (71g)	2.5 oz (71g)	2.5 oz (71g)
Power Source	9V Alkaline or Lithium battery (not included)	9V Alkaline or Lithium battery (not included)	9V Alkaline or Lithium battery (not included)

# Data Loggers



## LLS

### LOGiT PC Software and Interface for Serial Connection

- PC Software on CD ROM
- LINT Interface
- Cable for LOGiTs to Serial Port (CABLE6)



## LLSU

### LOGiT PC Software and Interface for USB Connection

- PC Software on CD ROM
- LINTU Interface
- Cable for LOGiTs to USB Port (19449)

### Benefits/Specifications

- Compatible with Windows 95 and above
- Graphic and Text Data
- 3 Memory modes: Stop on full, record continuously, or memory rollover
- Real time monitoring
- Password protected calibration of each channel
- Data exportable to Text or Excel
- Maximum Serial Interface 50 feet.
- Minimum System Requirements: 8MB RAM, 2MB Disk Space, 800 x 600 Resolution, COM port or USB port

### LOGiT Accessories

Standard Accessories	LT2	LTH	LTC	LTT	LPT	LCV	L420
<b>14265-001</b> 15' Remote Temperature Sensor	*				*		
<b>DLTP6</b> 4" Stainless Steel 6' Temperature Sensor				(2)			
<b>TPFDA</b> K-type Thermocouple with 4' FDA Approved Insulation			*				
<b>12867</b> 300 A Current Probe†						*	

Optional Accessories	LT2	LTH	LTC	LTT	LPT	LCV	L420
<b>LITH9B</b> Lithium Battery	*	*		*	*	*	*
<b>USBS</b> USB to Serial Interface	*	*		*	*	*	*
<b>LLS</b> LOGiT PC Software & Interface	*	*	*	*	*	*	*
<b>LLSU</b> LOGiT PC Software & Interface	*	*	*	*	*	*	*
<b>SW25</b> 25' Temperature Sensor Extension Wire	*				*		
<b>SW50</b> 50' Temperature Sensor Extension Wire	*				*		
<b>SW75</b> 75' Temperature Sensor Extension Wire	*				*		
<b>SW100</b> 100' Temperature Sensor Extension Wire	*				*		
<b>CABLE10T</b> 10' Sensor Extension Wire					*		
<b>CABLE10H</b> 10' Sensor Extension Wire (Max 3)				*			

†Pressure probe must be factory calibrated with LPT logger

\*Current sensor must be factory calibrated with LCV logger

# Data Loggers

## SL Series Miniature Data Loggers

Choose from Temperature, Humidity and Dew Point, or Temperature only Data Logging in a miniature, self-contained device. The SL Series Data Loggers provide concise measurements for critical environmental conditions.



### For Temperature and/or Humidity Sensitive Applications:

- Refrigerators/Freezers
- Greenhouses
- Wine Storage
- Museums
- Commercial Refrigeration Systems
- Florists
- Medical Storage Facilities
- Laboratories

### SL300TH

Measures Temperature, Humidity and Dew Point simultaneously

#### Features/Benefits

- Windows™ 98SE, ME, 2000, XP, Vista and above compatible software (included)
- **Not compatible with Windows™ 95 or NT**
- PC, delayed start or push button recording control
- Temperature and Humidity alarm with visual indication on demand
- User selectable stop on memory full or memory rollover for continuous recording
- Real time monitoring
- View graph and text simultaneously
- Can calibrate through software
- Displays temperature in °F or °C
- USB Interface standard (Cable Included)



	SL300TH
Sample Point Capacity	43,344 for Temperature only. 21,672 for Temperature, Humidity and Dew Point
Sample Rate	1 second to 18 hours
Alarms	High and low temperature and humidity alarms w/visual indication on demand
Temperature Range	-40°F to 160°F (-40°C to 70°C)
Temperature Accuracy	±1°F (±0.5°C)
Temperature Resolution	0.1°F or 0.1°C
Relative Humidity Range	0% to 99% RH, non condensing
Relative Humidity Accuracy	±2% RH from 10% to 90% RH
Relative Humidity Resolution	0.01% RH
Calibration:	Single point offset calibration available through software For both Temperature and Humidity
Time Accuracy	±100 ppm @ 75°F
Dimensions	3" x 1.6" x 0.6" (7.6cm x 4.0cm x 1.5cm)
Weight	1.0 oz (28g)
Power Source	3 V (CR2032) Lithium battery (Included)
Battery Life	6 years typical



### SL300T

Measures Temperature only

#### Features/Benefits

- Windows™ 98SE, 2000, ME, XP and Vista and above compatible software (included)
- **Not compatible with Windows™ 95 or NT**
- PC, delayed start or push button recording control
- Temperature alarm with visual indication on demand
- User selectable stop on memory full or memory rollover for continuous recording
- Real time monitoring
- View graph & text simultaneously
- Can calibrate through software
- Displays temperature in °F or °C
- USB Interface Standard (Cable Included)



	SL300T
Sample Point Capacity	43,344 Temperature Samples
Sample Rate	1 second to 18 hours
Alarms	High and low Temperature alarms w/visual indication on demand
Temperature Range	-40°F to 185°F (-40°C to 85°C)
Temperature Accuracy	±1°F (±0.5°C)
Calibration	Single point offset calibration available through software for Temperature. Password protected
Time Accuracy	±100 ppm @ 75°F
Dimensions	3" x 1.6" x 0.6" (7.6cm x 4.0cm x 1.5cm)
Weight	1.0 oz (28g)
Power Source	3.0 V (CR2032) Lithium battery (Included)
Battery Life	Up to 6 years

SL300TH Graph

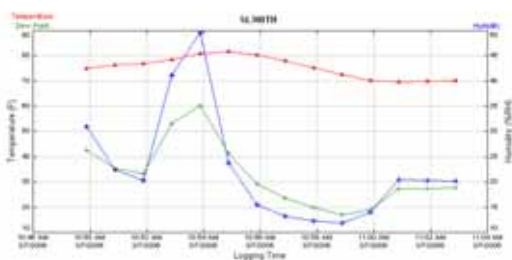

SL300T Graph

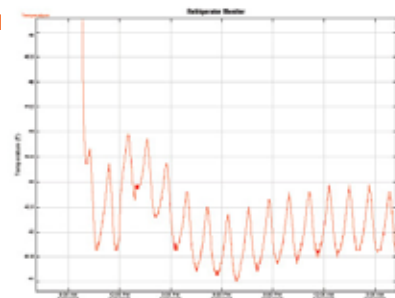



## CRTH2

### Temperature/Humidity/Dew Point Recorder

Selectable chart speeds from 1 1/2 hours to 31 days. Temperature ranges from -40°F to 130°F (-40°C to 55°C). With a 6-foot remote probe, 115V operation and battery back-up, the CRTH2 provides the ultimate in versatility and reliability.



#### Features/ Benefits

- Measures Temperature, Humidity and Dew Point
- Advanced, reliable micro-controller design
- Built – in “Last Setting” memory
- Two (2) line LCD display
- Easy-to-use membrane keypad
- All functions user selectable from front panel.
- °F / °C selectable
- Remote combination temperature/humidity probe with 6 foot cable
- Field calibration of probe
- Combination of 24 Speed and Temperature Ranges
- 6” circular chart
- Chart number displayed when Time & Temperature Ranges selected
- Single turn or continuous chart rotation
- Two (2) independent pens
- Alarm with delay for over and under temperature & humidity
- Audible and Visual Alarm indication
- Remote Alarm or telephone dialer connection (Optional Auto-dialer – ADTA)
- Standard 115 VAC operation
- Optional 12 VDC operation for auto or marine
- 48 hour battery back-up
- Low battery warning on display
- Durable polycarbonate case with full-view cover
- Free Standing or Wall mount
- Snap-on extra support legs
- Fold away carrying handle

#### CRTH2 Specifications

Temp Range/Accuracy	-40°F to 130°F ± 2°F (-40°C to 55°C ± 1°C)
RH Range/ Accuracy	0 to 95% (non condensing) at 32°F to 130°F ± 2% (0°C to 55°C) ambient
Dew Point Range	32°F to 130°F (0° to 55°C)
Chart Diameter	6 inches
Chart Rotation Mode	Continuous or Single turn
Chart Rotation Speed	1.5, 3, 6, 12 & 24 hrs, 7 & 31 days
Chart Speed Accuracy	± 1%
Charts	60 assorted included
Display	LCD 16 characters x 2 lines
Temperature Alarm Range	-20°F to 120°F (-30°C to 50°C)
Relative Humidity Alarm Range	0 to 100%
Alarm Delay	NO DELAY, 10 mins., 30 mins., 1 hr. or 2 hrs.
Remote Alarm Connection	NO, 48 VAC/DC, 0.1 A resistive load
Ambient Operating Temperature	32°F to 120°F (0°C to 49°C)
Primary Power	115 VAC, 50/60 Hz (230 VAC, 50/60 Hz optional)
Alternate Power	12 V vehicle operation (need optional adapter)
Battery backup	8 AA alkaline batteries (not included)
Battery Life	48 hrs. continuous
Dimensions	9 1/4" x 7 1/4" x 2 3/4"
Weight	4 lbs. 15 oz.

#### CRTH2 Accessories

PART NO.	DESCRIPTION
KTH	Temperature/ Humidity Probe
CABLE10H	Extension cable for KTH (2 max)
CRPENR	Red Recorder Pen
CRPENB	Blue Recorder Pen
CRT	115 VAC Power Adapter
CRT220	220 VAC Power Adapter
CRTH2	115V 50/60 Hz
CRTH2-220	220V 50/60 Hz
ADTA	Auto-Phone Dialer (Page 75)



#### Recorder Charts

TEMPERATURE RANGE 1	HUMIDITY RANGE 2	12 HR	24 HR	7 DAY	31 DAY
-20°F to 120°F	0-100% Humidity	E20120F12	E20120F24	E20120F7	E20120F31
-20°F to 50°F	0-100% Humidity	E2050F12	E2050F24	E2050F7	E2050F31
40°F to 110°F	0-100% Humidity	E40110F12	E40110F24	E40110F7	E40110F31
-30°C to 50°C	0-100% Humidity	E3050C12	E3050C24	E3050C7	E3050C31
-30°C to 10°C	0-100% Humidity	E3010C12	E3010C24	E3010C7	E3010C31
5°C to 45°C	0-100% Humidity	E545C12	E545C24	E545C7	E545C31

# Chart Recorders

## SR Series Strip Chart Recorders

The SR Series Strip Chart Recorders provide long length recordings with maximum detail. Choose the model that suits your application.



### Features/ Benefits:

- LCD alphanumeric display
- Adjustable chart speed (1/4 inch per hour to 2 inches per minute)
- Recording length: 2 hours to 40 days
- Over / Under Alarm with 100ma N.O. Relay and audible alarm
- Delay / No Delay Alarm
- Battery backup
- 220 V operation (optional)
- RS-232C port
- Use inches or mm charts
- Field calibrated with user adjustment
- Free standing or wall mount
- Chart length 20' (2 included)



### SRB - Temperature Recorder

#### Applications

- Refrigeration/Freezer, Laboratory and Environmental applications
- Measures and records temperature in air, gas, liquids, powders, solids and semi-solids

#### Features/Benefits

- Temperature Ranges: -40°F to 150°F (-40°C to 60°C)
- Remote readings from up to 100 ft. (CABLE 10T optional)
- Programmable speed and temperature ranges



### SRTH - Temperature/ Humidity Recorder

#### Applications

- Monitor critical temperature and humidity simultaneously

#### Features/Benefits

- Temperature Ranges: -40°F to 150°F (-40°C to 60°C)
- Humidity Range: 0 to 95% RH
- Programmable speed and temperature ranges



### SRJ - J-Type Thermocouple Temperature Recorder

#### Applications

- Broad temperature range
- Measures and records temperature in air, gas, liquids, powders, solids and semi-solids

#### Features/Benefits

- Temperature Ranges: -40°F to 1000°F (-40°C to 500°C)
- Remote readings from up to 2000 ft. (Use TCW25, TCW50, TCW75, TCW100)
- Programmable speed and temperature ranges



### SR4-20 4 to 20 mA and DC Voltage Recorder

#### Applications

- Verification of process control loops

#### Features/Benefits

- Current Range: 0 to 20 mA, 4 to 20 mA
- Voltage Range: 0 to 5 VDC, 0 to 100 mV
- Programmable speed and current and voltage ranges



### SRV - AC Voltage Recorder

#### Applications

- Line voltage
- Intermittent voltage problems

#### Features/Benefits

- Voltage Range: 0 to 500 VAC, single phase
- Programmable speed and voltage ranges
- Use 3 recorders for 3 phase applications



### SRC - AC Current Recorder

#### Applications

- Load distribution
- Compressor and fan run cycles

#### Features/Benefits

- Current Range: 0 to 300 Amps AC, single phase (current probe included)
- Programmable speed and current ranges
- Use 3 recorders for 3 phase applications

# Chart Recorders

## SR Series Common Specifications

Display	Alphanumeric LCD 16 Characters 2 Line	
Chart	Strip chart (20" x 4 3/4")	
Chart Speeds	1/4 inch/hour	1/2 cm/hour
	1 inch/hour	2 cm/hour
	2 inches/hour	4 cm/hour
	4 inches/hour	8 cm/hour
	8 inches/hour	16 cm/hour
	1/4 inch/minute	1/2 cm/minute
	1/2 inch/minute	1 cm/minute
	1 inch/minute	2 cm/minute
2 inches/minute	4 cm/minute	
Chart Speed Accuracy	±1%	
Alarm Delay Range	No Delay, 10 Min., 30 Min., 1 Hr., 90 Min. or 2 Hr.	
Remote Alarm Connection	N.O. 48 VAC/DC, 0.1 Amp Dry Contacts	

Operating ambient temperature range	32°F to 125°F (0° to 50°C)
Storage temperature	0° to 125°F (-18° to 50°C)
Primary power	115 VAC, 50/60 Hz Adapter (220-240 VAC, 50 Hz. optional)
Backup power	8 AA alkaline batteries (not supplied)
Alternative power	12 Volt vehicle operation with optional adapter
Power Consumption	3.5 Watts Max.
Mounting	Vertical or Horizontal, Free Standing or Wall Mounted
Dimensions	9.25" x 7.25" x 2" (235mm X 184mm X 51mm)
Weight	2.5 lb. (1.3 kg)

## SR Series Specifications

	SRB	SRJ	SRV	SRC	SR420	SRTH
Range	-40°F to 150°F (-40°C to 60°C)	-40° to 1000°F (-40° to 500°C)	0 to 500 VAC	0 to 300 Amps AC using supplied clamp-on probe	0-5.0 Volts DC 0-20ma DC 4-20ma DC	-40 to 150°F (0 to 60°C) 0 - 100% RH
Chart Ranges	-40°F to 60°F -40°C to 60°C 50°F to 150°F -30°C to 20°C 0°F to 100°F 0°C to 50°C	-40°F to 60°F -40°C to 60°C 0°F to 250°F -30°C to 20°C 50°F to 150°F 0°C to 50°C 0°F to 100°F 0°C to 100°C 0°F to 500°F 0°C to 500°C 0°F to 1000°F	0 to 50 VAC 0 to 100 VAC 50 to 150 VAC 0 to 250 VAC 0 to 500 VAC	0 to 10 AMP 0 to 50 AMP 0 to 100 AMP 50 to 150 AMP 0 to 250 AMP	0 to 5.00 Volts ±0.01 Volt 0 to 100 mV ±1 mV 0 to 20 mA ±0.1 mA 4 to 20 mA ±0.1mA	-40°F to 60°F -40°C to 60°C 50°F to 150°F -30°C to 20°C 0°F to 99°F 0°C to 50°C
Accuracy	±2°F (±1°C)	±2°F (±1°C)	±0.5 VAC	±5%	0 to 5.00 Volts ±0.01 Volt 0 to 100 mV ±1 mV 0 to 20 ma ±0.1 mA 4 to 20 ma ±0.1mA	±2°F (±1°C) ±2% (0 - 95% RH)
Probe	TP15 Temperature probe with 15' cable (cable extension is available)	6' High Temperature Thermocouple Probe	3' Voltage leads with Alligator clips	0-300 Amp AC Current Probe		KTH Temperature/ Humidity with 6' cable 95% RH (Non-Condensing)
Alarm Range	-40°F to 150°F (-40°C to 60°C)	-40°F to 1000°F (-40°C to 500°C)	0 to 500 VAC	0 to 300 AMP	0 to 20 ma (DC) 0 to 5 Volts (DC) 0 to 100 mV (DC)	40°F to 150°F (-40°F to 60°C) 0 to 100% RH

## SR Series Accessories

PART NO.	DESCRIPTION	SRB	SRJ	SRV	SRC	SR420	SRTH
ADTA	Automatic Dialer	*	*	*	*	*	*
CABLE10H	Extension cable for KTH						*
CABLE10T	10' cable	*					
CABLE15	15' cable for sensor probes						*
CABLE25	25' cable for sensor probes						*
CABLE6	6' cable for sensor probes						*
CRPEN	Black Pen	*	*	*	*	*	*
CRPENB	Blue Pen	*	*	*	*	*	*
CRPENR	Red Pen	*	*	*	*	*	*
CRT	Power Adapter	*	*	*	*	*	*
CRT220	Power Adapter	*	*	*	*	*	*
CRT220UK	Power Adapter	*	*	*	*	*	*
HTP5	6' high temperature thermocouple wire		*				
HTP5100	100' high temperature thermocouple wire		*				
HTP515	15' high temperature thermocouple wire		*				
HTP525	25' high temperature thermocouple wire		*				
HTP550	50' high temperature thermocouple wire		*				
KTH	Temperature Humidity Probe						*
SCR11	Strip Chart (American Scale) (20')	*	*	*	*	*	*
SCR12	Strip Chart (Metric Scale) (20')	*	*	*	*	*	*
SRVLA	Voltage leads with Alligator clips			*			
TCW100	Type J Thermocouple Wire - 100' wire only		*				
TCW25	Type J Thermocouple Wire - 25' wire only		*				
TCW50	Type J Thermocouple Wire - 50' wire only		*				
TCW75	Type J Thermocouple Wire - 75' wire only		*				
TP15	15' wire with 4" stainless steel sensor	*					

**Note:**  
Replacement current probe must be calibrated at factory.

# Chart Recorders

## Circular Chart Recorders

The CR87 Six(6) Inch Chart Recorder Series set the standard for reliable and rugged trend reporting. Choose the right model for your application.

### Common Features/Benefits

- Micro-controller design
- Large LED Display
- Front Panel controls
- Single or continuous chart rotation
- Choose from 120V or 220V models (see chart)
- Battery Backup
- 12 Volt operation. Allows use in vehicular or marine operations.
- Comes with 2 cartridge pens & 60 (6" dia.) assorted charts
- Convenient folding handle
- Fold-out support stand
- Free standing or wall mount



### NEW DESIGN



## CR87B - Temperature Recorder

### Applications

- Designed for Refrigerators/Freezers, Laboratory and Environmental Applications
- Measures and records temperature in air, gas, liquids, powders, solids, and semi-solids

### CR87B Series Recording Charts

TEMP. RANGE	6 Hrs.	24 Hrs.	7 Days	31 Days
-40°F to 30°F	CR87-4	CR87-1	CR87-7	CR87-19
-20°F to 50°F	CR87-5	CR87-2	CR87-8	CR87-20
50°F to 120°F	CR87-6	CR87-3	CR87-9	CR87-21
-40°C to 0°C	CR87-13	CR87-10	CR87-16	CR87-22
-30°C to 10°C	CR87-14	CR87-11	CR87-17	CR87-23
10°C to 50°C	CR87-15	CR87-12	CR87-18	CR87-24

### Features/Benefits

- Temperature range: -40°F to 120°F (-40°C to 50°C)
- Remote readings from up to 100 ft. (optional sensor wire p/n CABLE10T)
- Programmable speed and temperature ranges

PART NO.	TEMP. READING	TEMP. INVOLTAGE	OPERATING
CR87B	Fahrenheit	110-120V, 50/60 Hz	
CR87BC	Celsius	110-120V, 50/60 Hz	
CR87B220	Fahrenheit	220-240V, 50/60 Hz	
CR87B220C	Celsius	220-240V, 50/60 Hz	

### Extension Cable for CR87B Temperature Sensor

PART NO.	DESCRIPTION
CABLE10T	10' cable 100 ft. max

### Temperature Sensor for CR87B (31 Day Version)

PART NO.	DESCRIPTION
TP15	15' wire with 4" stainless steel sensor

## CR87J - Temperature Recorder

### Applications

- Designed for Refrigerators/Freezers, Laboratory and Environmental Applications
- Measures and records temperature in air, gas, powders, solids, and semi-solids

### Features/Benefits

- Type J Thermocouple
- Temperature range: -40°F to 120°F (-40°C to 50°C)
- Remote readings
- Programmable speed and temperature ranges
- Snap-on support legs
- Remote Readings from up to 200ft (see accessory table)

PART NO.	TEMP. READING	TEMP. INVOLTAGE	OPERATING
CR87J	Fahrenheit	110-120V, 50/60 Hz	
CR87JC	Celsius	110-120V, 50/60 Hz	
CR87J220	Fahrenheit	220-240V, 50/60 Hz	
CR87J220C	Celsius	220-240V, 50/60 Hz	

### CR87J Series Recording Charts

TEMP. RANGE	6 Hrs.	24 Hrs.	7 Days
-40°F to 30°F	CR87-4	CR87-1	CR87-7
-20°F to 50°F	CR87-5	CR87-2	CR87-8
50°F to 120°F	CR87-6	CR87-3	CR87-9
-40°C to 0°C	CR87-13	CR87-10	CR87-16
-30°C to 10°C	CR87-14	CR87-11	CR87-17
10°C to 50°C	CR87-15	CR87-12	CR87-18

### Temperature Sensor for CR87J

PART NO.	DESCRIPTION
CR15B	15' wire with 4" stainless steel sensor



Front Panel View

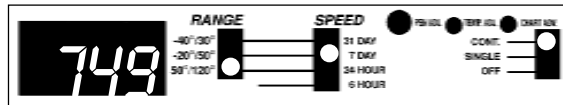

## CR87HT - High Temperature Recorder

### Applications

- Broad range of Temperature Applications
- Measures and records temperature in air, gas, liquids, powders, solids, and semi-solids

### Features/Benefits

- Temperature range: 0°F to 1000°F (0°C to 500°C)
- Remote readings from up to 2000 ft. (See accessory table)
- Programmable speed and temperature ranges
- Snap-on support legs

### High Temperature Sensor for CR87HT

PART NO.	DESCRIPTION
HTP5	6' high temperature thermocouple wire
HTP515	15' high temperature thermocouple wire
HTP525	25' high temperature thermocouple wire
HTP550	50' high temperature thermocouple wire
HTP5100	100' high temperature thermocouple wire

PART NO.	TEMP. READING	TEMP. VOLTAGE	OPERATING
CR87HT	Fahrenheit	110-120V, 50/60 Hz.	
CR87HT220C	Celsius	220-240V, 50/60 Hz.	
CR87HT220	Fahrenheit	220-240V, 50/60 Hz.	
CR87HTC	Celsius	110-120V, 50.60 Hz.	

### CR87HT Series Recording Charts

TEMP. RANGE	6 Hrs.	24 Hrs.	7 Days	31 Days
0°F to 250°F	CR1000-4	CR1000-1	CR1000-7	CR1000-19
0°F to 500°F	CR1000-5	CR1000-2	CR1000-8	CR1000-20
500° to 1000°F	CR1000-6	CR1000-3		
0°C to 120°C	CR1000-13	CR1000-10	CR1000-16	CR1000-22
0°C to 250°C	CR1000-14	CR1000-11	CR1000-17	CR1000-23
250° to 500°C	CR1000-15	CR1000-12	CR1000-18	CR1000-24



Front Panel View

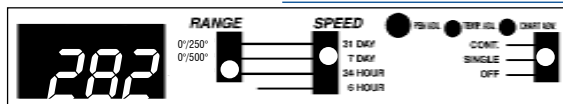

# Chart Recorders

## CR87P - Pressure Recorder



Front Panel View

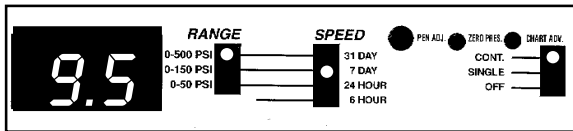

### Applications

- Run Cycles
- Pneumatic air lines
- Test new installations
- Track intermittent problems

### Features/Benefits

- Pressure Range 0 to 500 PSI (0 to 35 BAR)
- Stainless steel 17-4 Pressure sensor with port 1/4 NPT
- 2500 PSI burst pressure
- Rated for any gas or fluid compatible with 17-4 stainless steel
- Programmable speed and pressure ranges
- Snap-on support legs

PART NO. READING IN VOLTAGE	TEMP	OPERATING
CR87P	PSI	110-120V, 50/60Hz.
CR87P220	PSI	220-240V, 50/60Hz.
CR87PB	BAR	110-120V, 50/60 Hz.
CR87PB220	BAR	220-240V, 50/60 Hz.

### CR87P Series Recording Charts

RANGE	6 HRS.	24 HRS.	7DAYS	31DAYS
0 - 500 PSI	6H500PSI	24H500PSI	7D500PSI	31D500PSI
0 - 150 PSI	6H150PSI	24H150PSI	7D150PSI	31D150PSI
0 - 50 PSI	6H50PSI	24H50PSI	7D50PSI	31D50PSI

### CR87PB Series Recording Charts

PRESSURE RANGE	6 HRS.	24 HRS.	7 DAYS	31DAYS
0 - 35 BAR	6H35BAR	24H35BAR	7D35BAR	31D35BAR
0 - 10 BAR	6H10BAR	24H10BAR	7D10BAR	31D10BAR
0 - 3.5 BAR	6H3.5BAR	24H3.5BAR	7D3.5BAR	31D3.5BAR

### Pressure Sensor For CR87P, CR87PB

PART NO.	DESCRIPTION
CR87PA	Replacement pressure sensor and adapter

## CR87E - Event Recorder



Front Panel View

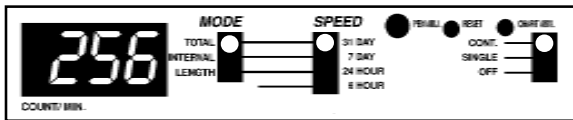

### Applications

- Time Studies
- Usage Tests
- Verification Tests

### Features/Benefits

- Complete with probes for Voltage, Sound and Light
- Displays length of event, time between events or total events
- Programmable speed and event information
- Snap-on support legs

PART NO.	OPERATING VOLTAGE
CR87E	110-120 VAC, 50/60 Hz
CR87E220	220-240 VAC, 50/60 Hz

### CR87E Series Recording Charts

6 Hrs.	24 Hrs.
EVENT-6H	EVENT-24H
7 Days	31 Days
EVENT-7D	EVENT-31D

### Event Sensors For CR87E

PART NO.	DESCRIPTION
KEV	Replacement voltage sensor with adapter
KEL	Replacement light sensor with adapter
KES	Replacement sound sensor with adapter

## CR87V - Voltage Recorder



Front Panel View

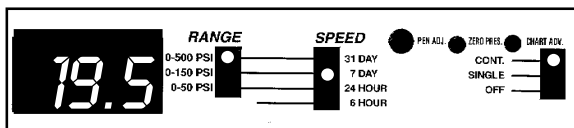

### Applications

- Low Voltage or 4-20 ma control circuits
- Process control applications
- Manufacturing

### Features/Benefits

- Choose voltage or current measurements
- Voltage Range 0 – 5V, 0-10 mV
- Current Range 0 – 20 mA, 4-20 mA
- Programmable speed and voltage or current ranges
- Snap-on support legs

PART NO.	OPERATING VOLTAGE
CR87V	110-120V, 50/60Hz.
CR87V220	220-240V, 50/60Hz.

### CR87V Series Recording Charts

6 HRS.	24 HRS.
CR87-57	CR87-58
7 DAYS	31 DAYS
CR87-59	CR87-60

# Chart Recorders



## Custom Series - Temperature Recorder

The Custom Series 6 Inch Temperature Recorders have the same general features as the CR87 Series, with the ability to customize your temperature measurement range. The custom unit has an internal temperature sensor and can be placed directly in the environment that it will monitor.

### Custom Series Specifications

- Chart Speed Accuracy -  $\pm 1.5\%$
- Chart Diameter - 6 inches
- Case Size - 9 1/4" x 7" x 2 3/4"
- Weight - 5 lbs.
- Battery Life - One Year
- Temperature Accuracy -  $\pm 2^\circ\text{F}$
- Temperature Sensor - Sensor Bi-metal

### Applications

- Designed for Refrigerators/ Freezer, Storage areas, Laboratories, Computer Rooms, etc.
- Custom temperature range means exact application needs.

### Features/Benefits

- Internal Bi-metal Sensor
- Custom Temperature and Speed Selection
- 9V Battery Operation (not included)
- AC Adapter (included)
- Snap-on support legs

PART NO.	WITH DISPLAY	TEMP. RANGE	RECORD TIME
SD120F7		-20°F to 120°F	7 Days
SD120F24		-20°F to 120°F	24 Hrs
SD100F7		0°F to 100°F	7 Days
SD50C7		-30°C to 50°C	7 Days

### Custom Series Recording Charts

SD MODELS	7 DAYS	24 HOURS
-20°F to 120°F	S20120F7	S20120F24
0°F to 100°F	S0100F7	S0100F24
45°F to 90°F	S4590F7	S4590F24
-30°C to 50°C	S3050C7	S3050C24
0°C to 45°C	S045C7	S045C24

**Note:** Standard 6" diameter recording charts are available for Fahrenheit and Celsius Recorders, and are packaged in quantities of 60 per box.

## Additional Recorder Accessories



### Type J Thermocouple Wire with Sensor for CR86/CR87

PART NO.	DESCRIPTION	PART NO.	DESCRIPTION
CR15B	15' wire with 4" stainless steel sensor (included)	CR75B	75' wire with 4" stainless steel sensor
CR25B	25' wire with 4" stainless steel sensor	CR100B	100' wire with 4" stainless steel sensor
CR50B	50' wire with 4" stainless steel sensor		



### Power Adapters

(FOR CR87B, CR87E, CR87P, CR87HT, CR86, CRTH2 & CRTT2)

PART NO.	INPUT	OUTPUT
CRT (USA)	120 VAC	12 VDC
CRT220 (Europe)	220 VAC	12 VDC
CRT220UK (England)	220 VAC	12 VDC

(FOR CUSTOM SERIES)

PART NO.	INPUT	OUTPUT
DPGT (USA)	120 VAC	9 VDC
DPGT220US (USA)	220 VAC	9 VDC
DPGT220UK (England)	220 VAC	9 VDC
DPGT220EU (Europe)	220 VAC	9 VDC



### Extension Cable for Event Sensors (KEV, KEL, KES) and CR87PA Pressure Sensor

PART NO.	DESCRIPTION
CABLE6	6' cable
CABLE15	15' cable
CABLE25	25' cable



### Nonsubmersible Type Air Sensor for CRTH2 & CRTT2

PART NO.	DESCRIPTION
THP5(CRTH2)	15' with plug-in jack
TTP5(CRTT2)	15' with plug-in jack



### Type J Thermocouple Wire for Sensors CR87J

PART NO.	DESCRIPTION
TCW25	25' wire only
TCW50	50' wire only
TCW75	75' wire only
TCW100	100' wire only



### Replacement Pens

PART NO.	DESCRIPTION
CRPEN	Black pen
CRPENR	Red pen
CRPENB	Blue pen

# Chart Recorders

## Recorder Specifications

	CR87B/J	CR87HT	CR87P	CR87V	CR87E
Ambient operating temperature range	32°F to 140°F (0°C to 60°C)	32°F to 140°F (0°C to 60°C)	32°F to 140°F (0°C to 60°C)	32°F to 140°F (0°C to 60°C)	32°F to 140°F (0°C to 60°C)
Ambient operating relative humidity	96% maximum	96% maximum	96% maximum	96% maximum	96% maximum
<b>CR87B</b> chart speed selectable	6 hours, 24 hours, 7 days, 31 days	6 hours, 24 hours, 7 days, 31 days	6 hours, 24 hours, 7 days, 31 days	6 hours, 24 hours, 7 days, 31 days	6 hours, 24 hours, 7 days, 31 days
<b>CR87J</b> chart	6 hours, 24 hours, 7 days	6 hours, 24 hours, 7 days	6 hours, 24 hours, 7 days	6 hours, 24 hours, 7 days	6 hours, 24 hours, 7 days
Chart rotation mode	Single turn or continuous	Single turn or continuous	Single turn or continuous	Single turn or continuous	Single turn or continuous
Chart speed accuracy	±1%	±1%	±1%	±1%	±1%
Chart diameter	6 inches	6 inches	6 inches	6 inches	6 inches
Display	3 digit LED 0.5"	3 digit LED 0.5"	3 digit LED 0.5"	3 digit LED 0.5"	3 digit LED 0.5"
Primary power supply	120 VAC, 50/60Hz. (220-240 VAC, 50/60Hz. optional - CR87B-220) 12 Volt vehicle operation with optional adapter	120 VAC, 50/60Hz. (220-240 VAC, 50/60Hz. optional - CR87HT22C) 12 Volt vehicle operation with optional adapter	120 VAC, 50/60Hz. (220-240 VAC, 50/60Hz. optional - CR87PB) 12 Volt vehicle operation with optional adapter	120 VAC, 50/60Hz. (220-240 VAC, 50/60Hz. optional - CR87V-220)	120 VAC, 50/60Hz. (220-240 VAC, 50/60Hz. optional - CR87V-220)
Battery backup	(8) AA Alkaline batteries (not supplied)	(8) AA Alkaline batteries (not supplied)	(8) AA Alkaline batteries (not supplied)	(8) AA Alkaline batteries (not supplied)	(8) AA Alkaline batteries (not supplied)
Battery Life	48 hours continuous use	48 hours continuous use	48 hours continuous use	48 hours continuous use	48 hours continuous use
Recording Pen	Ink type	Ink type	Ink type	Ink type	Ink type
Case Size	9 1/4" x 7 1/4" x 2 3/4"	9 1/4" x 7 1/4" x 2 3/4"	9 1/4" x 7 1/4" x 2 3/4"	9 1/4" x 7 1/4" x 2 3/4"	9 1/4" x 7 1/4" x 2 3/4"
Weight	4 lbs., 7 oz.	4 lbs., 7 oz.	4 lbs., 7 oz.	4 lbs., 7 oz.	4 lbs., 7 oz.
Pressure Range			0 to 500 PSI, 0 to 150 PSI		
PSI Model			0 to 50 PSI,		
Pressure Range BAR Model			0 to 35 BAR, 0 to 10 BAR		
Voltage Ranges (Selectable)				0-100mv 0-5V	
Current Range				0-20ma, 4-20ma	
LED Display				0-5.00 Volts 0-100 mV, 0-20.0 ma	
Voltage Accuracy				0-5.00 Volts ±0.01 Volt 0-100mV ±1mV	
Current Accuracy				0-20ma ±0.1mA 4-20ma ±0.1mA	
Temp. Scale Selectable (Fahrenheit)	-40°F to 30°F, -20°F to 50°F 50°F to 120°F	0°F to +250°F, 0°F to 500°F, 500°F to 1000°F			
Temp. Scale Selectable (Celsius)	-40°C to 0°C, -30°C to 10°C 10°C to 50°C	0°C to 120°C, 0°C to 250°C 250°C to 500°C			
Temperature Accuracy	±1°C or ±2°F	±1°C or ±2°F			
Pressure Accuracy			±1% F.S.		
Temperature Sensor	15' long sensor wire with 4" Stainless Steel submersible temperature probe	6' long high temperature type "J" thermocouple wire probe. Can not be used in liquid or semi-solid.	±1% F.S.		
KEV Range					24 VAC to 270 VAC (50/60Hz.) 24 VDC to 180 VDC
KEL Range					Illumination threshold range 18 Lux to 1900 Lux ±20
KES Range					Sound threshold range 40 dB to 114 dB @ 1Khz ±20%
<b>EVENT PROBES</b>					
KEV					AC/DC Voltage detecting with two wire clip leads
KEL					A sensitive photocell
KES					A sensitive audio transducer

# Chart Recorders

## Universal Recorder/Service Logger

The CR4 six (6) inch Universal Chart Recorder offers the ultimate in flexibility. Choose one of 5 sensors for your application, connect it to the CR4 Universal Recorder, make desired speed selection and start recording.

When your application calls for a different sensor, just change probes for the same recorder.

If you prefer to log data and download to a computer for analysis, the SL4 Service Logger has the same great flexibility as the CR4. The same probes can be used with the SL4.

MADE IN THE  
USA



CR4



SL4

### Features/ Benefits

- Automatic Probe recognition
- Front panel touch pad
- Full Time data view
- Memory backup (CR4)
- Interchangeable probes
- Field calibration of probes
- Independent Channel Alarms (CR4)
- PC software included (SL4) (Windows 95 & 98 compatible only)

### 5 Interchangeable Probes

- KTH Temperature and Humidity Probe
- KTT Dual Temperature Probes
- KTP Temperature and Pressure Probes
- KPP Dual Pressure Probes
- KTE Temperature/Event Probes

### CR4 & SL4 Specifications

	CR4	SL4
Chart Diameter	6 inches	
Recording Time		5 hrs. to 40 days
Chart Rotation Mode	Continuous or Single turn	
Memory		16 K non-volatile
Chart Rotation Speed	1.5, 3, 6, 12 & 24 hrs, 7 & 31 days	
Printer Interface		Parallel (centronics compatible)
Chart Speed Accuracy	±1%	
Charts	60 assorted included	
Display	LCD (2 line)	LCD (2 line)
Temperature Alarm Range	-20°F to 120°F (-30°C to 50°C)	
Relative Humidity Alarm Range	0 to 95% (Non-Condensing)	0 to 95% (Non-Condensing)
Pressure Alarm Range	0 to 500 PSI ( 0 to 35 Bar)	
Alarm Delay	NO DELAY, 10 mins., 30 mins., 1 hr. or 2 hrs.	
Remote Alarm Connection	NO, 48 VAC/DC, 0.1 A resistive load	
Operating Temperature	32°F to 120°F (0°C to 49°C)	32°F to 150°F (0°C to 65°C)
Primary Power	115 VAC, 50/60 Hz (230 VAC, 50/60 Hz optional)	115 VAC, 50/60 Hz (230 VAC, 50/60 Hz optional)
Alternate Power	12 V vehicle operation (need optional adapter)	12 V vehicle operation (need optional adapter)
Battery backup	8 AA alkaline batteries	9 V battery
Battery Life	48 hrs. continuous	24 hrs.

### CR4 & SL4 Accessories

PART NO.	DESCRIPTION	CR4	SL4	KTH	KTT	KTP	KPP	KTE
KTH	Temperature/ Humidity Probe	*	*					
KTT	Dual Temperature Probes	*	*					
KTP	Temperature and Pressure Probes	*	*					
KPP	Dual Pressure Probes	*	*					
KTE	Temperature/ Event Probes	*	*					
CABLE10H	Extension cable for KTH (2 max)			*				
CABLE6	6 ft. cable for sensor probes				*	*	*	*
CABLE15	15 ft. cable for sensor probes				*	*	*	*
CABLE25	25 ft. cable for sensor probes				*	*	*	*
TP6	Temperature sensor with 6 ft. wire				*	*		
TP15	Temperature sensor with 15 ft. wire				*	*		
CRPEN	Black Recorder Pen	*						
CRPENR	Red Recorder Pen	*						
CRPENB	Blue Recorder Pen	*						
CR4CABLE	RS232 Data Cable	*						
PC6	6 ft. Printer cable		*					
CC6	6 ft. Computer Transfer cable		*					
CRT	115 VAC Power Adapter	*	*					
CRT220	220 VAC Power Adapter	*	*					
MCASE	Carrying Case		*					

## Universal Recorder Probes



### KTH - Temperature/Humidity Probe

Complete with combination temperature, humidity probe. Allows for precision measurement of temperature, humidity and dew point. (Non-Condensing). Probe can be extended up to 25 feet, use p/n CABLE10H (max)



### KTT - Dual Temperature Probes

Complete with two precision temperature probes. Allows for two independent temperature measurements. Includes adapter and connecting cable. Perfect for refrigerators, freezers, indoor-outdoor recording, etc. Temperature probe can be extended 20', use P/N CABLE10T (2 max/probe)



### KTP - Temperature/ Pressure Probes

Complete with independent precision pressure and temperature probes. Measures and records temperature and pressure simultaneously. Ideal for solving intermittent compressor problems. Includes a connecting cable and adapter. Perfect for refrigerators, freezers, indoor-outdoor recording, etc. Temperature probe can be extended 20', use P/N CABLE10T (2 max/probe)



### KPP - Dual Pressure Probes

Complete with two pressure probes. Measure and record two pressures simultaneously. Includes connecting cable and adapter.



### KTE - Temperature/Event Probes

Complete with precision temperature probe, event probe, a connecting cable and adapter. Allows the service engineer to analyze various equipment running cycles.

### Interchangeable\* Probes for CR4 and SL4

PROBE TYPE	PART NO.	TEMP RANGE/ ACCURACY	VOLTAGE RANGE	RH RANGE/ ACCURACY	PRESS RANGE/ ACCURACY	DEW POINT RANGE
Temp/RH	KTH	-40°F to 130°F ±2°F (-40° to 55°C ±1°C)	—	0-95% at 32° to 130°F ±2% (0° to 55°C) ambient	—	32° to 130°F (0° to 55°C)
Temp/Temp	KTT	-40°F to 130°F ±2°F (-40° to 55°C ±1°C)	—	—	—	—
Temp/Press	KTP	-40°F to 130°F ±2°F (-40° to 55°C ±1°C)	—	—	0-500 PSI (0-35 BAR) ±1%FS	—
Press/Press	KPP	—	—	—	0-500 PSI (0-35 BAR) ±1%FS	—
Temp/Event	KTE	-40°F to 130°F ±2°F (-40° to 55°C ±1°C)	24 VAC-270VAC (24 VDC-180VDC)	—	—	—

\*All probes can be used with the Service Logger and the Universal Recorder.

## DR Series

The DR disposable temperature recorder is an inexpensive, one time use temperature recorder - indispensable for HVAC/R uses. It gives an accurate strip chart recording of a wide ambient temperature range. It can be easily changed on the job!

### Applications

- Monitoring temperature sensitive goods in-transit, walk-in boxes, warehouses, HACCP and more.

### Features

- Pull TAB to start
- Detachable three part water resistant job information form
- Unique serial number on chart and recorder for positive identification
- HACCP documentation
- NIS traceable calibration
- ABS Plastic enclosure

PART NO.	
DR10	10 days
DR40	40 days

### Specifications

Temperature Range	-20°F to 100°F (-28°C to 38°C)
Temperature Accuracy	±2°F (±1°C) or better
Day Spans	DR10 10 Day (°F & °C) DR40 40 Day (°F & °C)
Chart Resolution	10 Day 2.50" per day
Power/Shelf Life	1.5 volt AA battery 1 year from date of purchase
Calibration	NIST Traceable
Tamper-Proof	Pre-sealed at the factory
Security Seal	
Case Quantity	40 instruments
Enclosure	ABS plastic
Weight/Dimensions	10.5 oz (297.7 gm) 6.50" L x 3.50" W x 2.56" H 16.51 cm x 6.50 cm x 8.89 cm

1 - Hazard Analysis Critical Control Points  
2 - HACCP Required \* DR10 - Replaces DR5



# Chart Recorders

## Universal Recorder Charts

KTH RANGE 1	KTH RANGE 2	12 HR	24 HR	7 DAY	31 DAY
-20°F to 120°F	0-100% HUMIDITY	E20120F12	E20120F24	E20120F7	E20120F31
-20°F to 50°F	0-100% HUMIDITY			E2050F7	E2050F31
40°F to 110°F	0-100% HUMIDITY	E40110F12	E40110F24	E40110F7	E40110F31
-30°C to 50°C	0-100% HUMIDITY	E3050C12	E3050C24	E3050C7	E3050C31
-30°C to 10°C	0-100% HUMIDITY	E3010C12	E3010C24	E3010C7	E3010C31
5°C to 45°C	0-100% HUMIDITY	E545C12	E545C24	E545C7	E545C31
KTT RANGE 1	KTT RANGE 2	12 HR	24 HR	7 DAY	31 DAY
-20°F to 120°F	-20°F to 50°F	CRTT2-2	CRTT2-1	CRTT2-3	CRTT2-21
-20°F to 50°F	40°F to 110°F	CRTT2-5	CRTT2-4	CRTT2-6	CRTT2-19
40°F to 110°F	-20°F to 120°F	CRTT2-8	CRTT2-7	CRTT2-9	CRTT2-20
-30°C to 50°C	5°C to 45°C	CRTT2-11	CRTT2-10	CRTT2-12	
5°C to 45°C	-30°C to 10°C	CRTT2-14	CRTT2-13	CRTT2-15	CRTT2-24
-30°C to 10°C	-30°C to 50°C	CRTT2-17	CRTT2-16	CRTT2-18	CRTT2-23
KTE RANGE 1	KTE RANGE 2	12 HR	24 HR	7 DAY	31 DAY
-20°F to 120°F	ON/OFF			V20120F7D	V20120F31
-20°F to 50°F	ON/OFF	V2050F12		V2050F7	V2050F31
40°F to 110°F	ON/OFF	V40110F12	V40110F24	V40110F7	V40110F31
-30°C to 50°C	ON/OFF	V3050C12	V3050C24	V3050C7	V3050C31
5°C to 45°C	ON/OFF	V545C12	V545C24	V545C7	V545C34
-30°C to 10°C	ON/OFF	V3010C12	V3010C24	V3010C7	V3010C31
KPP RANGE 1	KPP RANGE 2	12 HR	24 HR	7 DAY	31 DAY
0-50 PSI	0-150 PSI	CRPP2-1	CRPP2-7	CRPP2-13	CRPP2-19
0-50 PSI	0-500 PSI		CRPP2-8	CRPP2-14	CRPP2-20
0-150 PSI	0-500 PSI	CRPP2-3	CRPP2-9	CRPP2-15	
0-3.5 BAR	0-10 BAR	CRPP2-4	CRPP2-10	CRPP2-16	CRPP2-22
0-3.5 BAR	0-35 BAR	CRPP2-5	CRPP2-11	CRPP2-17	CRPP2-23
0-10 BAR	0-35 BAR	CRPP2-6	CRPP2-12	CRPP2-18	CRPP2-24
KTP RANGE 1	KTP RANGE 2	12 HR	24 HR	7 DAY	31 DAY
-20°F to 120°F	0-50 PSI	CRTP2-1			
-20°F to 120°F	0-150 PSI		CRTP2-11	CRTP2-38	
-20°F to 120°F	0-500 PSI	CRTP2-3	CRTP2-12	CRTP2-39	
-20°F to 50°F	0-50 PSI	CRTP2-4	CRTP2-13	CRTP2-40	CRTP2-58
-20°F to 50°F	0-150 PSI	CRTP2-5	CRTP2-14	CRTP2-41	CRTP2-59
-20°F to 50°F	0-500 PSI	CRTP2-6	CRTP2-15	CRTP2-42	CRTP2-60
40°F to 110°F	0-50 PSI	CRTP2-7	CRTP2-16	CRTP2-43	CRTP2-61
40°F to 110°F	0-150 PSI	CRTP2-8	CRTP2-17	CRTP2-44	CRTP2-62
40°F to 110°F	0-500 PSI	CRTP2-9	CRTP2-18	CRTP2-45	CRTP2-63
-30°C to 50°C	0-3.5 BAR	CRTP2-19	CRTP2-28	CRTP2-46	CRTP2-64
-30°C to 50°C	0-10 BAR	CRTP2-20	CRTP2-29	CRTP2-47	CRTP2-65
-30°C to 50°C	0-35 BAR		CRTP2-30	CRTP2-48	CRTP2-66
-30°C to 10°C	0-3.5 BAR	CRTP2-22	CRTP2-31	CRTP2-49	CRTP2-67
-30°C to 10°C	0-10 BAR	CRTP2-23	CRTP2-32	CRTP2-50	CRTP2-68
-30°C to 10°C	0-35 BAR	CRTP2-24	CRTP2-33	CRTP2-51	CRTP2-69
5°C to 45°C	0-3.5 BAR	CRTP2-25	CRTP2-34	CRTP2-52	CRTP2-70
5°C to 45°C	0-10 BAR	CRTP2-26	CRTP2-35	CRTP2-53	CRTP2-71
5°C to 45°C	0-35 BAR	CRTP2-27	CRTP2-36	CRTP2-54	CRTP2-72



## DA86420 4 in 1 Multi-Socket

### Features/Benefits

- Replaces the four most common nut drivers. SAE socket sizes 1/4", 3/8", 5/16", 7/16".
- Telescoping action provides two socket sizes at each end.
- High-torque grip textured, non-slip surface.
- 12/display box



## Security Multi-Driver

### Features/Benefits

- Features extra-long 3" nosepiece reaches even recessed fasteners.
- Includes 14 security tips plus 2 standard tips on eight 3" long, double-ended bits.

### Bits Included

HEX SECURITY	1/8", 9/64", 5/32", 3/16"
SPANNER	4, 6, 8, 10
ROBERTS SECURITY	1, 2
TORX SECURITY	10, 15, 20, 25
PHILLIPS	2
SLOT	7/32"

### PART NO.

<b>SAB454</b>	Countertop Display of 12
<b>SAB444</b>	Clamshell Packaging



## Classic Multi-Driver

### Features/Benefits

- Standard size driver. Replaces 16 of the most frequently used bits.

### Bits Included

HEX	3/32", 1/8", 5/32", 3/16"
ROBERTS	2, 3
SLOT	1/4", 3/16"
TORX	15, 20, 25, 30
PHILLIPS	0, 1, 2, 3

### PART NO.

<b>SAB243</b>	Countertop Display of 12
<b>SAB233</b>	Clamshell Packaging



## Ratchet Multi-Driver

### Features/Benefits

- Heavy-duty reversible ratchet mechanism.
- Adjustable angle nosepiece swivels 180° and locks into the angle you need.
- Also available with a 7-piece SAE socket set which includes these sockets: 3/16", 5/16", 3/8", 7/16", 11/32", 1/2", Plus adapter bit.

### Bits Included

HEX	3/32", 1/8", 5/32", 3/16"
ROBERTS	2, 3;
SLOT	1/4", 3/16"
TORX	15, 20, 25, 30
PHILLIPS	0, 1, 2, 3

### PART NO.

<b>DA86400</b>	Clamshell Packaging
<b>SAB515</b>	Driver with SAE Socket Set (Clamshell Packaging)



## SAB710 Ratio Multi-Driver

### Features/Benefits

- Multi-driver replaces 16 screwdrivers.
- 4 to 1 ratio nosepiece turns four times with each turn of the handle.
- 1 to 1 ratio nosepiece turns with the handle.
- Reversible ratchet changes direction quickly with one hand, even during use.
- 8 extra-long (3") double-ended bits. Bits store in the handle and a 1/4" nut driver in the nose.

### Bits Included

HEX	3/32", 1/8", 5/32", 3/16"
ROBERTS	2, 3
SLOT	1/4", 3/16"
TORX	15, 20, 25, 30
PHILLIPS	0, 1, 2, 3

# Tools

## Hi Torq 6 in 1 Driver

### Features/Benefits

- 6 in 1 driver available with standard or security (tamper-proof) bits. Has a nut driver on each end and double-ended bits.
- Handle ergonomic. Oversized, tapered, three-sided, maximizes torque force, minimizes exertion for less hand fatigue.
- Kraton rubber grip handle coating tacky, non-sticky surface, for a non-slip grip—even when wet or oily.



### Standard Bit Load

PHILLIPS	1, 2;
SLOT	3/16", 1/4"
NUT DRIVER	1/4", 5/16"

### Security Bit Load

TORX SECURITY	15, 20, 25, 30
NUT DRIVER	1/4", 5/16"

### PART NO.

<b>DA76440</b>	Standard
<b>DA76450</b>	Security

## DA76460 Flexible Lighted Magnet Pickup

### Features/Benefits

- LED technology. Super-bright lights, no light bulbs to replace.
- Efficient illumination of the search area. Light is located at the magnet end; 23" total length.
- Strong 5 pound magnet.
- Magnet is encased in a brass shield. Directs the magnetic force to the tip, won't attract peripheral objects.
- Flexible pickup. Thin shaft that bends to any angle without breaking.
- Uses 3 button cell batteries (357/SR4 – included).



## Telescoping Lighted Magnet Pickup

### Features/Benefits

- Telescoping magnet pickup telescopes to 26", collapses to 7"
- Telescoping pickup and mirror.
- Oversized mirror (2.25" diameter) with a universal joint that adjusts to any angle telescopes to 36", collapses to 8"



### PART NO.

<b>ELB913</b>	Telescoping Magnet Pickup (Pickup Only)
<b>ELB910</b>	Telescoping Pickup & Mirror (3 pc. Set Includes Pickup, Mirror, Case)

## ELB717 Nut Driver Set, 7 pc. SAE

### Features/Benefits

- Color-coded hollow shafts accommodate longer fasteners.
- Extra-deep sockets securely grip nuts and bolts.
- Includes 7 SAE sizes: 3/16", 1/4", 5/16", 11/32", 3/8", 7/16", 1/2".



## RC5003 Utility Jack Knife

### Features/Benefits

- Lock-back design holds blade securely during use, folds to 3.5".
- Patented quick change blade mechanism allows you to slide in a new blade without disassembling the knife or using tools.
- No special blades to order. Accepts double-notched standard-and contractor- blades.
- Includes 5 spare blades in reusable blade holder.
- Stainless steel belt clip.



## RC5010 Mini Utility Jack Knife

### Features/Benefits

- Folds to 2.5". Compact, fits conveniently on an included key ring.
- Same quick change mechanism and heavy-duty construction
- 10 spare blades in reusable blade holder are included. Mini replacement blades are sold separately.



### PART NO. DESCRIPTION

<b>RC5010</b>	Mini Utility Knife
<b>RC5019</b>	Mini Replacement Blades



## 2 in 1 Cutter/Stripper

### Features/Benefits

- Cuts wire with one end, grabs and strips wire with the other.
- Stripper self-adjusts to wire; no stripping holes.
- 5" model strips stranded wire sizes 26 to 14 awg.
- 6" model strips electrical wire sizes 14 to 10 awg.
- Cutting head is full-flush cutting and low profile with stainless steel, induction-hardened jaws.

PART NO.	DESCRIPTION
ELB250	5" for Low Voltage Wire
ELB251	6" for Electrical Wire



## RC4300 3 in 1 Multi Pliers

### Features/Benefits

- Three interchangeable plier heads lock into place, won't slip during use.
- Double lever design yield twice the force of standard pliers.
- Handle of chrome molybdenum and PVC, warranted for life.
- Plier heads are induction-hardened carbon steel, which carry a three-year warranty.
- Set includes long nose, diagonal cutting and combination plier heads in a Velcro-close ripstop nylon holster.



## Heavy Duty Pliers Assortment

### Features/Benefits

- Super heavy-duty oversized cross section, induction-hardened cutting edges and hot-riveted joints.
- Two-color textured non-slip handles.
- Professional quality materials and construction make this assortment a great value.

PART NO.	DESCRIPTION
ELB305	8" Diagonal Cutter
ELB304	7" Diagonal Cutter
ELB301	10" Crimping
ELB312	8.5" Linesman



## Heavy Duty Pliers-11" Extended

### Features/Benefits

- Specialty pliers, 11" reach and a choice of nose angles.
- Professional quality.
- Two-color textured handles.
- Model selection includes straight nose, or curves of 20°, 45°, or 90°.

PART NO.	DESCRIPTION
ELB320	Straight
ELB321	45° Angle



## ELB714 Torpedo Level 9"

### Features/Benefits

- Three 360° vials are tinted for easy reading: one plumb, one level, one 45°.
- Magnetic strip and top read window.



## ELB340 Dual Snap Ring Pliers

### Features/Benefits

- Lighten your toolbox.
- All-in-one tool removes both internal and external snap rings.
- Spring-loaded over sized handle, cushioned for comfortable use.



## Heavy Duty Pliers-Telecom

### Features/Benefits

- The most efficient pliers for telecom use - cut, strip and crimp with one tool.
- Long nose pliers, one skinning hole to strip 22 awg wire and feature a cross-jaw grip.
- Diagonal cutting pliers, two skinning holes for stripping 16 and 22 AWG wire.
- Quality construction, drop-forged chrome vanadium steel with hot-riveted joint.
- Both models have induction-hardened cutting edges and crimper features between handles.
- Velcro-close ripstop nylon holster included with each tool.

PART NO.
ELB101 Long Nose

# Tools



## Ratcheting Pipe Wrench

### Features/Benefits

- Oversized jaws automatically set-to-fit for one-handed operation.
- Ratcheting jaw doesn't require resetting between turns.
- Power jaw clamps tighter as you increase torque force.
- 360° Swivel head allows full leverage in tight spots.
- Heavy-gauge chrome vanadium steel has excellent durability.

### PART NO.

**RC3110** 10" Wrench Opens to 4.5"

**RC3114** 14" Wrench opens to 2.5"



## Precision Adjustable Wrench

### Features/Benefits

- Oversized jaw opens 18% wider than standard wrenches
- Dual calibrated jaw.
- Oversized grip has superior balance to reduce hand fatigue.
- Constructed of heavy-gauge, industrial-quality steel insuring durability.

### PART NO.

**RC2106** 6" spans 15/16"

**RC2108** 8" spans 1 1/8"

**RC2110** 10" spans 1 5/16"

**RC2112** 12" spans 1 9/16"



## DA76210 12" Box Joint Pump Pliers

### Benefits/Features

- Heavy-duty box joint construction can't torque out, won't loosen with use.
- Self-gripping jaw pattern provides tight, secure grip, even on slippery pipes.
- Cushioned, non-slip grip.
- Industrial quality chrome vanadium steel with induction-hardened teeth.



## ELB713 Electrician's Fish Stick Set

### Features/Benefits

- Economical, efficient, and snarl-free way to pull or push wire.
- Safe, non-conductive flexible PVC plastic, bends easily around obstacles.
- Five-piece set contains 5 connectable rods, 24" long and 3/8" diameter.
- Includes 2 bull tip slotted heads for attaching wire.
- Rods feature rust-resistant internal connectors.
- Set includes nylon carrying case.



## ELB402 Quick Release Tubing Cutter

### Features/Benefits

- Auto ratchet closure sets to pipe automatically.
- Quick release, spring-loaded retractor releases pipe instantly.
- Lightweight aluminum body with built-in reamer feature.
- Cuts 1/4" to 2" o.d. copper tubing.



## RC1220 Pry-Angle™ Adjustable Prybar

### Features/Benefits

- Clawhead is indexed to lock into 5 positions: 180° (straight), 155°, 130°, 105°, 80°.
- Super tough locking mechanism with thumb lever allows one handed angle changes.
- Industrial quality high carbon steel construction meets ANSI standard, rated at 300 foot/lbs. torque.



## ELB400 Mini Tubing Cutter

### Features/Benefits

- Tough, lightweight aluminum cutter for copper pipe 1/8" – 7/8" o.d.
- One Spare wheel included.

# Tools & Accessories



## ELB721 Mini Cable Tie Gun

### Features/Benefits

- The right cable tie gun for small jobs.
- Compact size accommodates plastic cable ties up to 0.25" in width.
- Twist cable gun to cut and trim off excess cable tie length.



## Fish Tape

### Features/Benefits

- Trigger for constant tension and finger grips around the reel keep the tape under control and retracting tightly.
- Tape reel cleans the tape as it retracts.
- Refills sold separately.

PART NO.	DESCRIPTION
ELB710	50' Length
ELB711	100' Length



## ELB701-L Cable Splicing Knife

### Features/Benefits

- Coping-type blade is machined from fine cutlery steel.
- Non-slip, textured rubberized handle.
- Heavy-duty leather carrying sheath included.



## ELB400

### Features/Benefits

- Prevent injuries from sharp cable ties—the safety cutter has a square cutting profile that blunt-cuts wire ties and other plastics.
- Professional quality, spring-loaded handles with precision ground, hardened steel jaws.
- To leave a blunt edge on wire tie bundles, place flush edge of cutter head toward the bundle, then cut.



## FBP100 - Fan Blade Puller

### Features/Benefits

- Sturdy, heavy duty steel
- 5/8" steel center shaft
- 4 pull fingers
- Alignment tool included
- Has flats for wrench
- Fine thread version provides additional torque & pulling power



## Blower Wheel Pullers

A fast and easy method to remove blower wheel from shaft without damage to the blower, blower motor or shaft.

PART NO.	DESCRIPTION
SF3500	Drive bolt shank and 1 1/4" hub
SF3510	Drive bolt shank and 1 3/8" hub
SF3515	1 3/8" hub only
SF3525	1 1/2" hub only
SF3535	1 5/8" hub only
SF3570	Blower wheel puller kit

# Tools & Accessories



## CTP1- Capillary Tube Cutter

5" stripper and cutter. Fast, efficient and all purpose.



## TC2 - Heavy Duty Tube Cutter

- For clean cuts in hard or soft copper aluminum, brass, thin wall steel and stainless steel.
- Rollers have flared cut off groove
- Complete with foldaway reamer blade and spare cutting wheel.
- Cuts tubes from 1/8" thru 1 1/8" O.D.
- Replacement cutting wheel p/n TC2W



## UFC1 - Fin Comb

Cleans and straightens fins for better operating efficiency.



## FPT10, FPT13 & FPT15 Fin Jack

Straightens and separates bent fins quickly and easily. One tool can be used for up to 3 sizes of fins.

PART NO.	DESCRIPTION
FPT10	9 & 10 Fins per inch
FPT13	11, 12 & 13 Fins per inch
FPT15	14, 15 & 16 Fins per inch



## FCR6 - Handy Ring Fin Comb Set

Six of the most popular Fin Combs covering twelve different size fins on a convenient ring. Includes FC0810, FC0915, FC1113, FC1214, FC1617, and FC1820.

PART NO.	FINS PER		COLOR	PART NO.	FINS PER	
	INCH	INCH			INCH	COLOR
FC0810	8 and 10		Orange	FC1617	16 and 17	Lime
FC0915	9 and 15		Yellow	FC1820	18 and 20	Red
FC1113	11 and 13		Blue	FC2224	22 and 24	Purple
FC1214	12 and 14		Green			



## Fin Combs

Straighten and clean evaporator and condenser fins.



## SF4311- "FasTap" Tube Piercing Pliers

- Fast refrigerant recovery: Just clamp and recover
- Tubing sizes 1/4" to 7/8" OD
- Replaceable self-sharpening tip
- Simple to use
- Light weight



## SF4314 - Tube Piercing Pliers Replacement Tip



## SF3970 - Internal Temperature Reading Tool

Take Internal Temperatures of Refrigerant Lines digitally.

- Accurately adjust superheat
  - Simple instructions
  - Inserts through access fitting (supplied)
- Includes: Core Removal Tool and Digital Thermometer  
Replaces SF3940 AND SF3960



## DHS55 - Digital Handheld Scale

This compact handheld scale provides quick measurements for your refrigeration applications.

### Features/Benefits

- 55 lbs max scale
- 2% accuracy
- One button operation
- Auto shut off
- Lbs/Kgs switchable
- Max weight memory
- 9 V battery included



## HVT2 - Safe-T-Tester Screwdriver

- 110-220 VAC
- Light in handle indicates power



## P89 - Voltage Detector

- 12-440 VAC

• Non-contact Voltage Detection



# Tools & Accessories



## Telescoping Tools

Match Clip, Magnet, and Inspection Mirrors

### Features/Benefits

- Double ball joint head adjustment
- Extendable/retractable design
- Magnified glass mirror available with IM4
- Carry pouch included
- Glass Mirrors

PART NO.	DESCRIPTION	EXTENDED LENGTH
IM1	1.25" Round Glass Mirror, Pocket Clip	27"
IM2	1" x 2" Oval Glass Mirror, Pocket Clip	28"
IM3	2.25" Round Glass Mirror, Vinyl Grip Handle	14.5"
IM4	2.25" Round Magnifying Glass Mirror, Vinyl Grip Handle	14.5"
IM5	2.25" x 3.25" Rectangular Glass Mirror, Vinyl Grip Handle	15.5"
IMK3	Combination Tool, Pocket Clip Includes: Match Clip, Magnet, 2" Round Mirror & PVC Pouch	27"



## FWB1 - Fin Wisk Brush

### Features

- Long lasting, sturdy Bristle Design



## RCB1 - Refrigeration Coil Brush

### Features

- 27 1/2" long
- 12" brush length
- 1 1/2" and 3/4" bristle length



## Air Conditioning & Refrigeration Wrenches

PART NO.	DESCRIPTION
RW516	1/4" - 3/16" Sq. x 3/8" - 5/16" Hex
RW916	1/4" - 3/16" Sq. x 1/2" - 9/16" Hex
RWA10	Hex adapter for refrigeration wrenches



## UW1 - Universal Wrench

Ranges in sizes from 1/4", 5/16", 11/32", and 3/8".



## HK7 - Hex Key Wrench Set

Consists of seven 12" long hex wrenches: 5/64", 3/32", 1/8", 5/32", 3/16", 7/32" and 1/4".



## BJ10 - Belt-Jack Instant Belt Tightener

Designed to set belt tension and to help align pulleys on all belt driven units including blower motors, compressors, transmissions, and automotive components.

- Opens from 4 1/2" to 15" with extender
- Heavy duty 3/8-16 thread

## BJ10PLUS - Belt-Jack Instant Belt Tightener

Same as BJ10 Plus an extra 6" extension

# Tools & Accessories



## TC103 Test Cord

- 6', heavy duty, 16 gauge wire
- Male plug to medium duty spring clips
- 2 wire, black/red



## TC104

- 24", heavy duty, 16 gauge wire
- Female plug to medium size spring clips
- 3 wire, black/red/green



## TA3001

- 15' long, 1" nylon webbing
- Adjusts from 1' to 15'
- Ratchet handle w/ quick release
- Vinyl coated "S" hooks at each end
- 3000 lb. capacity



## THS60

- 5' long, 3/4" polypropylene web strap
- Reinforced grommet
- Spring loaded buckle at one end



## SR6N1- 6 in 1 Ratchet Screwdriver

**Sold in 12 pack display!**

- Ratchet Action
- 3-Settings:
  - Forward
  - Manual
  - Reverse
- Bit Sizes
  - Slotted: 3/16" (5mm) and 1/4" (6mm)
  - Phillips: #1 and #2
  - Nut Driver: 1/4" and 5/16"



## SAR21- 21 in 1 Angling Ratchet Screwdriver

**Sold in 6 pack display!**

- 21 Bit Sizes
- Multi-Position Angle
- Bit Storage

### Accessories

<b>70056A</b>	Replacement socketd w/holder
<b>70056B</b>	Replacement bits w/holder

# Terminals & Connectors

**SUPCO Terminals, Cable Clamps, Grommets, Heat Shrink Tubing, Cable and Duct Ties are available in three convenient packages:**

- The service pack is handy and low priced, ideal for small jobs.
- The BX (Box) which includes 50 or 100 pieces.
- The C Pack (Bag) which include 100 pieces.

## SWC Series - Nylon Cable Clamps



PART NO.	DESCRIPTION	PKG QTY
SWC03	Nylon Cable Clamp 3/16" (.187)	40
SWC04	Nylon Cable Clamp 1/4" (.250)	35
SWC05	Nylon Cable Clamp 5/16" (.3125)	35
SWC08	Nylon Cable Clamp 1/2" (.500)	25
SWC110	Nylon Cable Clamp 5/8"	20
SWCA1	Cable Clamps, Assorted, 1/8" to 1"	26

## SGV Series - Grommets, Vinyl (by panel hole size)



PART NO.	DESCRIPTION	PKG QTY
SGV05	Grommets 5/16" (.3125)	15
SGV06	Grommets 3/8" (.375)	13
SGV07	Grommets 7/16" (.437)	12
SGV08	Grommets 1/2" (.500)	12
SGV14	Grommets 7/8"	4
SGVA1	Assorted Grommets - Small	15
SGVA2	Assorted Grommets - Large	5

## SHS Series - Heat Shrink Tubing, Polyolefin 50% Shrink



PART NO.	DESCRIPTION	PKG QTY
SHS03	Heat Shrink Tubing 3/16" ID x 4"	8
SHS04	Heat Shrink Tubing 1/4" ID x 4"	7
SHS012	Heat Shrink Tubing 3/4" ID x 4"	4
SHS16	Heat Shrink Tubing 1" ID x 4"	3
SHSA1	Assorted 3/16", 1/4", 3/8" x 4"	7
SHSA2	Assorted 1/2", 3/4", 1" x 4"	4



PART NO.	SIZE / DESCRIPTION	PKG QTY
<b>Quick Disconnects - Insulated</b>		
T1001	12-10 .250 (1/4") female tab	15
T1001C	12-10 .250 (1/4") female tab	100
T1002	16-14 .250 (1/4") female tab	20
T2002	16-14 .187 (3/16") female tab	20
T2002C	16-14 .187 (3/16") female tab	100
T2004	22-18 .250 (1/4") female tab	20
T2004C	22-18 .250 (1/4") female tab	100



PART NO.	SIZE / DESCRIPTION	PKG QTY
<b>Quick Disconnects - Insulated</b>		
T1005	16-14 .250 (1/4") female fully insulated	10
T1005C	16-14 .250 (1/4") female fully insulated	100
T1007	18-22 .250 (1/4") female fully insulated	10
T1009	12-10 .250 (1/4") female fully insulated	10
T1009C	12-10 .250 (1/4") female fully insulated	100



PART NO.	SIZE / DESCRIPTION	PKG QTY
<b>Quick Disconnects - Insulated</b>		
T1021	.250 (1/4") double male tab	10
T1021C	.250 (1/4") double male tab	100



PART NO.	SIZE / DESCRIPTION	PKG QTY
<b>Quick Disconnects - Insulated</b>		
T1023	.250 (1/4") triple male tab	10
T1023C	.250 (1/4") triple male tab	100



PART NO.	SIZE / DESCRIPTION	PKG QTY
<b>Quick Disconnects - Insulated</b>		
T1003	16-14 .250 (1/4") male tab	20
T1004	12-10 .250 (1/4") male tab	15
T1004C	12-10 .250 (1/4") male tab	100
T2003	16-14 .187 (3/16") male tab	20
T2003C	16-14 .187 (3/16") male tab	100



PART NO.	SIZE / DESCRIPTION	PKG QTY
<b>Quick Disconnects - Insulated</b>		
T1006	16-14 .250 (1/4") male fully insulated	10
T1010	12-10 .250 (1/4") male fully insulated	10
T1010C	12-10 .250 (1/4") male fully insulated	100



PART NO.	SIZE / DESCRIPTION	PKG QTY
<b>Quick Disconnects - Insulated</b>		
T1022	.250 (1/4") double male tab	10
T1022C	.250 (1/4") double male tab	100



PART NO.	SIZE / DESCRIPTION	PKG QTY
<b>Quick Disconnects - Non Insulated</b>		
T1104	16-14 .250 (1/4") flag	20
T1104C	16-14 .250 (1/4") flag	100
T1106	16-14 .187 (3/16") flag	20
<b>Quick Disconnects - High Temp to 900 F</b>		
T1113	16-14 .250 (1/4") female x 90 degree flag	20
T1113C	16-14 .250 (1/4") female x 90 degree flag	100

# Terminals & Connectors



PART NO.	SIZE / DESCRIPTION	PKG QTY
<b>Quick Disconnects - Non Insulated</b>		
T1102	16-14 .250 (1/4") female tab	20
T1102C	16-14 .250 (1/4") female tab	100
T1105	16-14 .187 (3/16") female tab	20
T1105C	16-14 .187 (3/16") female tab	100
T1107	22-18 .110 (7/64") female tab	20
T2001	22-18 .110 (1/4") female tab	20
T2001C	22-18 .110 (1/4") female tab	100
<b>Quick Disconnects - High Temp to 900°F</b>		
T1111	16-14 .250 (1/4") female tab	20
T1111C	16-14 .250 (1/4") female tab	100
T1112	12-10 .250 (1/4") female tab	15
T1112C	12-10 .250 (1/4") female tab	100



PART NO.	SIZE / DESCRIPTION	PKG QTY
<b>Quick Disconnects - Non Insulated</b>		
T1110	16-14 .157 (5/32") bullet female	20
T1110C	16-14 .157 (5/32") bullet female	100



PART NO.	SIZE / DESCRIPTION	PKG QTY
<b>Quick Disconnects - Non Insulated</b>		
T1109	16-14 .250 (1/4") female tab w/insulation crimp	20
T1120	16-14 .312 (5/16") female tab w/insulation crimp	10
T1120C	16-14 .312 (5/16") female tab w/insulation crimp	100



PART NO.	SIZE / DESCRIPTION	PKG QTY
<b>Quick Disconnects - High Temp to 900°F</b>		
T1114	12-10 .250 (1/4") female x 90 degree flag	20
T1114C	12-10 .250 (1/4") female x 90 degree flag	100



PART NO.	SIZE / DESCRIPTION	PKG QTY
<b>Spade Flanged - Insulated</b>		
T1042	22-18 #8 stud 11/64" I.D.	20
T1042C	22-18 #8 stud 11/64" I.D.	100
T1043	16-14 #8 stud 11/64" I.D.	20
T1043C	16-14 #8 stud 11/64" I.D.	100
T1044C	16-14 #10 stud 13/64" I.D.	100



PART NO.	SIZE / DESCRIPTION	PKG QTY
<b>Spade - Insulated</b>		
T1047	22-18 #8 stud 11/64" I.D.	20
T1047C	22-18 #8 stud 11/64" I.D.	100
T1048	16-14 #10 stud 13/64" I.D.	20
T1049	12-10 #10 stud 13/64" I.D.	15
T1049C	12-10 #10 stud 13/64" I.D.	100
T1050	12-10 #8 stud 11/64" I.D.	15
T1050C	12-10 #8 stud 11/64" I.D.	100



PART NO.	SIZE / DESCRIPTION	PKG QTY
<b>Quick Disconnects - Insulated</b>		
T1027	16-14 .250 (1/4") male/female p.b.	10
T1027C	16-14 .250 (1/4") male/female p.b.	100
T1028C	22-18 .250 (1/4") male/female p.b.	100
T1029	12-10 .250 (1/4") male/female p.b.	10



PART NO.	SIZE / DESCRIPTION	PKG QTY
<b>Quick Disconnects - Non Insulated</b>		
T1103	16-14 .250 (1/4") male tab	20
T1103C	16-14 .250 (1/4") male tab	100



PART NO.	SIZE / DESCRIPTION	PKG QTY
<b>Quick Disconnects - Non Insulated</b>		
T1108C	16-14 .157 (5/32") bullet male	100



PART NO.	SIZE / DESCRIPTION	PKG QTY
<b>Rings - Insulated</b>		
T1030	22-18 #6 stud 9/64" I.D.	10
T1030C	22-18 #6 stud 9/64" I.D.	100
T1031C	22-18 #8 stud 11/64" I.D.	100
T1032C	22-18 #10 stud 13/64" I.D.	100
T1033	16-14 #8 stud 11/64" I.D.	20
T1034	16-14 #10 stud 13/64" I.D.	20
T1035	16-14 1/4 stud 17/64" I.D.	15
T1035C	16-14 1/4 stud 17/64" I.D.	100
T1036	12-10 #8 stud 11/64" I.D.	15
T1036C	12-10 #8 stud 11/64" I.D.	100
T1037	12-10 #10 stud 13/64" I.D.	15
T1037C	12-10 #10 stud 13/64" I.D.	100
T1038	12-10 1/4 stud 17/64" I.D.	15
T1039	16-14 3/8 stud 25/64" I.D.	15
T1039C	16-14 3/8 stud 25/64" I.D.	100
T1040C	12-10 3/8 stud 25/64" I.D.	100
T2033	16-14 #6 stud 9/64" I.D.	20
T2033C	16-14 #6 stud 9/64" I.D.	100
T2065	#8 1/4 stud 17/64" I.D.	15
T2065C	#8 1/4 stud 17/64" I.D.	100
T2066C	#6 1/4 stud 17/64" I.D.	100



PART NO.	SIZE / DESCRIPTION	PKG QTY
<b>Spade Flanged - Insulated</b>		
T1141	22-18 #8 stud 11/64" I.D.	20
T1141C	22-18 #8 stud 11/64" I.D.	100
T1142	22-18 #10 stud 13/64" I.D.	20
T1143	16-14 #8 stud 11/64" I.D.	20
T1143C	16-14 #8 stud 11/64" I.D.	100
T1144	16-14 #10 stud 13/64" I.D.	20

# Terminals & Connectors



PART NO.	SIZE / DESCRIPTION	PKG QTY
<b>Spade - Non Insulated</b>		
T1145	22-18 #10 stud 13/64" I.D.	10
T1145C	22-18 #10 stud 13/64" I.D.	100
T1146	16-14 #10 stud 13/64" I.D.	10
T1147	10-12 #10 stud 13/64" I.D.	10
T1147C	10-12 #10 stud 13/64" I.D.	100
T114750	WIRE CNCTR, SM, GRAY	50



PART NO.	SIZE / DESCRIPTION	PKG QTY
<b>Rings - Non Insulated</b>		
T1131	22-18 #8 stud 11/64" I.D.	20
T1131C	22-18 #8 stud 11/64" I.D.	100
T1133C	16-14 #8 stud 11/64" I.D.	100
T1134	16-14 #10 stud 11/64" I.D.	20
T1134C	16-14 #10 stud 11/64" I.D.	100
T1135	16-14 1/4" stud 17/64" I.D.	20
T1135C	16-14 1/4" stud 17/64" I.D.	100
T1136	12-10 #8 stud 11/64" I.D.	20
T1136C	12-10 #8 stud 11/64" I.D.	100
T1137	12-10 #10 stud 13/64" I.D.	20
T1137C	12-10 #10 stud 13/64" I.D.	100
T1138	12-10 1/4" stud 17/64" I.D.	15
T1138C	12-10 1/4" stud 17/64" I.D.	100
<b>Rings - High Temp to 900°F</b>		
T1115	16-14 #10 stud 13/64" I.D.	20
T1115C	16-14 #10 stud 13/64" I.D.	100
T1116	16-14 1/4" stud 17/64" I.D.	20
T1116C	16-14 1/4" stud 17/64" I.D.	100
T1117	12-10 #10 stud 13/64" I.D.	20
T1117C	12-10 #10 stud 13/64" I.D.	100
T1118	12-10 1/4" stud 17/64" I.D.	15



PART NO.	SIZE / DESCRIPTION	PKG QTY
<b>Line Tap Connector</b>		
T1061	22-18 line tap connector	10
T1061C	22-18 line tap connector	100
T1062C	16-14 line tap connector	100
T1064	12-10 line tap connector	5
T1064C	12-10 line tap connector	100



PART NO.	SIZE / DESCRIPTION	PKG QTY
<b>Butt Connectors</b>		
T1051	22-18 insulated - red	20
T1051C	22-18 insulated - red	100
T1052	16-14 insulated - blue	20
T1052C	16-14 insulated - blue	100
T1053	12-10 insulated - yellow	15
T1053C	12-10 insulated - yellow	100



PART NO.	SIZE / DESCRIPTION	PKG QTY
<b>Connectors and Adapters</b>		
T1121	.250 (1/4") 2 male x 1 female	10
T1121C	.250 (1/4") 2 male x 1 female	100



PART NO.	SIZE / DESCRIPTION	PKG QTY
<b>Butt Connectors</b>		
T1119	22-18 non insulated	20
T1119C	22-18 non insulated	100
T2067	#8 non insulated	20
T2067C	#8 non insulated	100
T2068	#6 non insulated	20
T2068C	#6 non insulated	100
T2111	16-14 non insulated	20
T2111C	16-14 non insulated	100



PART NO.	SIZE / DESCRIPTION	PKG QTY
<b>Connectors and Adapters</b>		
T1122	.250 (1/4") 2 male x 1 female	10



PART NO.	SIZE / DESCRIPTION	PKG QTY
<b>Wire Connectors</b>		
T1150	Small blue wire nut with spring insert	20
T1150C	Small blue wire nut with spring insert	100
T1151	Medium orange wire nut with spring insert	15
T1151C	Medium orange wire nut with spring insert	100
T1152	Large yellow wire nut with spring insert	15
T1152C	Large yellow wire nut with spring insert	100
T1153	Extra large red wire nut with spring insert	10
T1153C	Extra large red wire nut with spring insert	100
T1161C	Small yellow wire nut without insert	100



PART NO.	SIZE / DESCRIPTION	PKG QTY
<b>Line Tap with Disconnect</b>		
T1065	18-14 line taps only	10



PART NO.	SIZE / DESCRIPTION	PKG QTY
<b>Connectors and Adapters</b>		
T1124	.250 (1/4") female x #6 screw	10
T1124C	.250 (1/4") female x #6 screw	100



PART NO.	SIZE / DESCRIPTION	PKG QTY
<b>Closed End Connectors</b>		
T1056	22-18 insulated crimp type	20
T1056C	22-18 insulated crimp type	100
T1057	16-14 insulated crimp type	15
T1057C	16-14 insulated crimp type	100
T1058	12-10 insulated crimp type	15
T1058C	12-10 insulated crimp type	100
T1059	#8 insulated crimp type	15
T1059C	#8 insulated crimp type	100



PART NO.	SIZE / DESCRIPTION	PKG QTY
<b>Connectors and Adapters</b>		
T1123	.250 (1/4") x #10 stud	10
T1123C	.250 (1/4") x #10 stud	100

# Terminals & Connectors

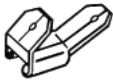

PART NO.	SIZE / DESCRIPTION	PKG QTY
<b>Connectors and Adapters</b>		
T1125	.250 (1/4") 2 male x 1 female	10



PART NO.	SIZE / DESCRIPTION	PKG QTY
<b>Connectors and Adapters</b>		
T1129	12-8 .250 (1/4") compressor terminal	10
T1129C	12-8 .250 (1/4") compressor terminal	100
T1130	16-14 .250 (1/4") compressor terminal	10



PART NO.	SIZE / DESCRIPTION	PKG QTY
<b>High Heat Porcelain Wire Connectors (Up To 1800 F)</b>		
T1164	Small #1 high heat porcelain wire nut 18 - 14 wire	15
T1164C	Small #1 high heat porcelain wire nut 18 - 14 wire	100
T1165	Small #3 high heat porcelain wire nut 12 - 10 wire	15
T1165C	Small #3 high heat porcelain wire nut 12 - 10 wire	100
T2070	Small #1 high heat porcelain wire nut 8 - 10 wire	10
T2070C	Small #7 high heat porcelain wire nut 8 - 10 wire	100



PART NO.	SIZE / DESCRIPTION	PKG QTY
<b>Alligator Clips</b>		
T1196	small includes black and red insulators	3 pair



PART NO.	SIZE / DESCRIPTION	PKG QTY
<b>Banana Plug</b>		
T1179	includes black and red insulators	1 pair



PART NO.	SIZE / DESCRIPTION	PKG QTY
<b>Heavy Duty Alligator Clips</b>		
T1186	small includes black and red insulators	1 pair
T1187	medium includes black and red insulators	1 pair



PART NO.	SIZE / DESCRIPTION	PKG QTY
<b>Scotchlok Electrical Spring Connectors</b>		
T1166	Small yellow	15
T1166C	Small yellow	100
T1167	Medium red	10
T1167C	Medium red	100
T1168	Large gray	5
T1168L	Large gray	50
T1169	Extra large blue	5
T1169L	Extra large blue	50



PART NO.	SIZE / DESCRIPTION	PKG QTY
<b>Alligator Clips</b>		
T1191	Small standard clips	10
T1192	Medium standard clips	5
T1193	Medium for use with test leads	5



12 per case

## M44 Aerosol Lubricant & Metal Protectant

Specially created and perfected for Professional technicians and mechanics everywhere... and there is nothing like it in the world!

- Turns old tools into new ones
- Can be used on cars, trucks, bicycles, fishing gear, marine gear, electrical and electronic gear, machinery, appliances etc.

### Applications

- Lubricates
- Prevents Rust and Corrosion
- Repels Moisture
- Restores Tools and Equipment



M098



M044

## M098 Zoom Spout® Oiler

A paraffin base, non-gumming, high quality lubricating oil

- All-Purpose Lubricating Oil
- Flexible spout extends and retracts, adjusts to any "in-between" length
- Withstands high temperatures without breaking down
- Viscosity 92-99 @ 140°F

### Applications

- All types of motors, blowers, oil burner bearings, linkages, appliance pumps, etc...
- Normal and High speed shaft bearings

## Rust Buster® Solvent

*Dissolves Rust*

- Telescoping Pullout Spout
- Loosens rust in seconds
- No lingering odor
- Counter Display Case

PART NO.	BOTTLE SIZE	PACKAGING
M098	4 oz	12/Case
M044	4 oz	12/Case



## SUPCO88 Oil Additive

Introduced in 1954 and valued worldwide, this super lubricant is a "must use" in repair and preventative maintenance programs.

- Compatible with all refrigeration oils
- Dissolves sludge buildup on bearing and valve surfaces
- Prevents binding of high speed compressors
- Prevents excess wear in motors and compressors

PART NO.	BOTTLE SIZE	PACKAGING
S8	8 OZ.	24/Case

### Application Notes:

To Prevent Excess Wear on Expansion Valves and Capillaries Mix one part SUPCO88 to 9 parts refrigeration oil.

- Prevents excess wear on expansion valve needles and seats.
- Penetrates the pores of ALL moving metal parts of the expansion valve for constant lubrication.

Extend the Life of ALL Motors (i.e. for Blowers and Air Conditioners)

- A few drops will help free a "frozen" or sticking motor shaft
- Mix 9 to one for regular bearing maintenance.
- Decreases "bearing to shaft" friction and sludge accumulation when mixed 9 to one.

More Efficiency for High Speed Compressors

- Increases the lubricating capability of mineral oils in high speed compressors.
- Used in new units to reduce current draw by reducing friction and preventing overloading.
- SUPCO88 can be left in the system permanently.



## S0100/ST200

### Slimeout®

## Condensate Pan Conditioning Tablets

- Slimeout® tablets prevent plugging of the air conditioning condensate drip pans and drain lines
- Slimeout® does not release any chlorine or other noxious fumes
- Slimeout® eliminates odors
- Slimeout® easily solves problems

	PART NO.	PART NO.
	S0100	ST200
Description	Slime Out	Slime Tab
Tablets Jar	100	200
Tablet Size	35 grams	20 grams
Initial Application	2 tabs/3 tons	3 tabs/3 tons
Maintenance	2 per month	3 per month

\* MSDS Sheets are available for all chemicals, visit [www.supco.com](http://www.supco.com)

# Chemicals



## Leak Lock and Leak Lock GOLD with Teflon

A resin based soft setting brushable paste pipe joint compound resistant to all refrigerants, oils, water and most chemicals, liquids and gases.

- Use with pressures to 10,000 PSI to full vacuums.
- Temperature range -200°F to 400°F, (-93°C) to (204°C).
- It never hardens and it never becomes brittle.
- Ideal for joining all metals, plastics and other materials.
- Will stick to all clean surfaces.
- GUARANTEES A PERFECT SEAL... UNDER ALL CONDITIONS
- Will stick to all clean surfaces.
- Prevent vibration from loosening nuts, bolts, plugs and fittings.
- Non Toxic



### Regular

PART NO.	SIZEPKG	
HS10001	1 1/3 oz Tube	12/Case
HS10004	4 oz Brush Top Plastic Jar	12/Case
HS10016	16 oz Brush Top Plastic Jar	12/Case
HS10128	1 Gallon Can	1

### Teflon

PART NO.	SIZEPKG	
HS11001	1 1/3 oz TUBE	12/Case
HS11004	4 oz Brush Top Plastic Jar	12/Case
HS11016	16 oz Brush Top Plastic Jar	12/Case
HS11128	1 Gallon Can	1

## Red Epoxy

When you need a sealant you can count on. High Performance, Heat Cured, Two Part, Epoxy Kit

- Exhibits a Color Change When Cured (Turns Gold)
- May Be Cured With a Hot Air Gun or Open Flame in Minutes
- -100°F to 300°F, (-73°C to 149°C)
- Working Pressure in Excess of 3000 PSI
- Tensile Strength: 6000 PSI
- Works on Vertical Surfaces
- Pressure Tested to 3000 PSI
- Simple, Quick Mixing & Application
- Oil, Gas, Fuel & Solvent Resistant
- No Rush, No Wait, You Control Curing Time
- Equipment is Serviceable Immediately
- Use on All Metals and Rigid Plastics
- HVAC & Refrigeration
- Plumbing & Appliances
- Automotive & Marine
- Petrochemical, Manufacturing
- Industrial, Commercial, Institutional



PART NO.	SIZE	PKG
HS12001	Kit Including 2 1/2 oz Tubes	12/Case

## Solderlene

High Quality, Paste Type, Non-Acid Soldering Flux.

- Industrial strength wetting agents to promote solder flow
- For use with low and mid-temp. soft solders, both lead and lead-free
- Effective on all metals except aluminum and magnesium.
- Brush Top Plastic Jars



PART NO.	SIZE	PKG
HS30004	4 oz	12/Case
HS30016	16 oz	12/Case

## Thawzone (New Formula)

The original liquid dehydrant, frees your frozen system in minutes. It seeks out moisture and chemically bonds to it.

- Enhanced moisture control in even the most advanced systems.
- Aids with oil return in low temperature systems.
- Compatible with all refrigerants and refrigeration lubricants.
- Helps prevent the formation of acid.
- No Methanol
- Environmentally Sound

- Safer
- Biodegradable, non-polluting
- Non-Poisonous

PART NO.	SIZE	PKG
HS17001	1 oz	24/Case
HS17004	4 oz	12/Case
HS17016	16 oz	6/Case

Add 1/8 fluid ounce ( 3.75 ml ) of THAWZONE directly to the refrigerant of any system for every 1 lb. of refrigerant in the system.

\*HIGHSIDE SYSTEM INJECTOR (part no. HSINJ001) IS RECOMMENDED FOR INTRODUCING THAWZONE INTO AN OPERATING SYSTEM.



## Spiro Lite UV Bulb

120 Volt Florescent UV Light Source  
For Your Light Trouble

PART NO.	PKG
HSUVB001	1



\* MSDS Sheets are available for all chemicals, visit [www.supco.com](http://www.supco.com)



## Highside System Injector

Use for introducing any liquid into the low side of a charged hermetic system.

- Entirely reusable
- Constructed of rugged aluminum for long life
- Designed for use with any standard manifold gauge and requires no extra valves or fittings
- Drip proof, no spill design takes the mess out of maintenance
- Helps prevent the venting of refrigerants into the atmosphere.
- Prevents the introduction of air into an operating system.
- It can be used on sealed operating systems to avoid shutdowns.
- Use with Trace, Trace 2, Thawzone and Acid Neutralizer
- Compatible with all refrigerants

PART NO.	PKG
HSINJ001	1



## Gas Leak Detector Low Temp

Leaks appear as large strong bubbles which cling to the surface and are fluorescent under a black light.

- Non-freezing
- Fluorescent
- Rated to -30°F (-34°C)
- Non-toxic
- Non-hazardous
- Bubble-type gas leak detector

### Use On:

- Hot and cold piping
- Natural Gas
- Most Gases
- Air
- All Refrigerants

PART NO.	SIZE	TYPE	PKG
<b>LOW TEMP</b>			
HS22008	8 oz	Plastic Bottle w/Dauber	24/Case
HS22032	32 oz	Trigger Sprayer Bottle	12/Case
HS22128	1 Gal.	Plastic Bottle	6/Case
<b>MID TEMP</b>			
HS23008	8 oz	Plastic bottle w/Dauber	24/Case
HS23032	32 oz	Trigger Sprayer Bottle	12/Case
HS23128	1 Gal.	Plastic Bottle	6/Case

## Gas Leak Detector Mid Temp

Same as above except:

- Rated to 27°F (-3°C)



## Trace2

A red penetrant dye in a polyolester base that is completely compatible with all refrigerants and lubricants, old and new. Use to locate the hardest to find leaks under the toughest conditions in low light or dark areas.

- Leaks show as bright red stains
- For refrigeration and hydraulic systems
- Florescent with any ultraviolet light source
- Non-volatile and will not sludge or deposit gum
- Clearly visible, even through ice and frost
- Locates leaks exactly, no false positives

## Trace

A red penetrant dye in a mineral oil base that is completely harmless to refrigeration, air conditioning and hydraulic equipment.



## Hydro Trace

Locate hard-to-find leaks in any closed system containing water and/or antifreeze compounds such as Propylene Glycol and Ethylene Glycol. When added to a system leaks are easily visible as bright red stains under normal lighting conditions and as a bright orange glow when exposed to an ultraviolet light source.

### Applications Include:

- Refrigeration
- Hydronics
- Automotive
- Process Cooling
- Chemically Inert
- Will not harm equipment or seals

WITH SUPERBRITE UV TRACER		
PART NO.	SIZE	PKG
<b>TRACE2</b>		
HS21004	4 oz Plastic Bottle	12/Case
HS21016	16 oz Plastic Bottle	6/Case
HS21128	1 Gallon Can	4/Case
<b>TRACE</b>		
HS20004	4 oz Plastic Bottle	12/Case
HS20016	16 oz Plastic Bottle	6/Case
HS20128	1 Gallon Can	4/Case
<b>HYDRO TRACE</b>		
HS26004	4 oz Plastic Bottle	12/Case
HS26016	16 oz Plastic Bottle	6/Case
HS26128	1 Gallon Can	4/Case

Trace2 and Trace are the easiest and least expensive way to locate leaks in an operating system and are for use in systems where the lubricants travel with refrigerants.

# Chemicals



## Trax

Bubble-type liquid leak detector formulated to produce long lasting bubbles under 'job-site' conditions.

- Clear
- No Cleanup
- Environmentally Friendly
- Evaporates Leaving No Residue
- Temp Range: 27°F to 200°F (-3°C to 93°C).

- Non-Toxic
- Does Not Pit Surfaces
- Detects Leaks as Small as 1 Micron
- Oxygen Compatible

Meets the performance requirements of Military specifications: MIL 25567 Type I A, B & C.

PART NO.	SIZE	TYPE	PKG
HS24000	1 1/3 oz	Squeeze Bottle	24/Case
HS24010	10 oz	Squeeze Bottle w/ Extensible Spout	12/Case
HS24128	1 GAL.	Bottle	6/Case



## Dye Wash

Removes any type of leak detecting dye from equipment and Pipe surfaces to prevent false readings during future and follow-up leak detection.

- Non-Toxic
- Environmentally Friendly
- Non-Corrosive
- Easy To Use

PART NO.	SIZE	PKG
HS51032	32 oz Spray Bottle	12/Case

## Oil Checker

Highside Chemicals introduces the newest chemical tool for easily identifying all refrigeration, air conditioning and heat pump lubricants in just seconds.



### Features/Benefits

- Easy to use two step process that identifies all types of oils.
- Test results within seconds
- Each kit includes two complete tests.
- Should be used to check the type of oil in a system before adding any additional oil.
- Compatible with Mineral, Alkybenzene and Polyolester type oils.
- Saves time and money by eliminating the need for a refractometer or expensive laboratory tests.
- Avoids the costly mistake of mixing POE and Mineral refrigeration oils.

PART NO.	PKG
HS16501	12/Case

## The Acid Test - 4 COMPLETE TESTS IN EACH KIT

For detecting the presence and formation of acid in air conditioning and refrigeration systems.

- Easy to use
- No Complicated Charts
- Results in Seconds
- Very Inexpensive
- Non-Toxic
- Non-Hazardous
- Accurate Results
- Eliminates Guess Work
- Safe Formula
- Biodegradable
- Non-Flammable
- For use with all Refrigerants

PART NO.	PKG
HS16001	12/Case

### Simple to Understand Color Change Indicators!

- BLUE OR VIOLET . No Acid Present
- GREEN..... Moderately Acidic
- YELLOW ..... Acidic



## Acid Neutralizer

The BEST Acid Treatment available neutralizes residual acid caused by compressor burnout. *The Cure for Acid Problems.*

- Works Fast
- Circulates Quickly
- Compatible with ALL Lubricants
- Safe, Will Not Harm System Components
- No Complicated Charts
- No Solids or Solid Residuals
- Compatible with ALL Refrigerants
- Neutralizes Acid in Recovery Equipment
- Easy to Use
- Can Prevent Compressor Burnout

A vital part of any preventative maintenance program.

PART NO.	SIZE	PKG
HS18004	4 oz.	12/Case



\* MSDS Sheets are available for all chemicals, visit [www.supco.com](http://www.supco.com)



## Super Flush AC/R Internal System Cleaner

Neutralizes and Removes Acid Caused By Compressor Burnout

- Biodegradable
- Easy to Use
- Cleans in a Single Treatment
- Compatible with All Refrigerants and Refrigeration Oils
- Does Not Contain Halogenated Solvents
- Cleaning Agent for all A/C and Refrigeration Parts
- Environmentally Safe
- Non-Flammable
- Saves Time and Money

### One Treatment Cleans and Removes:

- Sludge
- Gum
- Debris
- Moisture
- Carbon Deposits
- Tar
- Grease
- Organic Acids
- Soot
- Mineral Acids

### Use:

- Before a system retrofit
- After a compressor burnout
- Recovery, Recycling and Reclamation Equipment
- On automotive (Remove immediately)



PART NO.	SIZE	PKG
HS55032	32 oz Plastic Bottle	12/Case
HS55128	1 Gal. Plastic Bottle	6/Case

## Coil Tamer Products Made For The Professionals

### PINK STUFF

Heavy Duty, Foaming, Acid Based Concentrated Liquid Coil Cleaner Foaming Action Pushes Dirt Out of Coils to be Rinsed Away.

- Non Flammable
- Easy to Use
- Non Oily
- Biodegradable

### Cleans and Brightens:

- Condenser Coils
- Evaporator Coils
- Equipment Surfaces

### Effective On:

- Heavy Oxidation
- Mold
- Lint
- Oily Dirt
- Algae
- Mildew
- Grease
- Oils

Easily Applied Using Standard Low Pressure Sprayer

PART NO.	SIZE	PKG
HS58128	1 Gal. Plastic Bottle	4/Case



### GREEN STUFF

Concentrated Alkaline Based Liquid Coil Cleaner

- Non Flammable
- Fast Acting
- Non Oily
- Biodegradable
- Brightens

### For Heavy Duty Cleaning and Degreasing of:

- Condenser Coils
- Permanent Filters
- Evaporator Coils
- Equipment Surfaces
- Fins
- Electronic Cells

### Effective On:

- Grease
- Lint
- Tar
- Mold
- Dirt
- Mildew
- Oil
- Dust
- Algae
- Nicotine

Self Rinsing on Evaporator Coils and is Easily Applied with a Low Pressure Sprayer.

PART NO.	SIZE	PKG
HS59128	1 Gal. Plastic Bottle	4/Case



### EV Coil Max

Powerful Coil Cleaner in Powder Form to Avoid Dangerous Liquid Spills.

- Environmentally Friendly
- Virtually Odorless
- Easy to Use and Clean Up
- Lowers Freight Costs
- Extra Long Shelf Life
- Its powder form is a safer alternative to liquid coil cleaners
- No Acidic Residue
- Fast Acting
- Prevents Corrosion
- Less Storage Space

\*16 oz equals 1 gallon 6:1 (9 lbs or 144oz weight) solution

PART NO.	SIZE	PKG
HS56011	16 oz Plastic Jar	12/Case



### HL Coil Brite Coil Cleaner

Acid Based, Powder Coil Cleaner with Controlled Foaming Action

- Clean the Toughest Coils
- Mild Odor
- Indefinite Shelf Life
- Nonflammable
- Lowers Freight Costs
- Less Storage Space
- Easy to Use
- No Dangerous Liquid Spills
- Makes Old Coils Look New
- Easy Rinse for Quick Cleaning

\*14oz equals 1 gallon 6:1 (9 lbs or 144oz weight) solution

PART NO.	SIZE	PKG
HS57014	14 oz Plastic Bottle	12/Case



# Chemicals



## Coil Blaster Solvent

Solvent Based High Pressure Aerosol Coil Cleaner

- Pleasantly Scented
- Nonflammable
- Degreases
- Fast Drying
- Nonconductive
- Safe To Use On Equipment While Running

### Use On:

- Evaporator Coils
- Electrical Equipment
- Condenser Coils
- Automotive Parts

### Effective On:

- Dirt
- Grime
- Grease
- Oil

- Basting Aerosol Nozzle
- No Residue
- Easy To Use
- No Cleanup

- All HVAC/R Equipment
- Electrical Components

PART NO.	SIZE	PKG
HS58520	18 oz Aerosol Can	12/Case



## HD Jet Foamer Coil Cleaner

Heavy Duty Foaming Coil Cleaner in an aerosol can

- Convenient
- Pleasant Scent
- Environmentally Friendly
- No Ozone Depleters
- 360
- No Chlorinated Solvents
- Easy to Store
- Water Based
- Nonflammable
- Corrosion Inhibitors
- Spray Nozzle

### Quickly and Easily Liquifies:

- Dirt
- Oil
- Deposits
- Grease
- Residues

### Use On:

- Evaporator Coils
- Condenser Coils

Will Not Harm Plastics, Metals or Surrounding Equipment

PART NO.	SIZE	PKG
HS59520	19 oz Aerosol Can	12/Case



## ICEMAX Nickel Safe Ice Machine Cleaner

High Performance Ice Machine Cleaner in a Powder avoids dangerous and messy spills that can damage your facility, vehicles and destroy other valuable inventory. Prevents liquid spills that can attract unnecessary regulatory attention.

- Inhibits Formation of Scale
- Prevents Corrosion
- Environmentally Friendly
- Will Not Separate or Chemically Change Over Time
- Indefinite Shelf Life (When Kept Sealed)
- Saves Freight Costs
- Maximum Scale Removing Power
- No Acidic Residue
- Makes 1 Gallon of Concentrated Cleaner

PART NO.	SIZE	PKG
HS50004	4.4 oz	12/Case



## Filter Fan & Vent Cleaner

Heavy duty cleaner specifically formulated for the heating, ventilation, air-conditioning and refrigeration industry.

- Biodegradable
- Non-Corrosive
- Easy to Use
- Environmentally Friendly
- Non-Toxic
- Safe & Effective

### Removes:

- Dust
- Grease
- Tar Deposits
- Dirt
- Oil

### Use On:

- Electronic Cells
- Permanent Air Filters
- All Vents & Vent Surfaces
- Equipment Surfaces
- Most Air Cleaning Equipment
- Permanent Pre-Filters
- Fan Blades, Plastic & Metal

PART NO.	SIZE	PKG
HS52032	32oz Plastic Spray Bottle	12/Case
HS52128	1 Gal. Plastic Refill	6/Case

## CDC Anti-Clog

Condensate Drainpan Conditioner

Laboratory proven to kill 99% of Legionnaire's Disease bacteria and a broad spectrum of harmful bacteria including those causing the common cold and other respiratory ailments.

- EPA Registered
- Improved Chemical Formulation
- Water activated timed-release
- 3 to 6 months, 24 hours/day service
- Works in equipment of all sizes (Available in 2 Sizes)
- Filter material meters biocide for consistent chemical release
- Sealed, tamper proof housing prevents skin contact w/ biocide
- Designed not to clog drain hole
- Can be placed vertically or horizontally
- Ph neutralizers help protect drainpan against corrosion
- 40% more high efficiency biocide (by weight)

Use CDC ANTI-CLOG\* wherever there is Air Conditioning and Refrigeration Equipment

PART NO.	SIZE	PKG
HS52105	Units up to 5 Tons	24/Case
HS52115	Units up to 15 Tons	12/Case



\* MSDS Sheets are available for all chemicals, visit [www.supco.com](http://www.supco.com)



## ICE BLOCK Heat Transfer & Anti-Freeze

Propylene Glycol based anti-freeze and heat transfer fluid capable of providing pipe burst protection to temperatures as low as -100°F (-73°C). All ingredients are generally regarded as safe by the FDA, making ICE BLOCK the recommended anti-freeze protection where there is possible contact with potable water sources.

- Non-Toxic
- Chemically Stable - Will Not Separate
- Maximum Heat Transfer
- Protects Pipes and Other System Components From Freeze Damage
- Safe and Easy to Use
- Lubricates As It Works
- Safe For Use Where Contact with Potable Water is Possible
- Maximum Corrosion Protection
- Will Not Leave Deposits

### Applications Include:

- Refrigeration Systems
- Chilled Water Systems
- Coil Defrosting
- Ice Making Machines
- Water Based Heat Extraction System
- Snow Melting Systems
- Winterization of Any Water Based Systems
- Hydronic Heating Systems
- Solar Heating & Hot Water Systems
- Cooling Systems & Chillers
- Immersion Freezing
- Air Hydronic, Heat Pumps & Furnaces.
- Process Cooling
- Ground Water Coupled Heat Pumps
- Cooling Towers
- Industrial Heat Transfer Systems
- Fire Hydrant & Sprinkler System

PART NO.	SIZE	PKG
HS15128	1 Gallon	6/Case



## KLEEN-AIR Odor Absorber

- Simply open the spout to absorb and remove all kinds of odors.
- One 8 ounce bottle works for 1 year in a 9' x 12' room

PART NO.	SIZE	PKG
KA12	8 oz.	12/Case



## Epoxy Putty

- Cures Wet or Dry - will cure underwater
- Mixes like clay hardens like steel
- After curing, can be sanded, drilled tapped, machined, sawn, or painted.
- Initial set in 10 to 15 minutes, hard set 1 hour, with full cure in 24 hours.
- Temperature range -65°F to +250°F
- Works on glass, wood, plastic, fiberglass, tile, concrete, and many more.

PART NO.	DESCRIPTION	QUANTITY PER CARTON	REPLACES GEM NO.
9900H	Tan Epoxy Putty 4" blocks	24	—
9904H	White Epoxy Putty 4" blocks	24	EP8002 Half-size
9904K	White Epoxy Putty 8" blocks	24	EP8002
9906H	Aluminum Epoxy Putty 4" blocks	24	EP8001 Half-size
9906K	Aluminum Epoxy Putty 8" blocks	24	EP8001
9915K	White Fast Set Epoxy Paste	24	—

## English Conversion Factors & Data

### To Convert Measurements

From	To	Multiply By
Cubic Feet	Cubic Inches	1728.
Cubic Inches	Cubic Feet	0.00058
Cubic Feet	Gallons	7.480
Gallons	Cubic Feet	0.1337
Cubic Inches	Gallons	0.00433
Gallons	Cubic Inches	231.
Barrels	Gallons	42.
Gallons	Barrels	0.0238
Imperial Gallons	U.S. Gallons	1.2009
U.S. Gallons	Imperial Gallons	0.8326
Feet	Inches	12.
Inches	Feet	0.0833
Square Feet	Square Inches	144.
Square Inches	Square Feet	0.00695
Short Tons	Pounds	2000.
Liters	U.S. Gallons	0.2642

### To Convert Pressure (at 32° F)

From	To	Multiply By
Inches of Water	Pounds per Sq. Inch	0.03612
Pounds per Sq. Inch	Inches of Water	27.686
Feet of Water	Pounds o Sq. Inch	0.4334
Pounds per Sq. Inch	Feet of Water	2.307
Inches of Mercury	Pounds per Sq. Inch	0.4912
Pounds per Sq. Inch	Inches of Mercury	2.036
Atmospheres	Pounds per Sq. Inch	14.696
Pounds per Sq. Inch	Atmospheres	0.06804

### To Convert Power

From	To	Multiply By
Horsepower	Metric Horsepower	1.014
Horsepower	Ft./Power per Minute	33000.
Horsepower	Kilowatts	0.746
Kilowatts	Horsepower	1.3404
British Thermal Units	Foot/Pounds	778.177
Foot/Pounds	British Thermal Units	0.001285
British Thermal Units	Horsepower Hours	0.0003927
Horsepower Hours	British Thermal Units	2544.1
British Thermal Units	Kilowatt Hours	0.0002928
Kilowatt Hours	British Thermal Units	3415.
Watt Hours	British Thermal Units	3.415

### Volume-Weight Conversions

	wt. lbs.
1 Cubic Foot of Water.....	62.4*
1 Cubic Inch of Water.....	0.0361*
1 Gallon of Water.....	8.33*
1 Cubic Foot of Air.....	.075+
1 Cubic Inch of Steel.....	0.284
1 Cubic Foot of Brick (Building).....	112-120
1 Cubic Foot of Concrete.....	120-140
1 Cubic Foot of Earth.....	70-120

\* at 32° F

+ at 70° F. -29.92" Hg.

## English to Metric Conversion Factors

### To Convert Measurements

From	To	Multiply By
Cubic Feet	Cubic Centimeters	28317.0
Cubic Inches	Cubic Centimeters	16.387
Cubic Feet	Liters	28.32
Gallons	Liters	3.7854
Cubic Inches	Liters	0.0164
Gallons	Cubic Centimeters	3785.4
Barrels	Cubic Meters	1.0551
Imperial Gallons	Cubic Meters	0.0045461
U.S. Gallons	Cubic Meters	0.0037854
Feet	Meters	0.3048
Inches	Meters	0.0254
Square Feet	Square Meters	0.0929
Square Inches	Square Centimeters	6.452
Ton (Short, 2000 lb.)	Kilograms	907.2
Liter	Cubic Meters	0.001
Pounds	Kilograms	0.45359

### To Convert Pressure (at 32° F)

From	To	Multiply By
Inches of Water	Newton/Sq. Meter	249.082
Pounds per Sq. Inch	Newton/Sq. Meter	6894.8
Feet of Water	Newton/Sq. Meter	2988.98
Pounds per Sq. Inch	Kilograms/Sq. Cent	0.07031
Inches of Mercury	Newton/Sq. Meter	3386.4
Pounds per Sq. Inch	Dyne/Sq. Cent.	68948.0
Atmospheres	Newton/Sq. Meter	101325.0
Pascal	Newton/Sq. Meter	1.0

### To Convert Energy, Heat and Power

From	To	Multiply By
Horsepower	Watt	745.7
British Thermal Units	Joule	1054.35
Foot-Pounds	Joule	1.3558
British Thermal Units	Calorie	252.0
British Thermal Units	Watt-Second	1054.35
Watt-Second	Joule	1.0
Calorie	Joule	4.184
Watt-Hours	Joule	3600.0
Kilocalorie/Minute	Watt	69.73
Ton (Refrigeration)	Watt	3516.8
BTU/Hour	Watt	0.29288
BTU/In/Hr. Ft. (2) ° F	Watt/Meter K	0.14413
BTU/Hr. at 10° F TD	Kcal/Hr. at 6° C. TD	0.252
BTU/Hr. at 15° F TD	Kcal/Hr. at 8° C. TD	0.252

### Volume-Weight Conversions

	Wt. Kilograms
1 Cubic Foot of Water.....	28.3*
1 Cubic Inch of Water.....	0.0164*
1 Gallon of Water.....	3.788
1 Cubic Foot of Air.....	0.034+
1 Cubic Inch of Steel.....	0.1288
1 Cubic Foot of Brick (Building).....	51-54
1 Cubic Foot of Concrete.....	54-64
1 Cubic Foot of Earth.....	32-54

\* at 32° F

+ at 70° F. -29.92" Hg.

## Single Phase Heating Element Conversion Chart

240 Volts	208 Volts	120 Volts
6000 Watts	4500 Watts	1500 Watts
5000 Watts	3750 Watts	1250 Watts
4000 Watts	3000 Watts	1000 Watts
3000 Watts	2250 Watts	750 Watts
2500 Watts	1875 Watts	625 Watts
2000 Watts	1500 Watts	500 Watts

Always use a higher voltage element to replace a lower voltage element

To calculate the wattage at a lower voltage see formula's below.

Convert 480V to 240V, Multiply wattage at 480V times 25%.

Convert 240V to 208V, Multiply wattage at 240V times 75%.

Convert 240V to 120V, Multiply wattage at 240V times 25%.

Convert 208V to 120V, Multiply wattage at 208V times 33%.

For use in single phase 60hz. applications only.

### Ohms Law Wheel



This chart shows four ways to figure each value:

Amps (I), Volts (E), Ohms (R), or Watts (W)

#### Example:

A 4800 watt electric heat element is connected to a 240 volt circuit. How many Amps (I) does it draw?

#### Solution:

Locate Amps section of chart-  
 $\frac{\text{Watts (W)}}{\text{Volts (E)}} = \text{Amps (I)}$

Thus  $4800 / 240 = 20$  Amps. Carried further, what is the resistance?

$\frac{\text{Volts}^2 (E^2)}{\text{Watts (W)}} = \text{Ohms (R)}$   $240 \times 240 / 4800 = 12$  Ohms

### Horse Power - Ampre Table

Approximate Horsepower		120 Volts		240 Volts	
		Full Load	Locked Rotor	Full Load	Locked Rotor
1/4	AC	4.4	26.4	2.2	13.2
	DC	—	—	—	—
1/4	AC	5.8	34.8	2.9	17.4
	DC	2.9	29.0	1.5	15.0
1/3	AC	7.2	43.2	3.6	21.6
	DC	3.6	36.0	1.8	18.0
1/2	AC	9.8	58.8	4.9	29.4
	DC	5.2	52.0	2.6	26.0
3/4	AC	13.8	82.8	6.9	41.4
	DC	7.4	74.0	3.7	37.0
1	AC	16.0	96.0	8.0	48.0
	DC	9.4	94.0	4.7	47.0
1 1/2	AC	20.0	120.0	10.0	60.0
	DC	13.2	132.0	6.6	66.0
2	AC	24.0	144.0	12.0	72.0
	DC	17.0	170.0	8.5	85.0
3	AC	34.0	204.0	17.0	102.0
	DC	25.0	250.0	12.2	122.0
5	AC	56.0	366.0	28.0	168.0
	DC	—	—	20.0	200.0
7 1/2	AC	80.0	480.0	40.0	240.0
	DC	—	—	29.0	290.0

\* Locked rotor ratings shown are 6 times full load on AC and 10 time full load on DC. The above chart is offered as a guide only, as all motors do not necessarily come within the maximum ratings shown in the chart.

Thermal Units		
Latent heat of ice	= 144 BTU/lb	= 288,000 BTU/ton
1 ton refrigeration	= 12,000 BTU/hr	= 288,000/24 hours
1 British Thermal Unit (BTU)		= .252 kcal
1 kilo - calorie (kcal)		= 3.97 BTU
1 BTU/lb		= 0.555 kcal/kg
1 watt		= 1.8 BTU/lb
		= 1 kcal/kg/°C.
		= 3.413 BTU/hr
Heat, Energy, Work		
1 ft lb	= .001285 BTU	= 0.13826 kg-meter
1 joule	= 1 watt - second	= .000948 BTU
1 BTU	= 778.1 ft lb	= .252 kcal
1 KCAL	= 3,968 BTU	= 1000 cal
1 hp-hr	= .746 kw-hr	= 2544.7 BTU
1 kw-hr	= 1,341 hp-hr	= 3413 BTU
1 boiler horsepower	= 33479 BTU/hr	= Evaporation of 34.5 water/hr at 212° F.

## Approximate Temperature Guide

Application	Average Temperature	Difference Between Coil and Room
Wet produce walk-in	40°	10°
Dry produce walk-in	40°	13°
Produce cases	40°	18°
Mortuary vaults - Blower coil	32° to 35°	18°
Enclosed service meat case	35°	15°
Open shelf service meat case	29°	25°
Dairy case	35° to 38°	25°
Freezer cases - General	-5° to -10°	10°
Ice cream - Holding	-15°	10°
Ice cream - Dipping		
Vanilla	8°	10°
Chocolate	6°	10°
Fruit	4°	10°
Soda fountains - Fruits and syrup	35° to 38°	10°
Air conditioning	75°	40°
Fruit boxes	50° to 55°	20°
Water chillers - Air conditioning	45°	10°
Water coolers - Drinking	38° to 50°	10°
Refrigerators	35°	20°
Biscuit cases	35°	20°
Milk coolers	40°	10°
Work rooms	35° to 50°	10° to 20°

## Temperature Conversion Chart

Fahrenheit	Celsius	Fahrenheit	Celsius
500	260.0	150	65.6
475	246.1	145	62.8
450	232.2	140	60.0
425	218.3	135	57.2
400	204.4	130	54.4
390	198.8	125	51.7
380	193.3	120	48.9
370	187.8	115	46.1
360	182.2	110	43.3
350	176.7	105	40.6
340	171.1	100	37.8
330	165.6	95	35.0
320	160.0	90	32.2
310	154.4	85	29.4
300	148.9	80	26.7
290	143.3	75	23.9
280	137.8	70	21.1
270	132.2	65	18.3
260	126.7	60	15.6
250	121.1	55	12.8
245	118.3	50	10.0
240	115.6	45	7.2
235	112.8	40	4.4
230	110.0	35	1.7
225	107.2	32	0.0
220	104.4	30	-1.1
215	101.7	25	-3.9
212	100.0	20	-6.7
210	98.9	15	-9.4
205	96.1	10	-12.2
200	93.3	5	-15.0
195	90.6	0	-17.8
190	87.8	-5	-20.6
185	85.0	-10	-23.3
180	82.2	-15	-26.1
175	79.4	-20	-28.9
170	76.7	-25	-31.7
165	73.9	-30	-34.4
160	71.1	-35	-37.2
155	68.3	-40	-40.0

Conversion Factors:

Fahrenheit to Celsius: Degrees Fahrenheit minus 32 x 5/9 (0.556)

Celsius to Fahrenheit: Degrees Celsius times 9/5 (1.8) plus 32

## Decimal Equivalents

Inch Fraction	Inch Decimal	Millimeters
1/16	0.0625	1.588
5/64	0.07812	1.984
3/32	0.09375	2.381
7/64	0.10937	2.778
1/8	0.1250	3.175
9/64	0.14062	3.572
5/32	0.15625	3.969
11/64	0.17187	4.366
3/16	0.1875	4.763
13/64	0.20312	5.159
7/32	0.21875	5.556
15/64	0.23437	5.953
1/4	0.2500	6.350
17/64	0.26562	6.747
9/32	0.28125	7.144
19/64	0.29687	7.541
5/16	0.3125	7.938
21/64	0.32812	8.334
11/32	0.34375	8.731
23/64	0.35937	9.128
3/8	0.3750	9.525
25/64	0.39062	9.922
13/32	0.40625	10.319
27/64	0.42187	10.716
7/16	0.4375	11.113
29/64	0.45312	11.509
15/32	0.46875	11.906
31/64	0.48437	12.303
1/2	0.5	12.700
33/64	0.51652	13.097
17/32	0.53125	13.494
35/64	0.54687	13.891
9/16	0.5625	14.288
37/64	0.57812	14.684
19/32	0.59375	15.081
39/64	0.60937	15.478
5/8	0.625	15.875
41/64	0.64062	16.272
21/32	0.65625	16.669
43/64	0.67187	17.066
11/16	0.6875	17.463
45/64	0.70312	17.859
23/32	0.71875	18.256
47/64	0.73437	18.653
3/4	0.750	19.050
49/64	0.76562	19.447
25/32	0.78125	19.844
51/64	0.79687	20.241
13/16	0.8125	20.638
53/64	0.82812	21.034
27/32	0.84375	21.431
55/64	0.85937	21.828
7/8	0.875	22.225
57/64	0.89062	22.622
29/32	0.90625	23.019
59/64	0.92187	23.416
15/16	0.9375	23.813
61/64	0.95312	24.209
31/32	0.96875	24.606
63/64	0.98437	25.003
	1.000	25.400

# Refrigerant Temperature Pressure Chart

□ Figures = Vacuum

Black Figures = Vapor (PSIG)

**Bold Figures = Liquid (PSIG)**

°F	R-12	R-134a	R-401A	R-409A	R-22	R-410A	R-502	R-404A	R-507	R-402A	R-408A	R-717
-50	15.4	18.4	18.5	—	6.2	5.8	0.2	0.0	0.9	1.2	2.4	14.3
-48	14.6	17.7	17.7	—	4.8	6.9	0.7	0.8	1.7	2.1	1.0	13.1
-46	13.8	17.0	17.0	—	3.4	8.0	1.5	1.6	2.6	2.9	.3	12.1
-44	12.9	16.2	16.0	—	2.0	9.2	2.3	2.5	3.5	3.9	1.1	11.0
-42	11.9	15.4	15.0	—	0.5	10.4	3.2	3.4	4.5	4.9	1.9	9.9
-40	11.0	14.5	14.5	—	0.5	11.7	4.1	5.5	5.5	5.9	2.8	8.7
-38	10.0	13.7	13.5	—	1.3	13.0	5.0	6.5	6.5	6.9	3.7	7.4
-36	8.9	12.8	12.5	—	2.2	14.4	6.0	7.5	7.6	8.0	4.6	6.1
-34	7.8	11.8	11.5	—	3.0	15.9	7.0	8.6	8.7	9.2	5.6	4.7
-32	6.7	10.8	10.6	—	4.0	17.3	8.1	9.7	9.9	10.3	6.6	3.2
-30	5.5	9.7	9.0	—	4.9	18.9	9.2	10.8	11.1	11.6	7.6	1.6
-28	4.3	8.6	8.3	—	5.9	20.5	10.3	12.0	12.4	12.8	8.7	0.0
-26	3.0	7.7	7.0	—	6.9	22.2	11.5	13.2	13.7	14.1	9.8	0.6
-24	1.6	6.2	6.0	—	7.9	23.9	12.7	14.5	15.0	15.5	11.0	1.7
-22	0.3	4.9	4.5	—	9.0	25.7	14.0	15.8	16.4	16.9	12.2	2.6
-20	0.6	3.6	3.5	—	1.9	10.1	27.5	15.3	17.1	17.8	18.4	3.6
-18	1.3	2.3	2.0	—	5	11.3	29.4	16.7	18.5	19.3	19.9	4.6
-16	2.1	0.8	0.5	—	.5	12.5	31.4	18.1	20.0	20.9	21.5	5.6
-14	2.8	0.3	0.4	—	1.2	13.8	33.5	19.5	21.5	22.5	23.1	6.7
-12	3.7	1.1	1.4	—	2.0	15.1	35.6	21.0	23.0	24.1	24.8	7.9
-10	4.5	1.9	2.2	—	2.8	16.5	37.8	22.6	24.6	25.8	26.5	9.0
-8	5.4	2.8	3.1	—	3.6	17.9	40.0	24.2	26.3	27.6	28.3	10.3
-6	6.3	3.6	3.9	—	4.4	19.3	42.4	25.8	28.0	29.4	30.2	11.6
-4	7.2	4.5	4.8	—	5.3	20.8	44.8	27.5	29.8	31.3	32.1	12.9
-2	8.2	5.5	5.7	—	6.2	22.4	47.3	29.3	31.6	33.2	34.1	14.3
0	9.2	6.5	6.7	—	7.2	24.0	49.8	31.1	33.5	35.2	36.1	15.7
2	10.2	7.5	8.0	—	8.2	25.6	52.5	32.9	34.8	37.3	38.1	17.2
4	11.2	8.5	8.8	—	9.2	27.3	55.2	34.9	37.4	39.4	40.4	18.8
6	12.3	9.6	9.9	—	10.2	29.1	58.0	36.9	39.4	41.6	42.6	20.4
8	13.5	10.8	11.0	—	11.3	30.9	60.9	38.9	41.6	43.8	44.9	22.1
10	14.6	12.0	12.2	—	12.5	32.8	63.9	41.0	43.7	46.2	47.3	23.8
12	15.8	13.1	13.4	—	13.6	34.7	67.0	43.2	46.0	48.5	49.7	25.6
14	17.1	14.4	14.6	—	14.8	36.7	70.2	45.4	48.3	51.0	52.5	27.5
16	18.4	15.7	15.9	—	16.1	38.7	73.4	47.7	50.7	53.5	54.8	29.4
18	19.7	17.0	17.2	—	17.4	40.9	76.8	50.0	53.1	56.1	57.5	31.4
20	21.0	18.4	18.6	—	18.7	43.0	80.2	52.5	55.6	58.8	60.2	33.5
22	22.4	19.9	20.0	—	20.0	45.3	83.8	54.9	58.2	61.5	63.0	35.7
24	23.9	21.4	21.5	—	21.5	47.6	87.4	57.5	60.9	64.3	65.9	37.9
26	25.4	22.9	23.0	—	22.9	49.9	91.2	60.1	63.6	67.2	68.9	40.2
28	26.9	24.5	24.6	—	24.4	52.4	95.1	62.8	66.5	70.2	72.0	42.6
30	28.5	26.1	26.2	—	26.0	54.9	99.0	65.6	69.4	73.3	75.1	45.0
32	30.1	27.8	27.9	—	27.6	57.5	103.1	68.4	72.3	76.4	78.3	47.6
34	31.7	29.5	29.6	—	29.2	60.1	107.3	71.3	75.4	79.6	81.6	50.2
36	33.4	31.3	31.3	—	30.9	62.8	111.6	74.3	78.5	82.9	85.0	52.9
38	35.2	33.2	33.2	—	32.7	65.6	116.0	77.4	81.8	86.3	88.5	55.7
40	36.9	35.1	35.0	—	34.5	68.5	120.5	80.5	85.1	89.8	92.1	58.6
42	38.8	37.0	37.0	—	36.3	71.5	125.1	83.8	88.5	93.4	95.7	61.6
44	40.7	39.1	39.0	—	38.2	74.5	129.9	87.0	91.9	97.0	99.5	64.5
46	42.7	41.1	41.0	—	40.2	77.6	134.8	90.4	95.5	100.8	103.4	67.9
48	44.7	43.3	43.1	—	42.2	80.7	139.8	93.9	99.2	104.6	107.3	70.9
50	46.7	45.5	45.3	—	44.3	84.0	144.9	97.4	102.9	108.6	111.4	74.5
52	48.8	47.7	60.0	<b>63.6</b>	87.3	87.3	150.2	101.0	109.0	112.6	120.0	77.7
54	51.0	50.1	62.0	<b>66.2</b>	90.8	90.8	155.6	104.8	113.0	116.7	124.0	81.5
56	53.2	52.3	65.0	<b>68.9</b>	94.3	94.3	161.1	108.6	117.0	121.0	129.0	85.0
58	55.4	55.0	68.0	<b>71.6</b>	97.9	97.9	166.7	112.4	121.0	125.3	133.0	89.0
60	57.7	57.5	70.0	<b>74.5</b>	101.6	101.6	172.5	116.4	125.0	129.7	138.0	92.9
62	60.1	60.1	73.0	<b>77.3</b>	105.4	105.4	178.5	120.4	130.0	134.3	142.0	96.9
64	62.5	62.7	76.0	<b>80.3</b>	109.3	109.3	184.5	124.6	134.0	139.0	147.0	100.7
66	65.0	65.5	79.0	<b>83.3</b>	113.2	113.2	190.7	128.8	139.0	143.7	152.0	105.3
68	67.6	68.3	82.0	<b>86.4</b>	117.3	117.3	197.1	133.2	144.0	148.6	157.0	109.3
70	70.2	71.2	85.0	<b>89.5</b>	121.4	121.4	203.6	137.6	148.0	153.6	160.4	114.1
72	72.9	74.2	89.0	<b>92.8</b>	125.7	125.7	210.3	142.2	153.0	158.7	168.0	118.7
74	75.6	77.2	92.0	<b>96.0</b>	130.0	130.0	217.1	146.8	158.0	163.9	173.0	123.4
76	78.4	80.3	95.0	<b>99.4</b>	134.5	134.5	224.0	151.5	164.0	169.3	179.0	128.3
78	81.3	83.5	99.0	<b>102.9</b>	139.0	139.0	231.1	156.3	169.0	174.7	184.0	133.2
80	84.2	86.8	102.0	<b>106.4</b>	143.6	143.6	238.4	161.2	174.0	180.3	190.0	138.3
82	87.2	90.2	106.0	<b>110.0</b>	148.4	148.4	245.9	166.2	180.0	186.0	193.6	143.6
84	90.2	93.6	109.0	<b>113.7</b>	153.2	153.2	253.5	171.4	185.0	191.9	202.0	149.0
86	93.3	97.1	113.0	<b>117.4</b>	158.2	158.2	261.2	176.6	191.0	197.8	208.0	154.5
88	96.5	100.7	117.0	<b>121.2</b>	163.2	163.2	269.2	181.9	197.0	203.9	214.0	160.1
90	99.8	104.4	121.0	<b>125.1</b>	168.4	168.4	277.3	187.4	203.0	210.2	220.0	165.9
92	103.1	108.2	125.0	<b>129.1</b>	173.7	173.7	285.5	192.9	209.0	216.6	227.0	171.9
94	106.5	112.1	129.0	<b>133.2</b>	179.1	179.1	294.0	198.6	215.0	223.1	234.0	178.0
96	110.0	116.1	133.0	<b>137.4</b>	184.6	184.6	302.6	204.3	222.0	229.8	240.0	184.2
98	113.5	120.1	138.0	<b>141.6</b>	190.2	190.2	311.4	210.2	229.0	236.6	247.0	190.6
100	117.2	124.3	142.0	<b>146.0</b>	195.9	195.9	320.4	216.2	235.0	243.5	254.0	197.2
102	120.9	128.5	146.0	<b>150.4</b>	201.8	201.8	329.6	222.3	242.0	250.6	261.0	203.4
104	124.7	132.9	151.0	<b>154.9</b>	207.7	207.7	339.0	228.5	249.0	257.9	269.0	210.2
106	128.5	137.3	156.0	<b>159.5</b>	213.8	213.8	348.5	234.9	256.0	265.3	276.0	217.3
108	132.4	142.8	160.0	<b>164.2</b>	220.0	220.0	358.3	241.3	264.0	272.9	284.0	224.4
110	136.4	146.5	165.0	<b>169.0</b>	226.4	226.4	368.2	247.9	271.0	280.6	292.0	232.3
112	140.5	151.3	170.0	<b>173.9</b>	232.8	232.8	378.3	254.6	279.0	288.6	299.0	239.3
114	144.7	156.1	175.0	<b>178.8</b>	239.4	239.4	388.7	261.5	286.0	296.6	307.0	247.0
116	148.9	161.1	180.0	<b>183.9</b>	246.1	246.1	399.2	268.4	294.0	304.9	316.0	254.8
118	153.2	166.1	185.0	<b>189.1</b>	252.9	252.9	410.0	275.5	302.0	313.3	324.0	262.9
120	157.7	171.3	191.0	<b>194.3</b>	259.9	259.9	420.9	282.7	311.0	321.9	332.0	271.7
122	162.2	176.6	196.0	<b>199.7</b>	267.0	267.0	432.1	290.1	319.0	330.7	341.0	279.5
124	166.7	182.0	202.0	<b>205.2</b>	274.3	274.3	443.5	297.6	328.0	339.7	350.0	288.0
126	171.4	187.5	207.0	<b>210.8</b>	281.6	281.6	455.1	305.2	336.0	348.9	359.0	296.8
128	176.2	193.1	213.0	<b>216.5</b>	289.1	289.1	466.9	313.0	345.0	358.2	368.0	305.7
130	181.0	198.9	219.0	<b>222.3</b>	296.8	296.8	478.9	320.8	354.0	367.8	377.0	315.0
132	185.9	204.7	225.0	<b>228.2</b>	304.6	304.6	491.2	328.9	364.0	377.6	387.0	324.2
134	191.0	210.7	231.0	<b>234.2</b>	312.5	312.5	503.7	337.1	373.0	387.5	396.4	333.7
136	196.1	216.8	237.0	<b>240.8</b>	320.6	320.6	516.4	345.4	383.0	397.7	406.0	343.5
138	201.3	223.0	243.0	<b>246.5</b>	328.9	328.9	529.4	353.9	392.0	408.1	416.0	353.4
140	206.6	229.4	250.0	<b>252.9</b>	337.3	337.3	542.5	362.6	402.0	418.7	426.0	365.0
142	212.0	235.8	256.0	<b>259.3</b>	345.8	345.8	556.0	371.4	413.0	429.6	436.0	373.9
144	217.											

## Refrigerant Temperature Pressure Chart

°C	°F	R-12	R-134A	R-401A	R-22	R-410A	R-502	R-404A	R-507
-46	-50	15.4	18.4	18.5	6.2	5.8	0.2	0.0	0.9
-44	-48	14.6	17.7	17.7	4.8	6.9	0.7	0.8	1.7
-43	-46	13.8	17.0	17.0	3.4	8.0	1.5	1.6	2.6
-42	-44	12.9	16.2	16.0	2.0	9.2	2.3	2.5	3.5
-41	-42	11.9	15.4	15.0	0.5	10.4	3.2	3.4	4.5
-40	-40	11.0	14.5	14.5	0.5	11.7	4.1	5.5	5.5
-39	-38	10.0	13.7	13.5	1.3	13.0	5.0	6.5	6.5
-38	-36	8.9	12.8	12.5	2.2	14.4	6.0	7.5	7.6
-37	-34	7.8	11.8	11.5	3.0	15.9	7.0	8.6	8.7
-36	-32	6.7	10.8	10.6	4.0	17.3	8.1	9.7	9.9
-34	-30	5.5	9.7	9.0	4.9	18.9	9.2	10.8	11.1
-33	-28	4.3	8.6	8.3	5.9	20.5	10.3	12.0	12.4
-32	-26	3.0	7.7	7.0	6.9	22.2	11.5	13.2	13.7
-31	-24	1.6	6.2	6.0	7.9	23.9	12.7	14.5	15.0
-30	-22	0.3	4.9	4.5	9.0	25.7	14.0	15.8	16.4
-29	-20	0.6	3.6	3.5	10.1	27.5	15.3	17.1	17.8
-28	-18	1.3	2.3	2.0	11.3	29.4	16.7	18.5	19.3
-27	-16	2.1	0.8	0.5	12.5	31.4	18.1	20.0	20.9
-26	-14	2.8	0.3	0.4	13.8	33.5	19.5	21.5	22.5
-24	-12	3.7	1.1	1.4	15.1	35.6	21.0	23.0	24.1
-23	-10	4.5	1.9	2.2	16.5	37.8	22.6	24.6	25.8
-22	-8	5.4	2.8	3.1	17.9	40.0	24.2	26.3	27.6
-21	-6	6.3	3.6	3.9	19.3	42.4	25.8	28.0	29.4
-20	-4	7.2	4.5	4.8	20.8	44.8	27.5	29.8	31.3
-19	-2	8.2	5.5	5.7	22.4	47.3	29.3	31.6	33.2
-18	0	9.2	6.5	6.7	24.0	49.8	31.1	33.5	35.2
-17	2	10.2	7.5	8.0	25.6	52.5	32.9	34.8	37.3
-16	4	11.2	8.5	8.8	27.3	55.2	34.9	37.4	39.4
-14	6	12.3	9.6	9.9	29.1	58.0	36.9	39.4	41.6
-13	8	13.5	10.8	11.0	30.9	60.9	38.9	41.6	43.8
-12	10	14.6	12.0	12.2	32.8	63.9	41.0	43.7	46.2
-11	12	15.8	13.1	13.4	34.7	67.0	43.2	46.0	48.5
-10	14	17.1	14.4	14.6	36.7	70.2	45.4	48.3	51.0
-9	16	18.4	15.7	15.9	38.7	73.4	47.7	50.7	53.5
-8	18	19.7	17.0	17.2	40.9	76.8	50.0	53.1	56.1
-7	20	21.0	18.4	18.6	43.0	80.2	52.5	55.6	58.8
-6	22	22.4	19.9	20.0	45.3	83.8	54.9	58.2	61.5
-4	24	23.9	21.4	21.5	47.6	87.4	57.5	60.9	64.3
-3	26	25.4	22.9	23.0	49.9	91.2	60.1	63.6	67.2
-2	28	26.9	24.5	24.6	52.4	95.1	62.8	66.5	70.2
-1	30	28.5	26.1	26.2	54.9	99.0	65.6	69.4	73.3
0	32	30.1	27.8	27.9	57.5	103.1	68.4	72.3	76.4
1	34	31.7	29.5	29.6	60.1	107.3	71.3	75.4	79.6
2	36	33.4	31.3	31.3	62.8	111.6	74.3	78.5	82.9
3	38	35.2	33.2	33.2	65.6	116.0	77.4	81.8	86.3
4	40	36.9	35.1	35.0	68.5	120.5	80.5	85.1	89.8
6	42	38.8	37.0	37.0	71.5	125.1	83.8	88.5	93.4
7	44	40.7	39.1	39.0	74.5	129.9	87.0	91.9	97.0
8	46	42.7	41.1	41.0	77.6	134.8	90.4	95.5	100.8
9	48	44.7	43.3	43.1	80.7	139.8	93.9	99.2	104.6
10	50	46.7	45.5	45.3	84.0	144.9	97.4	102.8	108.6
11	52	48.8	47.7	60.0	87.3	150.2	101.0	109.0	112.6
12	54	51.0	50.1	62.0	90.8	155.6	104.8	113.0	116.7
13	56	53.2	52.3	65.0	94.3	161.1	108.6	117.0	121.0
14	58	55.4	55.0	68.0	97.9	166.7	112.4	121.0	125.3
16	60	57.7	57.5	70.0	101.6	172.5	116.4	125.0	129.7
17	62	60.1	60.1	73.0	105.4	178.5	120.4	130.0	134.3
18	64	62.5	62.7	76.0	109.3	184.5	124.6	134.0	139.0
19	66	65.0	65.5	79.0	113.2	190.7	128.8	139.0	143.7
20	68	67.6	68.3	82.0	117.3	197.1	133.2	144.0	148.6
21	70	70.2	71.2	85.0	121.4	203.6	137.6	148.0	153.6
22	72	72.9	74.2	89.0	125.7	210.3	142.2	153.0	158.7
23	74	75.6	77.2	92.0	130.0	217.1	146.8	158.0	163.9
24	76	78.4	80.3	95.0	134.5	224.0	151.5	164.0	169.3
26	78	81.3	83.5	99.0	139.0	231.1	156.3	169.0	174.7
27	80	84.2	86.8	102.0	143.6	238.4	161.2	174.0	180.3
28	82	87.2	90.2	106.0	148.4	245.9	166.2	180.0	186.0
29	84	90.2	93.6	109.0	153.2	253.5	171.4	185.0	191.9
30	86	93.3	97.1	113.0	158.2	261.2	176.6	191.0	197.8
31	88	96.5	100.7	117.0	163.2	269.2	181.9	197.0	203.9
32	90	99.8	104.4	121.0	168.4	277.3	187.4	203.0	210.2
33	92	103.1	108.2	125.0	173.7	285.5	192.9	209.9	216.6
34	94	106.5	112.1	129.0	179.1	294.0	198.6	215.0	223.1
36	96	110.0	116.1	133.0	184.6	302.6	204.3	222.0	229.8
37	98	113.5	120.1	138.0	190.2	311.4	210.2	229.0	236.6
38	100	117.2	124.3	142.0	195.9	320.4	216.2	235.0	243.5
39	102	120.9	128.5	146.0	201.8	329.6	222.3	242.0	250.6
40	104	124.7	132.9	151.0	207.7	339.0	228.5	249.0	257.9
41	106	128.5	137.3	156.0	213.8	348.5	234.9	256.0	265.3
42	108	132.4	142.8	160.0	220.0	358.3	241.3	264.0	272.9
43	110	136.4	146.5	165.0	226.4	368.2	247.9	271.0	280.6
44	112	140.5	151.3	170.0	232.8	378.3	254.6	279.0	288.6
46	114	144.7	156.1	175.0	239.4	388.7	261.5	286.0	296.6
47	116	148.9	161.1	180.0	246.1	399.2	268.4	294.0	304.9
48	118	153.2	166.1	185.0	252.9	410.0	275.5	302.0	313.3
49	120	157.7	171.3	191.0	259.9	420.9	282.7	311.0	321.9
50	122	162.2	176.6	196.0	267.0	432.1	290.1	319.0	330.7
51	124	166.7	182.0	202.0	274.3	443.5	297.6	328.0	339.7
52	126	171.4	187.5	207.0	281.6	455.1	305.2	336.0	348.9
53	128	176.2	193.1	213.0	289.1	466.9	312.9	345.0	358.2
54	130	181.0	198.9	219.0	296.8	478.9	320.8	354.0	367.8
56	132	185.9	204.7	225.0	304.6	491.2	328.9	364.0	377.6
57	134	191.0	210.7	231.0	312.5	503.7	337.1	373.0	387.5
58	136	196.1	216.8	237.0	320.6	516.4	345.4	383.0	397.7
59	138	201.3	223.0	243.0	328.9	529.4	353.9	392.0	408.1
60	140	206.6	229.4	250.0	337.3	542.5	362.6	402.0	418.7
61	142	212.0	235.8	256.0	345.8	556.0	371.4	413.0	429.6
62	144	217.5	242.4	263.0	354.5	569.6	380.4	423.0	440.6
63	146	223.1	249.2	269.0	363.3	583.6	389.5	434.0	451.9
64	148	228.8	256.0	277.0	372.3	597.7	398.9	444.0	462.0
66	150	234.6	263.0	283.0	381.5	612.1	408.4	449.0	473.3

## The E Class Advantage

### Are Compressor Hard Start Devices Needed?

Compressor hard start devices are a luxury item for service technicians to use in rectifying a myriad of compressor start problems. It is true that the majority of hard start device applications result from the marginal voltages delivered by electric utilities during peak demand periods. As the predominant application is air conditioning, the hard start device can serve as an insurance policy for compressor starts when voltages drop to 90% of rated line conditions. The ability to ensure a compressor start under low voltage conditions can serve to minimize the number of "nuisance" service calls and allow a service contractor to focus on true problem events.

As the air conditioning industry has expanded and diversified, numerous types and models of air conditioning units and compressors have entered the marketplace. This diverse proliferation has resulted in the need to provide a one-size-fits-all compressor start device. Investigations recently undertaken by SUPCO indicate that a start device should be closely matched to the compressor, and a one size for all approach may actually cause damage to a compressor if applied incorrectly. All SUPCO technology employs the appropriate safeguards to ensure against compressor damage due to misapplied start devices. This situation does not exist for most other start device manufacturers.

### General Function

It is pertinent to discuss the general application and function of a hard start device. A capacitor in conjunction with a switching device (typically a relay) is introduced across the start windings of a single-phase compressor. Figure 1. illustrates the typical wiring arrangement for a 2-wire and a 3-wire connection.

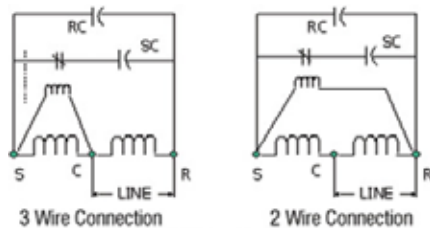

Figure 1. Wiring Configurations

When the compressor is called upon to start, the start capacitor provides a voltage boost to the start winding of the motor (effectively simulating the phasor lead/lag of a three-phase motor) and causes the motor rotor to turn. At some point, when the capacitor is released from the start winding, the motor continues to run.

*In a 3 wire configuration, the potential relay opens at a manufacturer's specified voltage across the start winding of the motor, effectively removing the start capacitor from the circuit. A third wire is necessary to connect to the run winding. In a 2 wire configuration, the potential relay and start capacitor are connected across the run and start winding. The potential relay opens at a specified increment above line voltage, thus removing the start capacitor from the circuit. There is no need for a third wire.*

The size of the capacitor significantly impacts the characteristics of the start winding. Figure 2. shows the generalized impedances for the compressor motor and start devices. As such, the start capacitor should be carefully matched to the specific compressor.

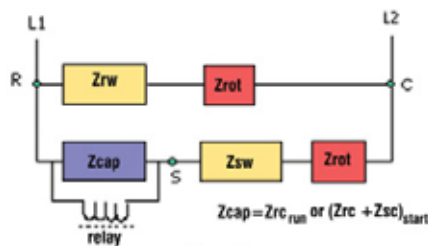

Figure 2. 2 Wire Potential Relay Equivalent Circuit

### Hard Start Technology

Two main types of start devices exist in the marketplace today. SUPCO has developed a full range of products in both types to provide a customer with all applicable choices. Both types have their own desirable applications and each have specific advantages. The two types of start devices discussed below are

1. PTC – Positive Temperature Coefficient devices
2. Potential Relay devices – voltage sensing and current sensing

### PTC Devices

The PTC device has been successfully employed in a number of applications for many years. SUPCO models SPP, SPP5, SPP6, SPP7S employ PTC technology to ensure that the start capacitor has dropped from the start circuit after an appropriate amount of time has elapsed. This device utilizes a ceramic element with a predictable thermal response to the introduction of electric current. As current is introduced across the start windings, the PTC element begins to warm. When the PTC device reaches approximately 250° F (corresponding to 0.6-0.8 seconds), the resistance in the element increases and creates an open switch that releases the start winding from the circuit. The 0.6-0.8 seconds that the PTC device allows the start windings to be engaged is generally enough time to enable the compressor to start. The advantage of this device is its simplicity. A two-wire connection between the run and start terminals on the compressor is all that is required to provide reliable starts in most cases.

However, this device has several limitations that should be considered if the application is critical.

- The PTC device has no ability to sense whether the compressor has actually started.
- The amount of time provided for a start boost is dictated solely by the temperature of the ceramic device, which has warmed due to the introduction of the starting current.
- If the compressor does not start before the temperature threshold has been reached, it will not start until the PTC device cycles through a cool-down period (usually 2 - 3 minutes). Many view this start approach as an appropriate safety measure. The PTC effectively limits the continued unsuccessful cycling of the start windings that can often result in a motor burnout. Others will argue that a start device should be able to re-cycle immediately. If this feature is desired, a PTC is not the correct start device application.

### Potential Relay Devices

The Potential Relay start device has recently been the subject of considerable attention in the market place. Several manufacturers are promoting products with a variety of technologies. The primary distinction between the potential relay devices relates to a voltage sensing or current sensing capability.

The voltage sensing method monitors start winding developed voltage and actuates a mechanical or electronic potential relay to disengage the start capacitor. The electronic potential relay is inherently more reliable and precise than the older type mechanical potential relay. SUPCO employs voltage sensing technology with an electronic potential relay.

The current sensing approach senses current through the run winding and drops the start capacitor out of the circuit based upon a threshold value. Both methods have proven effective in providing devices that are able to "sense" when a compressor has started and thus providing more reliable compressor starts in marginal conditions. However, the current sensing method must employ an internal fuse to protect the motor from potential damage and is more difficult to connect than the 2-wire voltage sensing approach.

### Capacitor Size

The proliferation of potential relay type devices has resulted in the notion that one capacitor can be employed to start all compressors. That is, use the biggest capacitor and give the compressor a "big kick" to get it started. The sensing characteristic will drop the capacitor out of the start circuit when necessary and thus the compressor will not be harmed. This idea, however, is flawed. The use of a capacitor that is too large for the impedance characteristics of the windings in some compressors can actually result in significant compressor damage. Recent investigations indicate that this situation is particularly evident in voltage sensing devices.

Figure 3. shows a successful compressor start. The run-start and start-common voltages increase to a maximum value and the total supply current drops to operating conditions when the start device is dropped from the circuit. While Figure 4. shows an unsuccessful (locked rotor) compressor start. In this figure, the run-start voltage never increases to a point indicating motor start. The total supply current remains at a maximum and the motor never starts.

Figure 3. Good Start

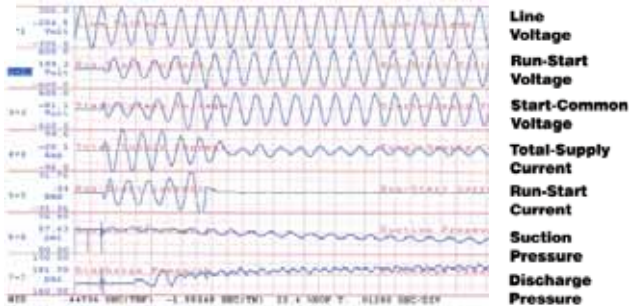
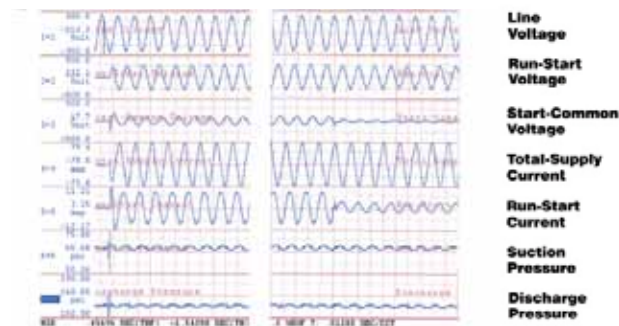
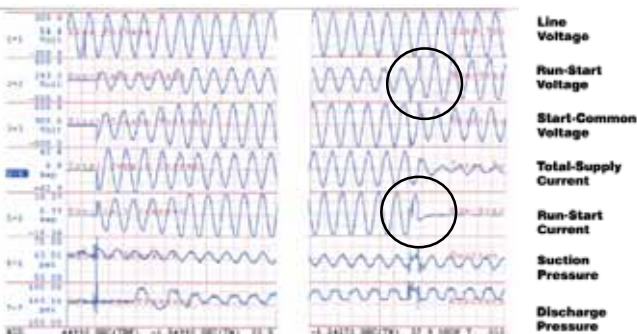

Figure 4. No Start



If the start capacitor is too large for the application, the capacitor can actually mask the developed voltage in the start windings and keep the start capacitor in the circuit continuously. Figure 5. illustrates a compressor start with a capacitor that is too large. The motor is actually running, but the run-start voltage is suppressed below the trigger voltage of the start device. As a result, the start capacitor remains in the circuit as the motor runs. A secondary, fail-safe method is necessary to ensure that the start device is ultimately removed from the circuit. This event can be seen at the end of the time duration of the run-start current highlighted in Figure 5.

Figure 5. Start with Oversized Capacitor with Safety Timing Circuit



A start device that fails to remove the start capacitor from the circuit has the potential to cause premature failure of the start windings in the compressor.

Figure 6 shows the same compressor start using an oversized capacitor without a safety timing circuit. The run-start voltage is suppressed by the combined characteristics of the motor windings and the extra large capacitor. It never reaches the prescribed threshold voltage defined by the start relay for removing the start capacitor from the circuit. The total supply current remains near the locked rotor value even after the motor has started (as highlighted in Figure 6).

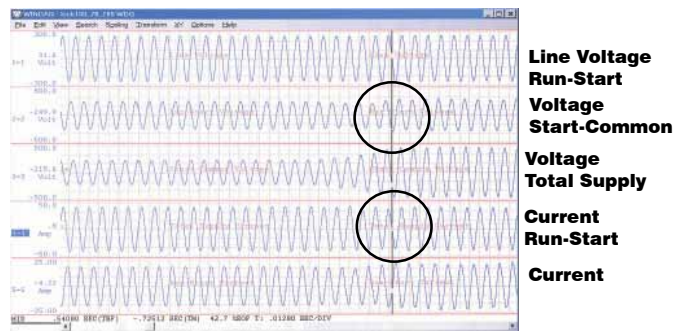

Figure 6. Start with Oversized Capacitor with out Safety Timing Circuit

If the capacitor is never removed from the start windings, premature winding failure could occur. As such, care should be taken when selecting capacitor sizes for an application. Care should also be taken regarding products that tout a “bigger capacitor is better” approach to compressor starting. SUPCO E-Class devices provide a secondary timing safety device to ensure that the start capacitor is dropped from the circuit in a fail-safe mode. Figure 5. also shows that the start winding voltage drops appropriately after the start capacitor has been removed in a SUPCO E-Class device.

### The E Class Advantage

Compressor start devices are available in a variety of forms. Specific applications call for specific products. SUPCO is one of very few manufacturers in the marketplace who provide a complete line of start devices to fit any application. PTC devices fulfill and will continue to fulfill specific needs in the industry. Potential relay devices can be found in a wide assortment. Care should be employed in selecting potential relay devices to ensure that all state-of-the-art developments are included in the product. The SUPCO E-Class Series comprise the most advanced developments in start device technology:

1. Voltage sensing technology that monitors for motor start (current sensing devices require internal fuse protection).
2. A 2-wire connection that simplifies installation
3. A secondary timing circuit that ensures that the capacitor is not permanently left in the start winding circuit
4. A fully electronic device – minimizing the limitations of mechanical devices and secondary fusing associated with triac devices
5. A start device matched with an appropriately sized capacitor to cover the range of compressors for the intended application (one size does not fit all)

The use of compressor start devices results from a need to ensure that a compressor (usually air conditioning) will start under voltage conditions that are less than ideal. As discussed, several options exist in the market to address compressor start concerns. Start devices exist in many forms for specific applications. SUPCO provides a full range of products in all relevant technologies to effectively match the proper start device to the application. Care should be taken to utilize a device that meets the requirements of the job. Extra caution should be observed when employing the “one-size-fits-all” and “a bigger capacitor is better” approach to applying a start device. Consult SUPCO, a manufacturer with a complete product range, to ensure the greatest success in the start device application.

## SUPCO HT Series Cross Reference to Potential Relay & Start Capacitor Combinations

110/220/330 V Capacitor	(88/106) & (108/130) $\mu$ F	(124/149) & (130/157) $\mu$ F	(145/175), (161/193), (189/227) $\mu$ F	(216/259) & (270/324) $\mu$ F
<b>Mars Potential Relay &amp; Start Cap</b>	<b>SUPCO</b>	<b>SUPCO</b>	<b>SUPCO</b>	<b>SUPCO</b>
63	HT70	HT80	HT80	HT100
64	HT70	HT70	HT80	HT100
65	HT70	HT70	HT80	HT100
66	HT70	HT70	HT80	HT100
67	HT70	HT70	HT80	HT100
68	HT70	HT70	HT80	HT100
69	HT70	HT70	HT80	HT100
70	HT70	HT70	HT80	HT100
71	HT70	HT70	HT80	HT100
<b>Copeland Potential Relay &amp; Start Cap</b>	<b>SUPCO</b>	<b>SUPCO</b>	<b>SUPCO</b>	<b>SUPCO</b>
040-0001-00	HT70	HT70	HT80	HT100
040-0001-01	HT70	HT70	HT80	HT100
040-0001-03	HT70	HT70	HT80	HT100
040-0001-04	HT70	HT70	HT80	HT100
040-0001-05/940-0001-71	HT70	HT70	HT80	HT100
040-0001-08	HT70	HT70	HT80	HT100
040-0001-09	HT70	HT70	HT80	HT100
040-0001-10/940-0001-72	HT70	HT70	HT80	HT100
040-0001-11/040-0001-51	HT70	HT70	HT80	HT100
040-0001-12/040-0001-64	HT70	HT70	HT80	HT100
040-0001-17/040-0001-53	HT70	HT70	HT80	HT100
040-0001-18/040-0001-63	HT70	HT70	HT80	HT100
040-0001-19/040-0001-54	HT70	HT70	HT80	HT100
040-0001-20/040-0001-55	HT70	HT70	HT80	HT100
040-0001-22/940-0001-75	HT70	HT70	HT80	HT100
040-0001-23/940-0001-76	HT70	HT70	HT80	HT100
040-0001-24/940-0001-77	HT70	HT70	HT80	HT100
040-0001-25	HT70	HT70	HT80	HT100
040-0001-27/940-0001-78	HT70	HT70	HT80	HT100
040-0001-30	HT70	HT70	HT80	HT100
040-0001-31/040-0001-52	HT70	HT70	HT80	HT100
040-0001-34/040-0001-68	HT70	HT70	HT80	HT100
040-0001-35/040-0001-59	HT70	HT70	HT80	HT100
040-0001-36/040-0001-58	HT70	HT70	HT80	HT100
040-0001-37/040-0001-70	HT70	HT70	HT80	HT100
040-0001-38/040-0001-60	HT70	HT70	HT80	HT100
040-0001-41/040-0001-80	HT70	HT70	HT80	HT100
040-0001-43/940-0001-84	HT70	HT70	HT80	HT100
040-0001-46/940-0001-85	HT70	HT70	HT80	HT100
040-0001-48/940-0001-48	HT70	HT70	HT80	HT100
040-0001-49/940-0001-49	HT70	HT70	HT80	HT100
040-0001-50/940-0001-50	HT70	HT70	HT80	HT100
040-0001-51/940-0001-51	HT70	HT70	HT80	HT100
040-0001-52/9400001-52	HT70	HT70	HT80	HT100
040-0001-53/940-0001-53	HT70	HT70	HT80	HT100
040-0001-54/940-0001-54	HT70	HT70	HT80	HT100
040-0001-55/940-0001-55	HT70	HT70	HT80	HT100
040-0001-56/940-0001-56	HT70	HT70	HT80	HT100
040-0001-57/940-0001-57	HT70	HT70	HT80	HT100
040-0001-59/940-0001-59	HT70	HT70	HT80	HT100
040-0001-60/940-0001-60	HT70	HT70	HT80	HT100
040-0001-61/940-0001-61	HT70	HT70	HT80	HT100
040-0001-62/940-0001-62	HT70	HT70	HT80	HT100
040-0001-63/940-0001-63	HT70	HT70	HT80	HT100
040-0001-64/940-0001-64	HT70	HT70	HT80	HT100
040-0001-65/940-0001-65	HT70	HT70	HT80	HT100
040-0001-66/940-0001-66	HT70	HT70	HT80	HT100
040-0001-67/940-0001-67	HT70	HT70	HT80	HT100
040-0001-68/940-0001-68	HT70	HT70	HT80	HT100
040-0001-69/940-0001-69	HT70	HT70	HT80	HT100
040-0001-70	HT70	HT70	HT80	HT100
040-0001-71/940-0001-71	HT70	HT70	HT80	HT100
040-0001-72	HT70	HT70	HT80	HT100
040-0001-73	HT70	HT70	HT80	HT100
040-0001-74	HT70	HT70	HT80	HT100
040-0001-75/940-0001-75	HT70	HT70	HT80	HT100
040-0001-76	HT70	HT70	HT80	HT100
040-0001-77	HT70	HT70	HT80	HT100
040-0001-78	HT70	HT70	HT80	HT100
040-0001-79/940-0001-79	HT70	HT70	HT80	HT100
040-0001-80/940-0001-80	HT70	HT70	HT80	HT100
040-0001-82	HT70	HT70	HT80	HT100
040-0001-83	HT70	HT70	HT80	HT100
040-0001-84	HT70	HT70	HT80	HT100
040-0001-85	HT70	HT70	HT80	HT100

## SUPCO HT Series Cross Reference to Potential Relay & Start Capacitor Combinations

110/220/330 V Capacitor	(88/106) & (108/130) $\mu$ F	(124/149) & (130/157) $\mu$ F	(145/175), (161/193), (189/227) $\mu$ F	(216/259) & (270/324) $\mu$ F
<b>Copeland Potential Relay &amp; Start Cap</b>	<b>SUPCO</b>	<b>SUPCO</b>	<b>SUPCO</b>	<b>SUPCO</b>
040-0001-85	HT70	HT80	HT80	HT100
040-0001-86	HT70	HT70	HT80	HT100
040-0001-87	HT70	HT70	HT80	HT100
040-0001-88	HT70	HT70	HT80	HT100
040-0001-89	HT70	HT70	HT80	HT100
040-0007-00	HT70	HT70	HT80	HT100
040-0007-02	HT70	HT70	HT80	HT100
040-0007-04/940-0007-04	HT70	HT70	HT80	HT100
040-0046-00/940-0046-18	HT70	HT70	HT80	HT100
040-0046-01/940-0046-19	HT70	HT70	HT80	HT100
040-0046-02	HT70	HT70	HT80	HT100
040-0046-05/999-9999-99	HT70	HT70	HT80	HT100
040-0046-07	HT70	HT70	HT80	HT100
040-0046-08/940-0046-20	HT70	HT70	HT80	HT100
040-0046-09/940-0046-21	HT70	HT70	HT80	HT100
040-0046-10/940-0046-10	HT70	HT70	HT80	HT100
<b>Tecumseh Potential Relay &amp; Start Cap</b>	<b>SUPCO</b>	<b>SUPCO</b>	<b>SUPCO</b>	<b>SUPCO</b>
P82960	HT70	HT80	HT80	HT100
P82961	HT70	HT70	HT80	HT100
P82962	HT70	HT70	HT80	HT100
P82963	HT70	HT70	HT80	HT100
P82964	HT70	HT70	HT80	HT100
P82965	HT70	HT70	HT80	HT100
P82966	HT70	HT70	HT80	HT100
P82967	HT70	HT70	HT80	HT100
P82968	HT70	HT70	HT80	HT100
P82969	HT70	HT70	HT80	HT100
P82970	HT70	HT70	HT80	HT100
P82972	HT70	HT70	HT80	HT100
P82973	HT70	HT70	HT80	HT100
<b>Bristol Potential Relay &amp; Start Cap</b>	<b>SUPCO</b>	<b>SUPCO</b>	<b>SUPCO</b>	<b>SUPCO</b>
650058	HT70	HT70	HT80	HT100
650097	HT70	HT70	HT80	HT100
650143	HT70	HT70	HT80	HT100
650153	HT70	HT70	HT80	HT100
650155	HT70	HT70	HT80	HT100
650160	HT70	HT70	HT80	HT100
650169	HT70	HT70	HT80	HT100
350304	HT70	HT70	HT80	HT100
650409	HT70	HT70	HT80	HT100
650410	HT70	HT70	HT80	HT100
650512	HT70	HT70	HT80	HT100
650567	HT70	HT70	HT80	HT100
650568	HT70	HT70	HT80	HT100
650569	HT70	HT70	HT80	HT100
650570	HT70	HT70	HT80	HT100
650571	HT70	HT70	HT80	HT100
650855	HT70	HT70	HT80	HT100
650879	HT70	HT70	HT80	HT100
650887	HT70	HT70	HT80	HT100
650889	HT70	HT70	HT80	HT100
650919	HT70	HT70	HT80	HT100
650926	HT70	HT70	HT80	HT100
650929	HT70	HT70	HT80	HT100
650942	HT70	HT70	HT80	HT100
950943	HT70	HT70	HT80	HT100
650944	HT70	HT70	HT80	HT100
650945	HT70	HT70	HT80	HT100
650946	HT70	HT70	HT80	HT100
650947	HT70	HT70	HT80	HT100
650948	HT70	HT70	HT80	HT100
650949	HT70	HT70	HT80	HT100
650950	HT70	HT70	HT80	HT100
650951	HT70	HT70	HT80	HT100
650959	HT70	HT70	HT80	HT100
650962	HT70	HT70	HT80	HT100
650965	HT70	HT70	HT80	HT100
650968	HT70	HT70	HT80	HT100
650971	HT70	HT70	HT80	HT100
650972	HT70	HT70	HT80	HT100
650975	HT70	HT70	HT80	HT100
650976	HT70	HT70	HT80	HT100
650977	HT70	HT70	HT80	HT100
650978	HT70	HT70	HT80	HT100
650979	HT70	HT70	HT80	HT100

## SUPCO HT Series Cross Reference to Potential Relay & Start Capacitor Combinations

110/220/330 V Capacitor	(88/106) & (108/130) $\mu$ F	(124/149) & (130/157) $\mu$ F	(145/175), (161/193), (189/227) $\mu$ F	(216/259) & (270/324) $\mu$ F
<b>White Rodgers/RBM Potential Relay &amp; Start Cap Cross Reference To Supco</b>				
90-1	HT70	HT80	HT80	HT100
90-2	HT70	HT80	HT80	HT100
90-3	HT70	HT80	HT80	HT100
90-4	HT70	HT80	HT80	HT100
90-5	HT70	HT80	HT80	HT100
90-6	HT70	HT80	HT80	HT100
90-7	HT70	HT80	HT80	HT100
90-8	HT70	HT80	HT80	HT100
90-9	HT70	HT80	HT80	HT100
90-10	HT70	HT80	HT80	HT100
90-11	HT70	HT80	HT80	HT100
90-12	HT70	HT80	HT80	HT100
90-13	HT70	HT80	HT80	HT100
90-14	HT70	HT80	HT80	HT100
90-15	HT70	HT80	HT80	HT100
90-16	HT70	HT80	HT80	HT100
90-17	HT70	HT80	HT80	HT100
90-18	HT70	HT80	HT80	HT100
90-19	HT70	HT80	HT80	HT100
90-20	HT70	HT80	HT80	HT100
90-21	HT70	HT80	HT80	HT100
90-22	HT70	HT80	HT80	HT100
90-23	HT70	HT80	HT80	HT100
90-24	HT70	HT80	HT80	HT100
90-25	HT70	HT80	HT80	HT100
90-26	HT70	HT80	HT80	HT100
90-27	HT70	HT80	HT80	HT100
90-40	HT70	HT80	HT80	HT100
90-41	HT70	HT80	HT80	HT100
90-63	HT70	HT80	HT80	HT100
90-64	HT70	HT80	HT80	HT100
90-65	HT70	HT80	HT80	HT100
90-66	HT70	HT80	HT80	HT100
90-67	HT70	HT80	HT80	HT100
90-68	HT70	HT80	HT80	HT100
90-69	HT70	HT80	HT80	HT100

### SUPCO To OEM Cross Reference

SUPCO	Kickstart	Coleman/Fraser Johnson/Luxaire/Source One		
HT70	KS8	024-32005-000		
HT80	T05	024-31994-000		
HT90	MP1	N/A		
HT100	KS1	024-31995-000		
SUPCO	Intercity Products	Maneurop/Danfoss	Rheem/Ruud	
HT70	N/A	N/A	42KS8	
HT80	1160725	N/A	42-102004-02-00	
HT90	N/A	7305543	N/A	
HT100	N/A	N/A	42-102004-01-00	
SUPCO	Trane	Whirlpool	York	
HT70	N/A	8088840	N/A	
HT80	CPT00697	8088838	161485	
HT90	N/A	N/A	N/A	
HT100	KIT2786	8088839	N/A	
SUPCO	Goodman	Lennox		
HT70	N/A	N/A		
HT80	T05	89P36		
HT90	N/A	N/A		
HT100	KS1	77N48		

### SUPCO To Wholesale Cross Reference

SUPCO	Kickstart	Barsco	Fidelitone	
HT70	KS8	N/A	N/A	
HT80	T05	3370020	96--T0-5P	
HT90	MP1	N/A	N/A	
HT100	KS1	33770010	N/A	
SUPCO	Insco	Johnson Supply	Johnstone	
HT70	4680110	N/A	B13-545	
HT80	4680500	509950	B11-947	
HT90	N/A	N/A	B12-856	
HT100	4680098	509710	B12-855	
SUPCO	Protech			
HT70	42-KS8			
HT80	42-T05			
HT90	N/A			
HT100	42-KS1			

# SCM/SCMPLUS - Surge Protector Installation, Warranty & Connected Equipment Guarantee Information

## INSTALLATION INSTRUCTIONS:

\*Note: The SCMPLUS uses an LED diagnostics connected at each phase wire to indicate power, ground and surge protection activity.  
LED Sequence

1 LED = 120 VAC L-G operation

2 LED = 240 VAC L-L operation

**These devices do not protect electronic appliances such as TV's, computers, microwaves, etc. They only protect dedicated electromechanical devices such as air conditioners. If whole house protection is required use SUPCO p/n DTK-WH5. Which will protect AC power, coaxial and two telephone lines.**

## WIRING DIAGRAM:

These devices include two black wires and one green wire. A surge protector works by shunting the voltage surge to ground. A good ground is imperative. The National Electric Code (NEC) maximum resistance at ground is 25 ohms.

240 Volt Wiring	120 Volt Wiring
Black to Hot	Black to Hot
Black to Hot	Black to Neutral
Green to Ground	Green to Ground

A/C Disconnect Installation (For HVAC Applications): (Fig. 1)

Although the SCM or SCMPLUS can be installed at the main breaker panel, SUPCO recommends installation at the service disconnect for the A/C condenser. The surge arrester is a simple three (3) wire installation that should take no more than 5 minutes to complete.

1. Turn off the main power to the service disconnect and meter test for safety.
2. Remove a knockout from the disconnect.
3. Remove the retaining ring from the nipple on the SCM or SCM PLUS.
4. Feed the nipple and wire into the service disconnect.
5. Re-secure with the retaining ring.
6. Route the green wire to the Grounding lug and secure.
7. Securely 'Piggyback' them

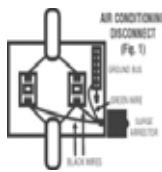

Once power is restored the green LED will light (SCM PLUS Only) to indicate SURGE PROTECTION PRESENT.

Electrical Panel Installation: (Fig. 2)

1. Turn off main breaker
2. Remove the front cover from the panel.
3. Remove 3/4" knockout on side of panel box.
4. Mount unit through the knockout to the side of the panel.
5. Secure green wire to the grounding bus.
6. Connect the black wires to the load side of the closest two pole breaker.
7. Connected wiring must be kept short.
8. Replace front cover of panel box.

## INSTALLATION TIPS:

1. Never sharply bend the surge arrester wires during termination. Offer the surge as straight a pathway to ground as possible.
2. Always keep the surge arrester wires as short as possible to increase the effectiveness and response time of the unit.
3. Always keep the protector at least 3 ft. from the equipment that you want to protect. This allows response time for the protector to do its job before the transient gets to the protected equipment.

FOR FURTHER INFORMATION  
CONTACT TECHNICAL SUP-

PORT AT  
1-800-333-9125

Electrical Panel  
(Fig. 2)

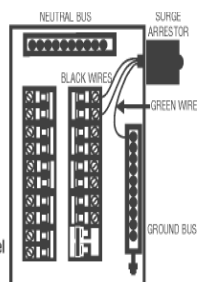

## LIMITED LIFETIME WARRANTY FOR STANDARD INDOOR RESIDENTIAL AND COMMERCIAL SURGE PROTECTORS

Thank you for choosing a SUPCO surge protection product to protect your equipment. You will be pleased to know that SUPCO surge arrestors will prove you with years of security and protection.

LIMITED LIFETIME WARRANTY AGAINST MANUFACTURING DEFECTS; SUPCO warrants these surge arrestors to be free of all defects in workmanship or material for the lifetime of the original purchaser, and that SUPCO will repair or replace any defective unit. Warranty registration must be filled out complete and mailed to SUPCO within 15 days of installation.

SUPCO surge arrestors are designed to dissipate the damaging effects of momentary voltage spikes or other transient power surges including impulses from lightning. They are not warranted against direct lightning, continuous over voltage, over current nor dropped neutrals.

Proper Installation:

SUPCO AC surge arrestors must be connected in accordance with SUPCO's installation instructions. Building wiring must conform to National Electric Code or Canadian Electric Code. All wires leading into the protected equipment must pass through a single SUPCO surge arrester.

## CONNECTED EQUIPMENT GUARANTEE SUPCO SCM & SCMPLUS

Connected Equipment Guarantee:

SUPCO will replace or pay to repair, up to \$500 per occurrence\* with a lifetime cap of \$10,000, any electromechanical or motor-driven appliance that is damaged by a voltage surge passing through the surge protector to the equipment. The SUPCO Surge Protector must show signs of surge damage or be operating outside of design specifications. In order to be eligible for this connected equipment coverage the surge protector must be installed in the immediate vicinity of the equipment being protected. For instance, an A/C compressor unit must be protected inside the compressor box or no further away than the disconnect. The inside air handler may be protected at the nearest panel box but inside the same building.

**Period of coverage: 3 years from date of installation.**

**\* \$500 per occurrence for the SCM.**

**\* \$1000 per occurrence for the SCMPLUS.**

Claim Procedure:

If you want to make a claim you must first contact customer service at 1-800-333-9125 for a return authorization number to return the defective surge protector. You must notify SUPCO at this time if you believe you have a connected equipment claim. SUPCO will send you an information packet to be completed and returned within 20 days. SUPCO reserves the right to inspect the damaged equipment. Once SUPCO has determined that you are entitled to compensation for your claim, SUPCO will at its option, pay the present fair market value of the damaged equipment, send you replacement equipment or pay for the cost of the repair. All of the foregoing is subject to a cap of \$500.00 per occurrence for the SCM and \$1000.00 per occurrence for the SCMPLUS, with a lifetime cap of \$10,000 for both.

## Commercial Refrigeration Condensate Evaporator Pans Cross Reference

SUPCO NO.	FISHER EVAPOWAY P/N	BIRMINGHAM
CP801	DM04T-1S	840111
CP804	DM10M-S1	810134
CP804-240	DM10M-3S	***
CP802	DM08S-1S	880111
CP804HD	DM10W-1D	810114
CP804HD-240	DM10W-3D	***
CP807	DM10W-1S	***
CP815	DM15WW-1D	815134
CP807-240	DM10W-3	810244
CP815-240	DM15WW-3	815244
CP816	DM05W1D	850114
CP817	DM10W2D	810214
CP818	DM10W2S	***
CP819	DM15W1D	815114
CP820	DM15W2D	815214
CP821	DM15WW2D	815234

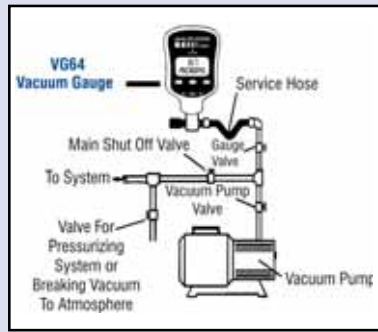

### Application Note: CONNECTING THE VG64 TO THE VACUUM SYSTEM

A vacuum gauge should be connected to the vacuum system at the vacuum port. The "Auxiliary Port" is primarily for cleaning and should normally be closed with the supplied cap. It is possible to connect the vacuum gauge in-line, however, it may restrict flow and increase the evacuation time.

### CHECKING HVAC SYSTEMS FOR LEAKS

When checking a system for leaks use only copper tubing and a vacuum proof valve. Generally, standard hoses will not hold a vacuum. If using the blank-off valve on the vacuum pump check it for leaks periodically. At the beginning of the test the vacuum gauge reading may increase due to a system equalization. The vacuum reading should hold after a minimum of 5 minutes. If the reading continues to increase it may indicate a leak in the system.

## Commercial Defrost Control Wiring Diagrams

### Wiring Diagrams Electric Heat Defrosting S8041 & S8045 Series

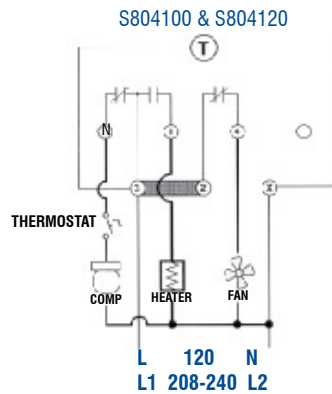

Fan and compressor loads not to exceed 2 hp. Heater not to exceed 4000 watts at 120V AC or 8000 watts at 240V AC.

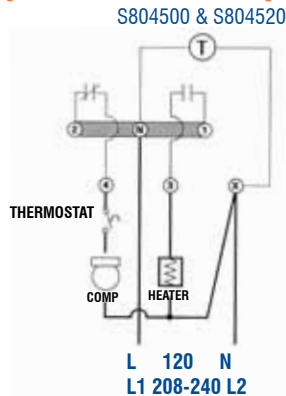

Heater not to exceed 4000 watts at 120V AC or 8000 watts at 240V AC.

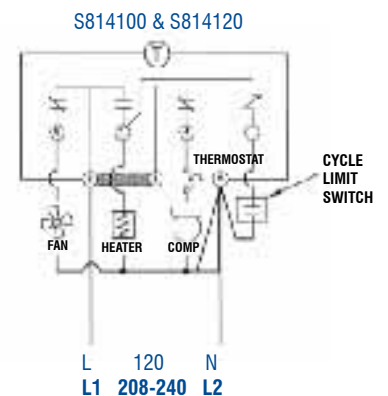

Wiring using 120V or 240V single phase line with auxiliary fan circuit.

### Wiring Diagrams Electric Heat Defrosting S8141 & S8145 Series

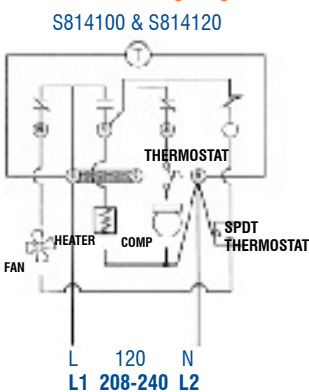

Wiring using differential of SPDT thermostat to delay fan after defrosting.

### Wiring Diagrams Electric Heat Defrosting S814500 & S814520

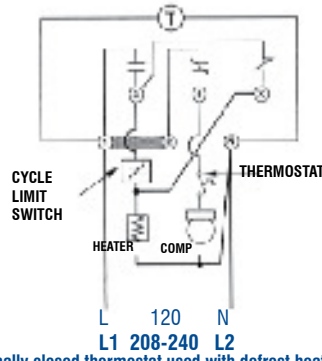

Normally closed thermostat used with defrost heater. Wiring using 120V or 240V single phase line compressor voltage common to timer.

### Wiring Diagrams Hot Gas Defrosting S8145 Series S814500 & S814520

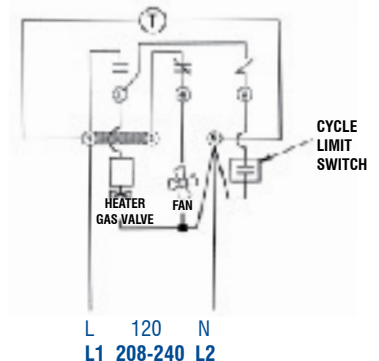

Wiring using 120V or 240V single phase line compressor thermostat closed during defrost.